



**CRANES - SHOVELS  
DRAGLINES**



**NON-ASBESTOS  
INDUSTRIAL  
FRICTION  
MATERIALS**



# FRICITION MATERIAL

## SELECTION GUIDE

There are three types of Industrial Friction Materials. Scan-Pac manufactures all three.

They are:

- Rigid Molded (RF products)
- Flexible Woven Linings
- Semi-flexible and Rigid Sheeter Type Linings

The selection of the proper product for an application depends upon the severity or duty requirements. Severity or duty are based upon the amount of heat that will logically be generated in use. As duty changes from light to medium to heavy, the temperatures increase.

Examples of **heavy duty applications** and equipment include: high speed dynamic braking equipment; tensioning brakes; overhead crane brakes; swing clutches, hoist and drag brakes on drag-lines, cranes, and shovels; winches, hoists, punch press clutches and brakes; and gear tooth facings.

Scan-Pac RF (rigid molded) products are the top recommendation for heavy duty service.

**Medium duty applications**, expected to operate at somewhat reduced temperatures, include; intermittent operating clutches of all types; holding brakes; overload clutches; mooring winches; elevator brakes, and small punch press brakes and clutches.

In the medium and light duty category, any of the product types can be used.

Rigid molded (RF) materials exhibit the longest life and highest temperature capabilities. But when used where worn drums or other mechanical problems exist, they take a longer period of time to “seat” or wear in. When wear in time is a major consideration flexible molded or woven products can be substituted with some sacrifice in life and wear resistance.

When equipment has a full-wrap flexible brake band or in the case of a heavy duty application where the use of a number of rigid molded segments is not possible or desirable, flexible molded or woven products are acceptable.

FEATURE	RIGID MOLDED	WOVEN ROLL	MOLDED ROLL
Range of Friction Available	E	A	A
Lining Life	E	G	G
Drum Wear	E	G	G
Use on Worn Drum	F(1)	G	G
Use on Scored Drum	G	E	G
High Temperature Fade	E	A	G
Oil - Intermittent	G - E(2)	G	A - E(2)
Oil - Immersed	A - E(2)	G	A - E(2)
Ease of Inventory	A	E	E
Overall Performance	E	G	G

E - Excellent; G - Good; F - Fair; A - Adequate

NOTE (1) If proper oversize is used the performance will be “E.”

NOTE (2) Performance dependent on product used. For proper material recommendation, the presence of or immersion in oil must be indicated.

# FRICTION MATERIAL LOCATION GUIDE

To properly identify the type of friction used on various bands and clutches, it is necessary to understand the function each performs. The basic mechanism in all cabs is the same regardless of the type of boom used. The driving power may be gas, diesel, electric or steam. Brakes may be internal expanding or external contracting. Clutches may be band type or facing. In most cases they are known by the duty they perform. A band type clutch is known as the "friction"; the brake as the "brake".

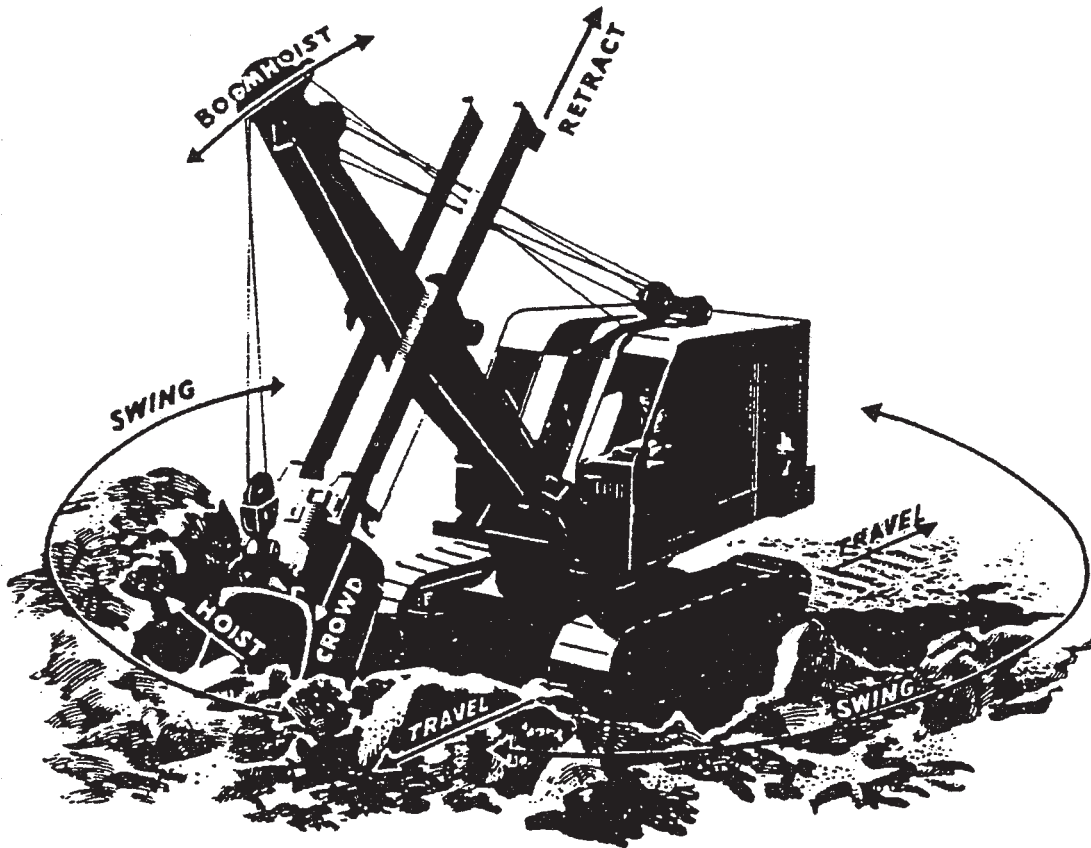

## SWING FRICTIONS:

These frictions, often called swing clutches, are used to rotate the super-structure of shovels; cranes and draglines to any desired working position. They may be of the external contracting or internal expanding band type; internal expanding self-energizing shoe type; single or double cone construction; or disc type. Since the digging cycle of all modern machines has been materially speeded up, resulting in severe usage, swing frictions are relined more frequently than other frictions on a machine.

## SWING BRAKE:

The application of brakes to hold super-structures in position has never been very successful except on light equipment. On some of the smaller machines, automatic brakes have proved to be fairly successful. In most operations when swinging to right or left the swinging motion must be stopped by using the opposite swing friction.

## HOIST FRICTION:

The hoist friction is the large power clutch used for hoisting the bucket when digging and then lifting the

loaded bucket so that it is free to swing. The friction, either of the internal expanding or external contracting band type, may be operated by manually controlled levers or by hydraulic; air, vacuum or mechanical boosters.

## HOIST BRAKE:

The hoist brake, on the same shaft as the hoist friction, is used to hold the spooling drum and bucket in a definite position, particularly while swinging. The brake is usually an external contracting band type.

## BOOM FRICTION:

A small independent friction which is used for raising the booms to suit digging conditions. Since this friction is infrequently used, the frictional material problem is of minor importance.

## BOOM BRAKE:

In conjunction with the boom hoist friction, there is a locking brake which simply holds the hoist in position. This brake is of the external contracting band type.

## CRANE, SHOVEL AND DRAGLINE FRICTIONS

### *Table of Contents*

APPLICATION CATALOG	PAGE NO.
American Hoist & Derrick .....	2
Bucyrus Erie .....	4
Bucyrus Monighan .....	7
Koehring .....	7
Lima .....	7
Link Belt .....	8
Lorain .....	7
Manitowoc .....	10
Marion .....	11
Northwest Engineering .....	12
P & H .....	13
Page .....	15
Unit Crane .....	15
Washington .....	15

**Note:** D suffix after part number indicates drilled set.  
 KL suffix after part number indicates key locked set  
 These sets are also available plain.

FRICITION MATERIAL APPLICATIONS - INDUSTRIAL MACHINES

**AMERICAN HOIST & DERRICK**

APPLICATION	MFG.-P/N	SP-P/N	SIZE	D.D	PCS/ SET	SETS/ MACH.
<b>300 SERIES:</b> 375 BC & BT, 395 BC & BT, 397 BC, 399 BC						
Hoist & Drag Friction	137511-5	21400	3 1/2x3/8x13 1/2	21E	4	2
Or	L7801	21500D	3 1/2x7/16x3	21E	16	2
Hoist & Drag Brake	L3106	27501D	3 1/2x1/2x3 1/2	27 <sup>1</sup> / <sub>2</sub> E	20	2
Hoist Friction Booster	F4106-1	232AF Roll	2x1/4x16	8E	2	1
Boom Hoist Friction		232AF Roll	3 1/4x3/8x38 1/4	15E	1	1
Or		232AF Roll	3x3/8x34	15E	1	1
Boom Hoist Brake		232AF Roll	2 1/2x1/4x40	18E	1	1
Swing Friction	F7345	17500D	3 1/2x7/16x3 27/64	18N	12	2
Or	D8735	17400D	3 1/2x3/8x4 11/16	18N	8	2
Swing Brake		232AF Roll	2 1/2x1/4x40 3/4	15E	1	1
<b>400 SERIES:</b>						
	512938	32401D	4x1/2x4 3/4	32E	16	
Swing Friction	427676	19500D	4x1/2x5 1/4	20N	8	2
<b>500 SERIES:</b> 575, 595, 597, 599						
Hoist & Drag Friction	L6662	30500D	4x1/2x7 5/8	30E	8	2
Hoist & Drag Brake	L6832	39500D	4x1/2x5 11/16	39E	17	2
Boom Hoist Friction	132339x1-2	232AF Roll	2 1/2x1/4x22	17E	2	1
Boom Hoist Brake	L6847	23400D	2 1/2x3/8x5 11/16	23 <sup>1</sup> / <sub>2</sub> E	7	1
Swing Friction	L6664	22500D	4x1/2x4 7/6	23N	12	2
Or		22505	5x1/2x6 1/2(RF34)	23N	8	
Swing Brake	L6646	232AF Roll	2x3/8x53 5/8	21E	2	1
<b>700 SERIES:</b> 750C, 775C, 795C, 797, 799						
Hoist & Drag Friction	F5832	36500D	5x1/2x5	36E	14	2
Or	435615	35600D	5x5/8x6 3/4	36N	12	2
Hoist & Drag Brake	F5978	46500D	5x1/2x5 11/16 6D&C	46E	20	2
		46504D	5x1/2x5 11/16 4D&C	46E		
Boom Hoist Friction	474927	232AF Roll	2 1/2x1/4x22	17E	2	1
Boom Hoist Brake	64856-4	232AF Roll	2 1/2x1/4x54 1/2	23 <sup>1</sup> / <sub>2</sub> E	1	1
Swing Friction	F5805	26500D	5x1/2x5 1/4	26E	10	2
Or	408558	27500D	6x1/2x6 1/8	28N	10	2
Propel Brake	F6756	32500D	5x1/2x5	32E	16	1
Propel Friction	F6778	24500D	5x1/2x5 1/2	24E	11	1
<b>830-DE</b>						
Boom Hoist Brake		232AF	3x3/8x34	20E	2	1
Boom Hoist Friction		232AF	2 1/4x1/4x22 3/16		2	1
Hoist Brake		38500D	4x1/2x5 13/16	38E	16	1
Propel Brake		25402	7x3/8x16	25E	2	2
Swing Friction		24501D	4x1/2x7 1/2	24E	6	2
Swing Brake		232AF	2 1/4x1/4x47	25E	2	2
<b>840-DE</b>						
Hoist Friction		HOMAF	4x3/8x100		1	1
Hoist Brake	L8899	46501D	6x1/2x6 1/8	46E	19	1
Swing Friction	C6283	30501D	5x1/2x9 (RF34)	30E	6	2

**AMERICAN HOIST & DERRICK**

APPLICATION	MFG.-P/N	SP-P/N	SIZE	D.D	PCS/ SET	SETS/ MACH.
<b>900 SERIES:</b>						
Hoist & Drag Friction	444655	43600D	6x5/8x6 1/2	44N	16	1
Or	501016	44500D	6x1/2x6 1/4	44E	14	2
Hoist & Drag Brake	501779	57600D	7x5/8x8 1/4	57E	18	2
Boom Hoist Friction	L6664	22500D	5x1/2x4 7/16	23N	12	1
Boom Hoist & Brake	C4950	24501D	4x1/2x7 1/2	24E	6	1
Swing Friction	401153	35601D	8x5/8x7	36N	12	2
Ind. Swing Friction	L6664	22500D	4x1/2x4 7/16	23N	12	1
Swing Brake	527561	36400D	3x3/8x8	36E	11	
<b>4120</b>						
Hoist Brake	411172	24502D	4x1/2x5 3/4	25N	11	
<b>4210</b>						
Hoist Clutch	413575	32400D	4x1/2x4 3/4	32E	16	
Swing Friction	427676	19500D	4x1/2x5 1/4	20N	8	2
Boom Hoist Clutch	411180	15501D	3x7/16x4 1/4	16N	12	
<b>9460</b>						
Hoist & Drag Brake	511779	57600D	7x5/8x8 1/4	57E	18	2

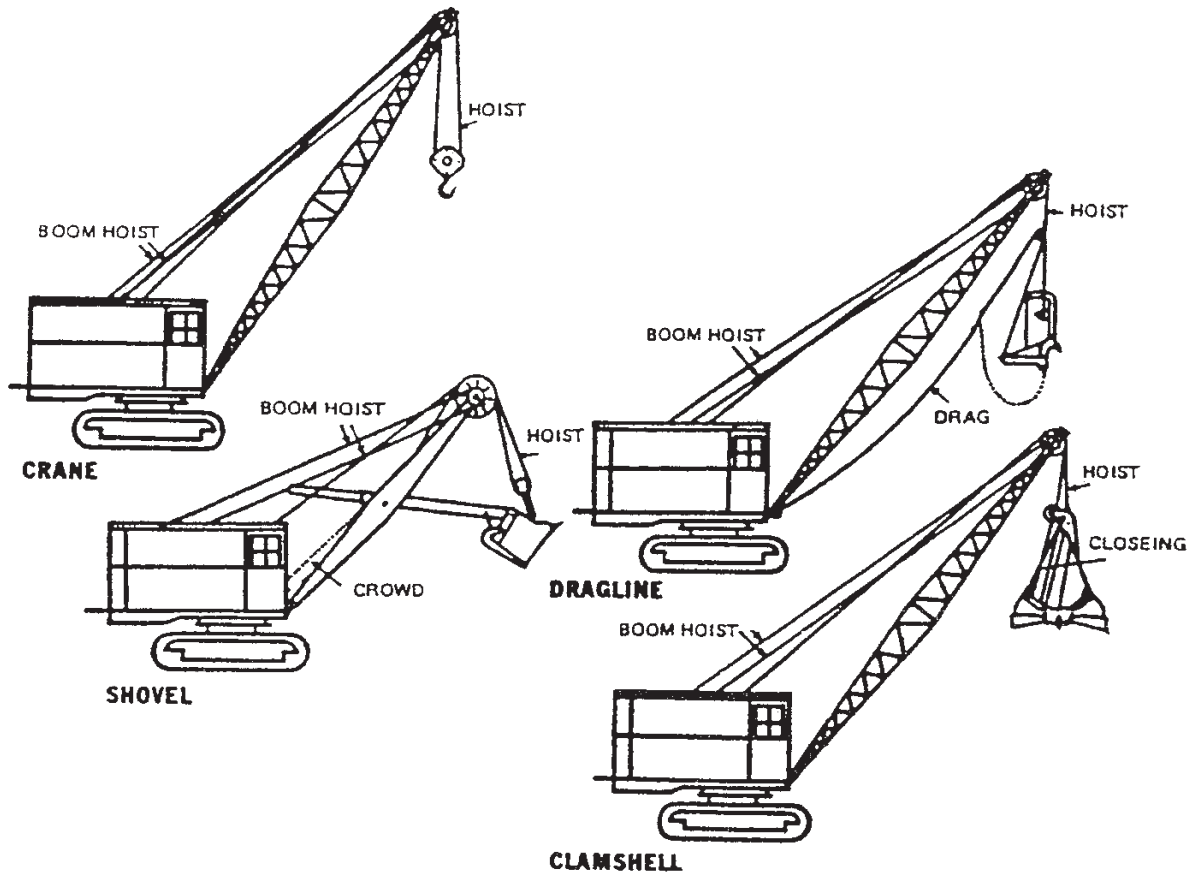



FRICION MATERIAL APPLICATIONS - INDUSTRIAL MACHINES

**BUCYRUS - ERIE**

APPLICATION	MFG.-P/N	SP-P/N	SIZE	D.D	PCS/ SET	SETS/ MACH.
<b>15B</b>						
Swing, Hoist & Crowd		19302	2 1/2x5/16x10 1/4	20N	5	5
<b>22B</b>						
Swing Hoist Crowd & Retract	506890K51	23404	3x3/8x12 1/2	24N	5	5
Or		23501	3x1/2x12 1/2	24N	6	3
Boom Hoist Brake		HDM-AF	2 1/4x1/4x15	24E	4	
Or		HDM-AF	2x1/4x26	24E	2	
Or		HDM-AF	2 1/2x1/4x14 1/2	24E	4	
Boom Hoist Friction		HDM-AF	2x1/4x12 5/16	20N	4	
Or		HDM-AF	3x1/4x9 1/4	20N	5	
Hoist & Crowd Brake	504489-K1	27401	3x3/8x10.938 (6)	27 1/2E	8	
	504492-K61		3x3/8x10.847 (1)			
	504492-K72		3x3/8x5.50 (1)			
	504490					
<b>25B</b>						
Swing Friction	524005K1	} 23500D	4x1/2x8 3/16	24N	12	2
	524006K1					
	510983K1					
	510984K51					
Hoist Brake	516230K2	24401	3x3/8x11 1/2	24E	1	1
Or	514500K1	} 26400	4x3/8x10 15/16 (6)	27 1/2E	8	
	514501K1		4x3/8x1 3/8 (1)			
	514502K1		4x3x95/8 (1)			
Propel Brake	510392K52	} 14400	3x3/8x7	14E	3	2
	510391K1					
<b>30B</b>						
Hoist & Crowd Friction	(Old) 510335K51	} 30600	4x5/8x10 9/64	31N	6	3
	555648K51					
Hoist Brake	(Old) 507989K53	} 34401	4x3/8x13 7/8	34 5/8E	6	1
	550934K51					
Or	(Kit) 533308K51	} 35401D		34 5/8E	10	2
	533308K1		5x3/8x13 7/8 (4)			
	533307K1		5x3/8x13 7/8 (2)			
	533312K1		5x3/8x13 7/8 (2)			
Or	(Old) 902908K52	} 34400	4x3/8x13 7/8 (4)	34 5/8E	5	2
	550934K61		4x3/8x5 3/16 (1)			
Or	(Old) 507989K53	} 34401	4x3/8x13 7/8	34 5/8E	6	2
	550934K51					
Hoist Brake (Early)	(Kit) 550512K51	} 26401		27 1/2E	6	
	550512		4x3/8x10 15/16 (4)			
	550514		4x3/8x10 15/16 (2)			
Or	(Kit) 550511K51	} 26400		27 1/2E	8	
	550512		4x3/8x10 15/16 (4)			
	550514		4x3/8x10 5/16 (2)			
	550510		4x3/8x9 5/16 (1)			
Independent Propel	500166K1	30401	3 1/2x3/8x11 15/16	31N	7	
Propel Brake	(Old) 509853K53	} 20401	3 1/2x3/8x10 3/16	20E	3	4
	550855K52					

**BUCYRUS - ERIE**

APPLICATION	MFG.-P/N	SP-P/N	SIZE	D.D	PCS/ SET	SETS/ MACH.
<b>38B</b>						
Ind. Propel Friction	G02113K1	19300D	4x5/16x10 1/2	20N	5	
Hoist & Crowd	(Kit) 510023K54					
	510022K4	40503D	4x1/2x11 3/16 (8)	40E	12	2
	510023K4		4x1/2x11 5/8 (2)			
	510022K5		4x1/2x4 5/16 (2)			
Or	(Kit) 510754K44	40506D				
	510022K4		4x1/2x11 3/16 (8)	40E	12	2
	510753K4		4x1/2x11 5/8 (2)			
	510022K6		4x1/2x4 9/16 (2)			
Or	518777K51	40504	5x1/2x11 5/16	40E	12	2
Or	510022K1	40401	4x3/8x11 5/16	40E	9	2
Hoist & Crowd Friction	552391	35400	4x3/8x15 1/4	36N	5	2
Or	506923K51	33400	4x3/8x15 1/4	34N	6	1
Hoist & Drag Brake	527501K1	42501D	5x1/2x12	42E	10	1
Or		42503D	5x1/2x11 7/8	42E	8	
Hoist & Drag Friction		33500D	4x1/2x16	34N	3	2
Boom Hoist Friction		HDM-AF	3x1/4x10 13/16	18N	4	1
Boom Hoist Brake	285596	22200D	3x1/4x13 1/2	22E	4	1
Or	x12041	HDM-AF	2x3/8x12	15E	2	1
Swing Friction	901364K51	23401D	6x3/8x10 3/8	24N	6	2
Retract Friction	604778K51	23402	4x3/8x10 5/16	24N	6	1
Travel Friction	901379K51	HDM-AF	4x3/8x14 3/8	20 7/8N	4	1
Swing & Retract Frictions	550910K2	23502D	6x1/2x8 3/16	24N	6	3
Cab Lock Swing Brake		F17600D	7/8x17 <sup>1</sup> / <sub>4</sub> I.D.x21 <sup>1</sup> / <sub>4</sub> O.D.	90° seg	4	1
<b>51B</b>						
Hoist Friction		37400	5x3/81x13 1/4	38N	8	2
Swing Friction	900445K51	29400D	6x3/8x11 1/4	30N	7	2
<b>548</b>						
Hoist & Crowd Friction	287291	44502D	5x1/2x9 1/8 (10)	44E	12	2
			5x1/2x9 1/8 (2)			
Hoist & Crowd Brake	282598	44501D	5x1/2x9 1/8 (11)	44E	13	2
			5x1/2x9 1/8 (2)			
Boom Hoist Friction		HDM-AF	3x1/4x10 13/16	18N	4	1
Boom Hoist Brake	285596	22200D	3x1/4x13 1/2	22E	4	1
Or	x12041	HDM-AF	2x3/8x12	15E	2	1
Swing Friction	285024	35500D	8x1/2x12 1/4	36N	8	1
Retract Friction	283503	24400	6x3/8x10 3/8	24E	6	1
<b>618</b>						
Swing Friction	520188K51	30700D	8x3/4x10 1/2	31N	6	2
Or	552651K51	30701D	8x3/4x10 1/2 (RF34)	31N	6	2
Hoist & Drag Brake	520202K51	48600	6x5/8x14 3/8	48E	8	2
Or	550133K51	48602D	6x5/8x14 3/8 (4)	46E	9	2
	550133K61		6x5/8x14 3/8 (4)			
			6x5/8x11 1/4 (1)			
<b>718</b>						
Hoist & Drag Friction	516455K4	48500D	5x1/2x9 1/4 (2)	48E	13	2
			5x1/2x9 1/4 (11)			
Hoist & Drag Brake	287291	44502D	5x1/2x9 1/8 (10)	44E	12	2
			5x1/2x9 1/8 (2)			
Swing Friction	516463-K1	35700D	8x3/4x13 1/4	36N	6	2
Or	510558	39600D	8x5/8x14 1/4	40N	6	1
Or		39600KL	8x5/8x14 1/4	40N	6	1



FRICION MATERIAL APPLICATIONS - INDUSTRIAL MACHINES

**BUCYRUS - ERIE**

APPLICATION	MFG.-P/N	SP-P/N	SIZE	D.D	PCS/ SET	SETS/ MACH.
<b>88B</b>						
Hoist & Drag Friction	548615	} 45500D	6x1/2x11 3/4 (1)	46N	10	1
	548616		6x1/2x11 3/4 (9)			
Hoist & Drag Brake	502968K1	56704D	7x3/4x11 3/4	56E	12	1
Swing Friction	510558	39600D	8x5/8x14 1/4	40N	6	2
Or		39600K	8x5/8x14 1/4	40N	6	2
Hoist & Crowd Brake		56501D	7x1/2x11 3/4	56E	12	
Or	520968K1	56600KL	7x5/8x11 3/4	56E	12	
Crowd Brake	552668-01	} 40505D	7x1/2x12 13/16	39E	8	
	552670-01					
Cab Brake	550106K1	24507	4 1/2x1/2x9 1/2	24 3/4E	2	

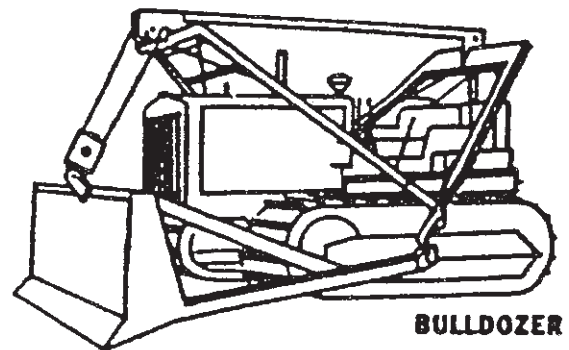
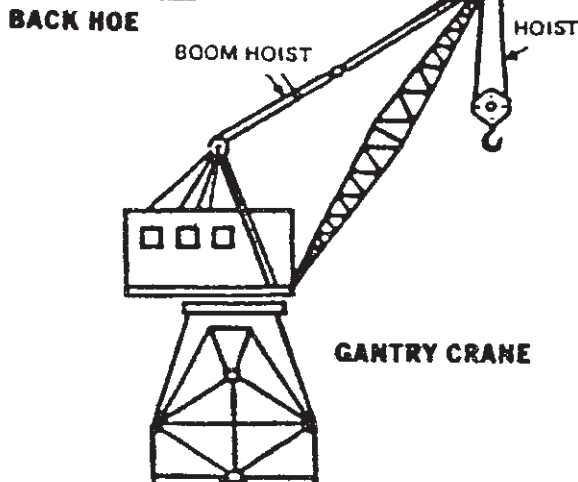
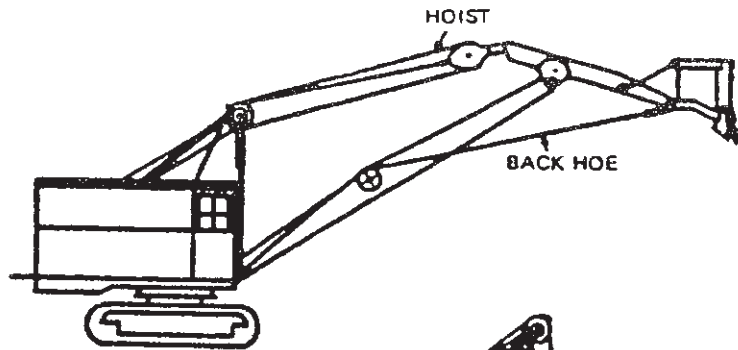

**BUCYRUS - MONIGHAN**

APPLICATION	MFG.-P/N	SP-P/N	SIZE	D.D	PCS/ SET	SETS/ MACH.
<b>9W</b>						
Drag Friction	C11832	84003D	8x1 1/8x8	84E	28	1
Hoist Friction		78002D	14x1 1/4x8	78E	28	1
<b>450W - 480</b>						
Drag Friction		84004D	10x1 1/8x9 3/4	84E	25	1
Hoist & Load Brake		95000D	16x1 1/4x10 3/4	94 <sup>1</sup> / <sub>2</sub> E	20	1
Or		95000KL	16x1 1/4x10 3/4	94 <sup>1</sup> / <sub>2</sub> E	20	1

**KOEHRING**

**405**

Swing & Travel	261D1953-1	21401D	4x3/8x14 1/8 (2)	22N	4	4
Or	261D1953-2		4x3/8x13 3/8 (2)			
		21402	5x3/8x14 1/8 (2)	22N	4	4
			5x3/8x13 3/8 (2)			

**LIMA**

**604, 703**

Swing Friction	472Sx228	22401	6x3/8x14 7/8	23N	4	2
Hoist & Crowd Brake	502SA253	37401	4 1/2x3/8x8 5/8	37E	11	

**1050, 1200**

Swing Friction	472-SY218	31500	5 1/2x1/2x9 3/4	32N	8	6
----------------	-----------	-------	-----------------	-----	---	---

**1250, 1251**

Hoist & Crowd Friction	472-SM218	42502	4 1/2x1/2x9 1/2	43N	12	2
Hoist & Crowd Brake		50500	6x1/2x9 3/4	50E	14	2
Hoist & Drag Brake	4725A-342	33501	6x1/2x17 7/8	34N	4	

**2400**

Hoist & Drag Brake (Late)	502SA-405	68901KL	12x1x7 1/4	68E	23	1
Swing Friction (Late)	472SE-318	45900D	10x1x7 3/8	46N	14	2
Retract Friction	472SC-266	44900	5x3/4x10 5/8	45N	12	1
Hoist & Drag Friction	472SB266	57701	6x3/4x10 3/8	58N	16	2
		22506	6 1/2x1/2x12	22E	5	

**2000C**

		66900KL	8x1x8 1/2	66E	23	
--	--	---------	-----------	-----	----	--

**LORAIN**

**15-K, TL-15, 20K, TL20 (1/2 YD), 25K, TL25, DL26**

Swing Hoist and Friction (some)	D614	15406D	3x3/8x15 15/32	16 1/4N	2	
	LR120					

**L-50, MC-424, MC-504-W**

Hoist Friction	A-30680	232AF	3x1/4x18	25N	4	2
Swing Friction	A-25065	19402	4x3/8x10 1/2	20N	4	2
Boom Hoist Brake	LR-100	232AF	3 1/2x1/4x17 1/4	28E	4	2

**L-85A**

Swing Friction	LR267	23700	5 1/2x3/4x6 1/2 (4)	24N	6	2
			5 1/2x3/4x10 5/8 (2)			
Swing Hoist and Friction (some)	D614	15406D	3x3/8x15 15/32	16 1/4N	2	
	LR120					

**FRICION MATERIAL APPLICATIONS - INDUSTRIAL MACHINES**

**LINK BELT**

APPLICATION	PX #	MFG.-P/N	SP-P/N	SIZE	D.D	PCS/ SET	SETS/ MACH.
<b>HC-48C</b>							
	318		18200	3x1/4x11 3/8	18E	4	
	423	12C180	14402	3 1/2x3/8x13 3/4	14N	2	
<b>LS-58</b>							
	300	CC0525	17418	4x3/8x15 1/4	17 1/4N	2	
<b>LS-68</b>							
	300	CC0525	17418	4x3/8x15 1/4	17 1/4N	2	
Swing & Hoist Friction		CC465	18401	4x3/8x14 13/16	18E	4	
<b>LS-78, HC78A</b>							
Boom Hoist	252		20200	3x1/4x10 3/8	20E	5	
Or	414		23406	3 3/4x3/8x14 1/2	23E	4	
Clutch Friction	321	8C30A					
	416	19C67A	17401D	4 1/2x3/8x9 9/16	18N	8	1
Or		8C57A	19401	4 1/2x3/8x15 15/16 (2)	20N	4	1
		8C58C		4 1/2x3/8x3 1/8 (2)			
Hoist Brake			22202	3 3/4x1/4x15	22E	2	2
<b>LS-98, LS-108</b>							
Swing Hoist	449	1C461B	19404	6 1/2x3/8x8 15/16 (4) RF38	20N	6	6
				6 1/2x3/8x3 15/16 (2) RF12			
Swing Boom Hoist	193		19400	5x3/8x17.4 (2) RF38	20N	4	6
& Retract Friction	325			5x3/8x3 3/8 (2) RF12			
	194	21D99A					
Hoist Brake	372	21D100A	27200	4x1/4x17 1/4	27E	4	1
Or	415	1D755A	27402D	4x3/8x17 1/4	27E	4	1
Or	360		27404	4 1/2x3/8x17 1/4	27E	4	1
Boom Hoist Brake	195	1F0013	22201	3x1/4x12	22E	5	1
<b>LS-128</b>							
	442		25404	6x3/8x14 7/8 (2) RF38	26N	4	
				(2) RF12			
	474	9D281	38504	5x1/2x14	38E	7	
<b>HC-138A</b>							
Boom Hoist Brake	426	19E0039	25403	4x3/8x8 5/8	26N	8	
	425	19D0083	32403	4x3/8x10 1/4	32E	8	
<b>218</b>							
	424	18E60A	29402	4 1/2x3/8x9 3/8	28E	8	
Drum Brake	427	18D136A	36403	4 1/2x3/8x11	36E	8	
<b>238</b>							
Swing		22E52A	25400	5x3/8x9 1/2	28E	8	
Hoist		22D247	34402D	6 1/2x3/8x10 5/8	34E	8	
2 Speed Brake	463		25201	4 1/4x1/4x9 7/8	26N	7	
	377						

**NOTE:** 19400 SETS CAN BE FURNISHED DRILLED. HOWEVER, TO FACILITATE USE ON ALL MODELS, RECOMMEND FURNISHING UNDRILLED.

**LINK BELT**

APPLICATION	MFG.-P/N	SP-P/N	SIZE	D.D	PCS/ SET	SETS/ MACH.
<b>300 SERIES</b>						
Boom Hoist Brake	422 31E30A	30402	4 1/2x3/8x9 1/4	30E	8	
<b>LS-318</b>						
Hoist Brake	421 21B58A	38502	5 1/2x1/2x14 3/4 (4) 5 1/2x1/2x14 15/16 (3)	38E	7	2
	440 9D499AX	38507	5 1/2x1/2x14 3/8 (6) RF38 5 1/2x1/2x7 3/16 (1) RF38 5 1/2x1/2x7 3/16 (1) RF12	38E	8	2
Or		38601	5 1/2x5/8x14 23/32	38E	7	2
Or	21D281	38501	6 1/2x1/2x14 23/32 (7) 6 1/2x1/2x4 (1)	38E	8	2
Travel Brake	431 9C312A	22402D	6x3/8x12 3/8	23N	4	
	432 9D58A	38600	5 1/2x5/8x15	37N	6	2
Swing Friction	412 21D156AX	29600	6 1/2x5/8x16 1/2	30N	4	2
	51C5A	25405	6x3/8x14 13/16	26N	2	
<b>LS-408</b>						
Hoist Friction	432 9D58A	38600	5 1/2x5/8x15	37N	6	2
Hoist Brake	9D66	42500	5 1/2x1/2x15	44E	8	2
Swing Friction	412 21D156AX	29600	6 1/2x5/8x16 1/2	30N	4	2
Or	392 9C71A	29601D	6 1/2x5/8x16 1/2 (2) RF38 6 1/2x5/8x16 1/2 (2) RF12	30N	4	2
Ind. Travel Clutch	193	19400	5x3/8x17.4 (2) RF38 5x3/8x3 3/8 (2) RF12	20N	4	1
		38507	5 1/2x1/2x15 1/8 (6) RF38 5 1/2x1/2x12 31/32 (1) RF38 5 1/2x1/2x7 1/2 (1) RF38 5 1/2x1/2x7 1/2 (1) RF12	44E	9	
<b>LS-418</b>						
Steering Brake	300 CC0525	17418	4x3/8x15 1/4	17 1/4N	2	
	461 9A163A	24200	5x1/4x14 1/2	24E	4	
		27201	4x1/4x15 3/4 (2) 4x1/4x12 3/8 (3)	27E	5	
<b>LS-508</b>						
<b>LS-518</b>						
Steering Brake	300 CC0525	17418	4x3/8x15 1/4	17 1/4N	2	
	461 9A163A	24200	5x1/4x14 1/2	24E	2	
	9D795A	38508	5 1/2x1/2x15 1/8 (6) 5 1/2x1/2x12 31/32 (1) 5 1/2x1/2x7 1/2 (2)	44E	11	
<b>LS-718</b>						
Boom Hoist Brake	438					
	465 32E97A	24508	4 1/2x1/2x15 1/4	24E	4	
	439 32D65A	38506	5x1/2x15 5/8	38E	6	
<b>3000, 3500</b>						
	417 25C138A	17419	5x3/8x9 1/4	17 1/4N	4	

NOTE: 19400 SETS CAN BE FURNISHED DRILLED. HOWEVER, TO FACILITATE USE ON ALL MODELS RECOMMEND FURNISHING UNDRILLED.

FRICITION MATERIAL APPLICATIONS - INDUSTRIAL MACHINES

**MANITOWOC ENGINEERING**

APPLICATION	MFG.-P/N	SP-P/N	SIZE	D.D	PCS/ SET	SETS/ MACH.
<b>1500</b>						
Hoist or Crowd Friction		232AF	3x1/4x87	30E	1	2
Hoist or Crowd Brake	3252	232AF	3x1/4x66	30E	1	2
Booster	3889	232AF	1 1/2x1/4x39 1/2	15E	1	
Retract Friction		F18150	18 5/8x11 1/2x1/4	180° Seg	2	2
<b>1600, 1615</b>						
Hoist & Crowd Friction		232AF	3 1/2x1/4x11 1/2	30E	6	2
Hoist or Crowd Brake		232AF	3 1/2x1/4x11 1/2	30E	6	2
Boom Hoist Brake		232AF	2 1/4x1/4x40	13E	1	1
Retract Friction		F18150	18 5/8x11 1/2x1/4	180° Seg	2	2
<b>2000, 2300, 2800, 2900</b>						
Hoist & Crowd Friction	3253	30400	3 1/2x3/8x11 15/16	30E	7	2
Hoist & Crowd Brake	17558	30400	3 1/2x3/8x11 15/16	30E	7	2
Boom Hoist Brake	3173	232AF	2 1/4x1/4x34	12E	1	1
Retract Friction		F18150	18 5/8x11 1/2x1/4	180° Set	2	2
<b>3000, 3500, 3600, 3900, 4000</b>						
Hoist or Drag Friction	20492	42400D	3 1/2x3/8x14 1/2	42E	8	2
Or	508400	42405D	3 1/2x3/8x14 1/2	42E	8	2
Or		42401	4x3/8x14 1/2	42E	8	2
Or		40500	5x1/2x11 9/64	40N	9	2
Or		40400	5x3/8x11 9/64	40N	9	2
Hoist or Drag Brake	20495	42402	4 1/2x3/8x14 1/2	42E	7	2
Or	22662	46502	6x1/2x16 1/4	46E	8	2
Boom or Hoist Brake	20298	232AF	2 1/4x1/4x18 1/4	14E	1	1
Swing Friction	31065	F27300	27 7/8x19 1/8x5/16	90° Seg	4	
Retract Friction	3132	F18150	18 5/8x11 1/2x1/4	180° Seg	2	
<b>4500, 4600</b>						
Hoist or Drag Friction	14488	48700KL	9x3/4x10	49N	14	1
Or	14487	48701KL	8x3/4x10	49N	14	1
Or		48603	7 3/4x5/8x10	48 1/2N	14	
Or	77715	48604	8x5/8x23 <sup>25</sup> / <sub>32</sub>	49N	14	
Hoist or Drag Brake	14461	52700KL	10x3/4x9 3/4	52E	15	1
Or		52800KL	10x7/8x9 3/4	52E	15	1
Or		52900KL	10x1x9 3/4	52E	15	1
Or		52701KL	9x3/4x9 3/4	52E	15	1
Swing Brake	18066	40700KL	7 1/2x3/4x14 1/4	40N	4	1
Swing Friction	15668	39700KL	7 1/2x3/4x14 1/4	40N	8	2
Or		39800KL	7 1/2x7/8x14 3/8	40N	8	2
Or		39900KL	7 1/2x1x14 7/16	40N	8	2

**MARION SHOVEL**

APPLICATION	MFG.-PIN	SP-P/N	SIZE	D.D	PCS/ SET	SETS/ MACH.
<b>93M</b>						
Hoist & Drag Friction	10F216	39501D	5x1/2x8 1/4	40N	12	2
Boom Hoist Brake		232AF	3x1/4x80 3/8		1	1
<b>111</b>						
Hoist & Drag Friction	10F217	51500	5x1/2x7 1/2	52N	18	2
Hoist Brake (Some)	10F323	60700KL	8x3/4x12	60E	12	1
Hoist & Crowd Brake (Early)	10F219	60500D	6x1/2x123/4	60E	12	
<b>183</b>						
Hoist & Drag Friction	10F284	66700D	6x3/4x10 3/4	66E	15	2
Hoist & Drag Brake	10F294	70800KL	12x7/8x11 7/8	70E	15	1
Hoist Brake		70900KL	12x1x11 7/8	70E	15	
<b>184</b>						
Hoist & Drag Friction	10F364	66701D	8x3/4x10 3/4	66E	15	2
Drag Friction	10F328	70801KL	9 1/2x7/8x11 7/8	70E	15	1
Or		70901KL	9 1/2x1x11 7/8	70E	15	
Hoist Brake	10F294	70800KL	12x7/8x11 7/8	70E	15	1
Or		70900KL	12x1x11 7/8	70E	15	
Drag Friction		70901KL	9 1/2x1x11 7/8	70E	15	1
<b>191</b>						
Hoist Friction	10F308	16500	6x1/2x8 3/8	16E	15	1
<b>191M</b>						
Hoist Brake	57G150	39502	9x1/2x14 1/2	39E	8	
Swing & Crowd	RL5850	12300	2 3/8x5/16x8 1/2	12E	2	
		51501	8x1/2x12 3/8	52N	14	
Hoist Check Brake		232AF	10x1/2x60			
<b>7400</b>						
Hoist Friction	10F239	68700D	8x3/4x12	68E	15	1
Hoist Brake (Early)	10F135	84000D	14x1 1/2x11 3/4 (16)	84E	17	1
			14x1 1/2x8 1/2 (1)	84E		
Or		84000KL	14x1 1/2x11 3/4 (16)	84E	17	1
			14x1 1/2x8 1/2 (1)	84E		
Hoist Brake (Late)	10F179	90000D	7 3/4x1 1/2x12 (34)	90E	36	1
			7 3/4x1 1/2x9 (2)	90E		
<b>8250</b>						
Hoist & Drag	10F320A	28500D	6x1/2x6 1/2 (4)	28E	6	
			6x1/2x9 (2)			
<b>8750</b>						
Swing	10F336	28600D	6x5/8x111/8	28E	2	



**FRICION MATERIAL APPLICATIONS - INDUSTRIAL MACHINES**

**NORTHWEST ENGINEERING**

APPLICATION	MFG.-P/N	SP-P/N	SIZE	D.D	PCS/ SET	SETS/ MACH.
<b>4,5,6</b>						
House Brake	120405	C22300D	5/16x19" I.D.x22" O.D.	60°	4	2
Hoist & Crowd Friction	420411	HDMAF	4x1/2	30N	4	1
Hoist Brake	410726C	232AF	4 1/2x5/16	36E	5	1
Swing Friction	123578C	F22456	22 1/2 O.D.x14 I.D.x1/2	180° Seg	2	1
Retract Friction	110393B	HDMAF	3x1/2x7 1/2	22N	8	1
Or	*212181D	26501RD	4 1/2x1/2x17 13/64	27N	4	1
<b>8</b>						
Hoist & Crowd Friction	120410C	HDMAF	4x1/2	30N	5	1
Hoist Brake		232AF	5x3/8	44E	2	1
Swing Friction	313719	F238	23 3/4 O.D.x15x1/2 I.D.	180° Seg	2	3
Drag Friction	211597B	HDMAF	4x1/2x18 1/4	38N	6	1
Retract Brake		HDMAF	2 1/2x3/8x94		1	2
<b>25D</b>						
Swing Friction		F1625	3/8x11 3/4 I.D.x16 3/4 O.D.	180°	2	1
Swing Brake		HDMAF	2 1/2x1/4x30 1/2	11E	1	
Hoist Brake		HDMAF	4x1/4x6 1/2 (2) 4x1/4x34 (1) 4x1/4x37 (1)	27E	4	
<b>28</b>						
Hoist Brake		HDMAF	4x1/4x6 1/4 (1) 4x1/4x10 1/4 (1) 4x1/4x24 5/8 (1)		3	
<b>41</b>						
Swing, Travel & Boom Hoist Fric.	231961	F1930	1/2x13" I.D.x19 1/2" O.D.	180°	2	6
Hoist Brake		HDMAF	3 3/4x5/16x45 3/4 (1) 3 3/4x5/16x47 (1)	31 E	2	
Hoist Friction		HDMAF	3 1/2x5/16x16 1/2 (2) 3 1/2x5/16x20 (2)	25N	4	
Booster		HDMAF	3 1/4x1/4x19	14E	3	
Swing Brake		HDMAF	2 1/2x1/4x30	11E	1	
Swing Friction (Some)	221125B	F1941D	1/2x14 1/2 I.D.x19 1/2 O.D.	180°	2	6
<b>50D</b>						
		27502	3 1/2x1/2x17 1/4	28N	4	
<b>80D, 850, 950</b>						
Hoist Friction RH	211597B	HDMAF	4x1/2x18 1/4	38N	6	1
Hoist Friction LH		HDMAF	4x1/2	30N	5	1
Hoist Brake		HDMAF	5x1/2	44E	6	1
Swing Friction	313719	F238	23 3/4 O.D.x15x1/2 I.D.	180° Seg	2	3
Or	325729	F2680D	26 1/4 O.D.x17 3/4 I.D.x1/2	90° Seg	4	2
Retract Friction	*	26501RD	4 1/2x1/2x17 1/4	27N	4	1
	*228621	41501RD	4x1/2x14 1/2 (6) 4x1/2x5 3/16 (6)	42N	12	1
Or						
Drum Brake	256636	48601	5x5/8x11 7/8	48E	1	
	*223717-2	10200RD	3x1/4x6 (6) 3x1/4x8 1/4 (6)	10 <sup>1</sup> / <sub>2</sub> E	12	
Dipper Trip Clutch	119473	F904	3/8x6 1/2 I.D.x9 7/80 O.D.		1	
Hoist Brake R.H.&L.H.		44504	5x1/2x10 1/2	44E	9	2
Or		44600	5x5/8x10 1/2	44E	9	2
Retract Friction		41501D	4x1/2x14 1/2 (6) 4x1/2x5 3/16 (6)	42N	12	

**NORTHWEST ENGINEERING**

APPLICATION	MFG.-P/N	SP-P/N	SIZE	D.D	PCS/ SET	SETS/ MACH.
<b>180D (Early)</b>						
Hoist Friction	232170	HDMAF	5x1/2x22 7/8	48N	6	2
Or	235823A	58600	6x5/8x12 1/4 (1)	58E	11	2
	235824A		6x5/8x12 15/16 (6)			
			6x5/8x12 1/4 (4)			
<b>Swing Friction</b>						
	332192A	F31180D	31 1/2 O.D.x20 1/2 I.D.x1/2	60° Seg	6	6
Hoist Brake R.H.&L.H.		44504	5x1/2x10 1/2	44E	9	2
Or		44600	5x5/8x10 1/2	44E	92	2
<b>180D (Late)</b>						
Hoist Brake & Crowd	240361	56700D	6 1/2x3/4x12 1/4	56E	10	2
<b>190D</b>						
Hoist Brake	*23727D	58700BD	6 1/2x3/4x5 7/8 (2)	58E	22	2
Or	*23727D	58700RD	6 1/2x3/4x4x11 5/8	58E	12	2
Hoist Brake R.H.&L.H.		44504	5x1/2x10 1/2	44E	9	2
Or		44600	5x5/8x10 1/2	44E	9	2
<b>9570</b>						
Hoist Brake R.H.&L.H.		44504	5x1/2x10 1/2	44E	9	2
Or		44600	5x5/8x10 1/2	44E	9	2
Hoist Brake & Crowd	240361	56700D	6 1/2x3/4x12 1/4	56E	10	2

**NOTE:** Due to changes in OEM specifications parts can be drilled for either bolts or rivets.  
RD after set number indicates rivet drilling. BD after set number indicates bolt drilling. Sets are available undrilled

**P AND H**

APPLICATION	MFG.-P/N	SP-P/N	SIZE	D.D	PCS/ SET	SETS/ MACH.
<b>55TC</b>						
Swing Friction	1015T13	12401	2 1/2x3/8x13 3/4	12 <sup>1</sup> / <sub>2</sub> N	2	2
Hoist Friction	1015T12	14401	2 1/2x3/8x17	15N	2	2
Boom Hoist Brake	1015T10	13301	2 1/4x5/16x9	13 <sup>1</sup> / <sub>4</sub> E	4	1
Third Drum Brake	1015T70	13301	2 1/4x5/16x9	13 <sup>1</sup> / <sub>4</sub> E	4	1
<b>155TC</b>						
Carrier Brakes	Front	4286D				
Carrier Brakes	Rear	4514D				
<b>210</b>						
		17421	3x3/8x8 3/4	18N	6	
<b>320</b>						
Hoist & Digging Clutch	1015T73	22400	3x3/8x11 1/8	23N	6	2
Swing Friction	1015T75	17405D	3x3/8x17 29/32	18N	2	2
Or		17406	4x3/8x5 15/16	18N	6	2
<b>325TC</b>						
Swing Friction		15402	3x3/8x11	16N	2	2
Swing Brake		232AF	2x1/4x22 1/2			
Boom Hoist Friction & Brake		HDMAF	2 1/2x3/8x56	19E	1	
Hoist & Crowd Brake		24404	3 1/2x3/8x16	24E	5	2
Carrier Brakes	Front	4286D				
Carrier Brakes	Rear	4515D				

FRICITION MATERIAL APPLICATIONS - INDUSTRIAL MACHINES

**P AND H**

APPLICATION	MFG.-P/N	SP-P/N	SIZE	D.D	PCS/ SET	SETS/ MACH.
<b>955</b>						
Hoist, Crowd & Drag		HDMAF	4 1/2x1/2x18 5/8 (4) 4 1/2x1/2x17 5/16 (1)	35E	5	2
Or	15P675 1015T46	HDMAF	4x3/8x17 1/4	36N	6	2
Or	15P993	HDMAF	6x1/2x20	42N	6	1
Travel Friction		232AF	3 1/2x5/16x57	22E	1	
Master Friction		232AF	4 1/2x5/16x65	24N	1	1
Hoist, Crowd & Drag Brake	15P676 } 15P677 }	40501	6x1/2x15 3/8 (3) 6x1/2x17 1/4 (3)	40E	6	1
Or	15P838C1	40502	6x1/2x11 7/8	40E	10	3
Swing Brake	3-4-915P20	HDMAF	2 1/2x5/16x72	27E	1	1
Boom Hoist Brake		232AF	3x1/4x26	10E	1	
Or		232AF	2 3/4x5/16x16	12E	2	2
Propel Brake	15Z308	24403	5x3/8x13 1/4	24E	1	1
Boom Hoist & Planetary Fric.	1015T48	32301	3x5/16x11 9/16	32E	1	1
Auxiliary Friction	15P818C1	232AF	2 3/4x1/4x14			
For Hoist & Digging						
Swing Friction (Some)		HDMAF	4x3/8x17 1/4	35E	6	1
Hoist & Digging Brake	1015T66	41502	7 1/2x1/2x12 3/16	41E	10	1
<b>1400</b>						
Hoist Brake		HDMAF	8x1/2x43 1/2	40E	2	2
Boom Hoist Brake		232AF	3x1/4x26	10E	1	1
<b>1500</b>						
Hoist Friction		HDMAF	3 1/2x3/8x94	32E	1	2
Propel Brake		HDMAF	6x3/8x40	28E	2	1
<b>1800</b>						
Swing & Crowd	15H183C1	13401	6x3/8x11	13E	2	
<b>1900</b>						
Propel Brake	15N723	C42550D	1/2"x33 7/16 I.D.x42' O.D. (45°)		4	2
Hoist	15F207F1	21502D	9 1/2x1/2x17 1/2	21E	1	
Swing & Crowd	15H183C1	13401	6x3/8x11	13E	2	
<b>2100</b>						
Propel Brake	15N725	C44550D	1/2"x35 7/16 I.D.x44" O.D. (45°)		4	2
Crowd Friction (BL&BLE)	15F386	16502D	6 1/2x1/2x13 3/8	16E	2	
Swing Friction (BLE)	15H449C3	13400D	5 1/2x3/8x10 3/4	13E	2	
Or (BL)	715U1D8	13401D	6x3/8x11	13E	2	
Hoist	15F207F1	21502D	9 1/2x1/2x17 1/2	21E	1	
<b>2300</b>						
Propel Brake	15N725	C44550D	1/2"x35 7/16 I.D.x44" O.D.(45°)		4	2
Crowd	15F386	16502D	6 1/2x1/2x13 3/8	16E	2	
Swing Friction	15H449C3	13400D	5 1/2x3/8x10 3/4	13E	2	
Propel Motor Parking	15F394	19501D	8 1/2x1/2x15 3/4	19E	2	
Hoist	15F207F1	21502D	9 1/2x1/2x17 1/2	21E	1	
Swing & Crowd	15H183C1	13401D	6x3/8x11	13E	2	
<b>2800</b>						
Propel Brake	15N766D2	C50500	5/8x41.314 I.D.x50.7140 O.D.(42°)		4	
5100	1015T 142-1	32409	5x3/8x8 7/8	32E	10	
<b>8115, 9125, 9150</b>						
Hoist Friction		38400D	5x3/8x11 1/2	38E	20	

**PAGE ENGINEERING**

APPLICATION	MFG.-P/N	SP-P/N	SIZE	D.D	PCS/ SET	SETS/ MACH.
<b>721</b> Hoist Friction	32558-D	68702D	10x3/4x11 3/4	68E	15	1
<b>725</b> Drag Friction	ROXL31	61700D	8x3/4x12	61E	14	1
Hoist & Drag Brake		78000KL	16x1 1/4x12	78E	14	1
<b>728</b> Hoist & Drag Friction		68702D	10x3/4x11 3/4	68E	15	1

**UNIT CRANE**

<b>271C</b>	202786	20302D	2 1/4x5/16x7 3/16	20E	16	
<b>357, 514, 1020</b> Operating Clutch	22702A	GT14802	14 15/16 O.D.x9 1/4 I.D.x5/8 (88 Teeth)		1	5
<b>1020, 1020A (Some)</b> Swing, Travel, Crowd & Retract Friction	201821	GT14801	14 7/8 O.D.x9 1/4 I.D.x5/8 (44 Teeth)		1	5
<b>614, 617, 1014</b> Swing, Travel, Crowd & Retract Friction	22702A	GT14802	14 15/16 O.D.x9 1/4 I.D.x5/8 (88 Teeth)		1	5
<b>620</b> Swing, Crowd Propel & Retract Friction	22702A	GT14802	14 15/16 O.D.x9 1/4 I.D.x5/8 (88 Teeth)		1	20
<b>761C</b>	202786	20302D	2 1/4x5/16x7 3/16	20E	16	
<b>940</b> Swing Friction	22702A	GT14802	14 15/16 O.D.x9 1/4 I.D.x5/8 (88 Teeth)			1 As Required
<b>1220</b>	202702	17300D	2 1/4x5/16x7 1/2	17 3/4 E	14	2

**WASHINGTON**

		80004D	12 1/2x1x5 1/4 (1)	80E	27	
			12 1/2x1x7 1/2 (26)	80E	28	
			12 1/2x1x5 1/4 (2)			

## Brass Keeper Strips & Brass T-Bolt Assemblies

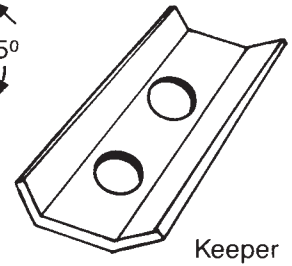
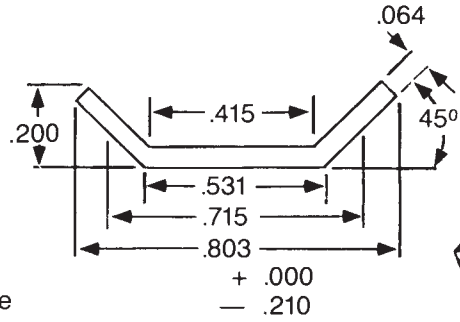
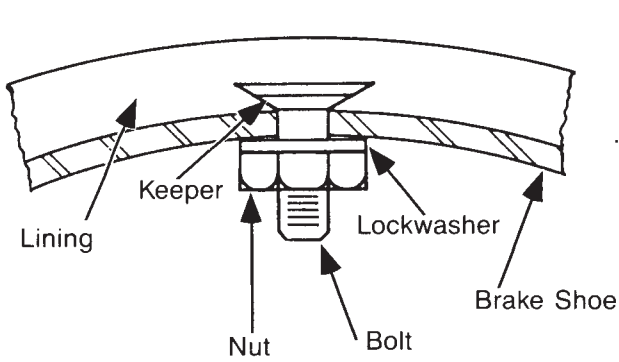

Keeper Detail ( $7/8$ "')

Cross Section of Key-Locking Assembly

Hardware Furnished in Kits and Sets Only.





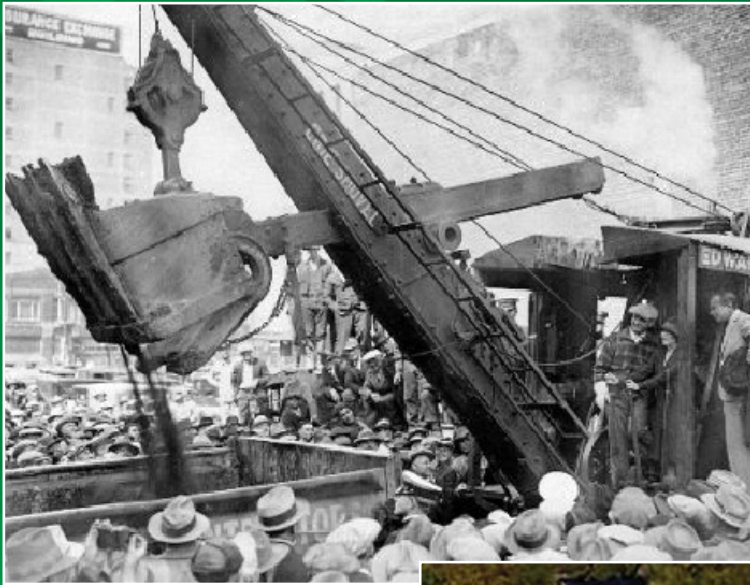

N84 W13510 Leon Rd.  
Menomonee Falls, WI 53051

Toll Free: (888) 880-6388

Phone: (262) 255-2525

Fax: (262) 255-2528

E-Mail: [sales@scanpac.com](mailto:sales@scanpac.com)

Web Site: [www.scanpac.com](http://www.scanpac.com)

**The  
Pioneer In  
Asbestos-  
Free  
Products**

