

DEMAG

Cranes & Components

Demag DC-Pro Chain Hoist Demag DCM-Pro Manulift

The New High Performance Hoists



Demag hoist units: Perfect load handling

High productivity, efficiency and reliability are the most important requirements for state-of-the-art material handling systems. Demag Cranes & Components

develops and produces material handling solutions for all industries and for companies of all sizes, from small workshops to major industrial corporations.

Contents

DC-Pro Chain Hoist

A New Industry Standard	1
Standard Features	2 – 3
Increased Performance, Faster Speeds	4
Improved Safety and Reliability	5
Control Pendant	6 – 7
Commissioning and Maintenance	8 – 9

DCM-Pro Manulift

DCM-Pro Manulift	10 – 11
------------------	---------

Accessories

Pillar and Wall-mounted Slewing Jibs	12 – 15
KBK Track and Crane Installations	16 – 17
Trolleys and Electric Drives	18 – 21
Clamp-fitted Buffers and Magnets	22
Service	23

Technical Data and Selection Tools

Selection Criteria	24 – 25
Technical Data, Selection and Dimension Tables	26 – 33
Hoist Designer/e-tools	34
Fax service	35



Demag DC-Pro chain hoist

A New Industrial Standard

All inclusive: popular options are standard

Many of the most popular features are integrated into the Demag DC-Pro chain hoist as standard; where as in other hoists they are optional.

The DC-Pro chain hoist is a fully featured, highly versatile chain hoist, which can be installed and put into service in a minimal amount of time.



That is “Standard – Made by Demag”, an investment with added value.

- The Demag **2m⁺** provides 20% longer service life and greater efficiency
- 24 V contactor control and operating limit switches improve safety and reliability
- Height-adjustable control cable allows for 10’ of adjustment without the need to rewire
- Two suspension bracket sizes allows for the flexibility of mounting to a variety of trolleys
- Plug & Lift and Plug & Drive quick disconnects make installation and commissioning simple
- Gearbox, brake and slip clutch are maintenance-free for up to 10 years
- Smooth and fast load handling of loads with two hoist speeds
- Elapsed operating time counter and diagnostics interface provide information on the operating status – for scheduling planned maintenance
- The chain drive assembly can be replaced quickly and easily

Standard Features

Certified

DC-Pro chain hoists are tested and approved by several standard authorities and also meet the demanding requirements of the CSA specifications. Electromagnetic compatibility is rated according to EN 61000-6-2 to 4 for interference immunity in industrial environments and for interference emissions in commercial and industrial environments.

The hoist motor, chain hoist and travel drive with IP55 enclosure and control pendants with IP65 enclosure to EN 60529 ensure high protection against moisture and dust penetration.



① **Gearbox** – maintenance-free for up to 10 years. With an FEM Group of Mechanisms classification of 2m+, the DC-Pro sets a new standard with a rated service life of 1900 full load hours. In practical terms, this means the service life is extended by approx. 20%. The helical gearing inside the gearbox also reduces operating noise and provides smooth operation.

② **Brake** – maintenance-free for up to 10 years (sizes DC 10–25 up to 5 years). Thanks to minimum wear, adjustment is not necessary; short and gentle run-on path. The brake is enclosed in the electrical panel and provides double protection from the elements.

③ **Slip clutch** – maintenance-free for up to 10 years. Integrated behind the brake in the power drive, it provides reliable protection against overload. Integrated slip clutch monitoring prevents permanent damage to the slip clutch.

④ **Height adjustable control pendant cable** – The length of the control cable and, therefore, the suspension height of the control pendant can be infinitely varied for a hook path range of 6.56–16ft (2–5m) and 16–26 ft (5–8m). The excess control cable (not required) is accommodated behind the service cover. The control cable is rated for electric travel applications in 3 axes.



⑤ **Control** – 24 V contactor control, operating limit switches (upper/lower) and elapsed operating time counter are standard on DCI-10. A geared limit switch with four contacts for fast-to-slow and limit cut-off is used as the operating limit switch on sizes DC 16 and 25.

⑥ **Round steel chain** – a special Demag chain of high-strength, hardened age-resistant material surface. Galvanized and other surface-treatment are available to protect against specific hostile environments.

⑦ **Suspension bracket** – DC-Pro chain hoists are suspended in pendulum fashion and make optimum use of the available height thanks to their low headroom dimension. DC-Pro units are supplied with short and long suspension brackets as standard and can always be attached to the superstructure with the optimal connection.



⑧ **Housing** – robust and weight-saving die-cast aluminium housing of compact and modern industrial design. UV-resistant powder-coated finish is resistant to nicks and scratches.

⑨ **Hoist motor** – high-performance motor with large safety reserves even at high ambient temperatures and in prolonged operation. 2 hoist speeds with 4/1 ratio as standard. (Insulation class F, 360 s/h and 60% CDF)

⑩ **Chain drive** – The unit is a complete assembly consisting of the chain and chain guide which facilitates quick and easy replacement of the entire chain drive without having to remove the motor or gear parts. Downtime can therefore be reduced significantly. The chain drive consists of highly wear-resistant materials for a long service life.



⑪ **Chain collector box** – suspended from a pivoting connection, is made of tough, flexible and particularly impact-resistant plastic; capacity for up to 26ft (8m) hook path. A flexible chain container for chain lengths up to 131ft (40m) as well as special lengths up to 393ft (120m).

⑫ **Bottom block** – hoist up to 2200 lb (1000 kg) are supplied with single chain fall for improved ergonomic handling of the hook. Chain wear is simultaneously reduced, since no chain return arrangement is required. The new, compact and particularly ergonomic DC bottom block is used for 2/1 reeving arrangements. The cut-off springs required for the limit switches are integrated inside the bottom block and therefore save 2.36in (60mm) of the valuable headroom dimension.

Increased performance, faster speeds



Increased performance, improved ergonomics, safety, and reliability for greater productivity. The performance features of the new DC-Pro chain hoist provide for optimum efficiency.

Sensitive and fast

DC-Pro units can be integrated into your work and production processes flexibly and precisely. While the high lifting speed guarantees fast and effective operation at a minimum of 6 ft/min, the slow lifting speed ensures that loads are placed gently and precisely.

2m⁺ – an even longer service life for greater efficiency.

In practical terms, Demag 2m⁺ means the service life is extended by approx. 20% in comparison with the conventional 2m classification for chain hoists FEM rating. This results in significantly prolonged time between service intervals and general overhauls. This extra operating life is only offered by the new Demag DC-Pro chain hoist.

Duration of service in full load hours

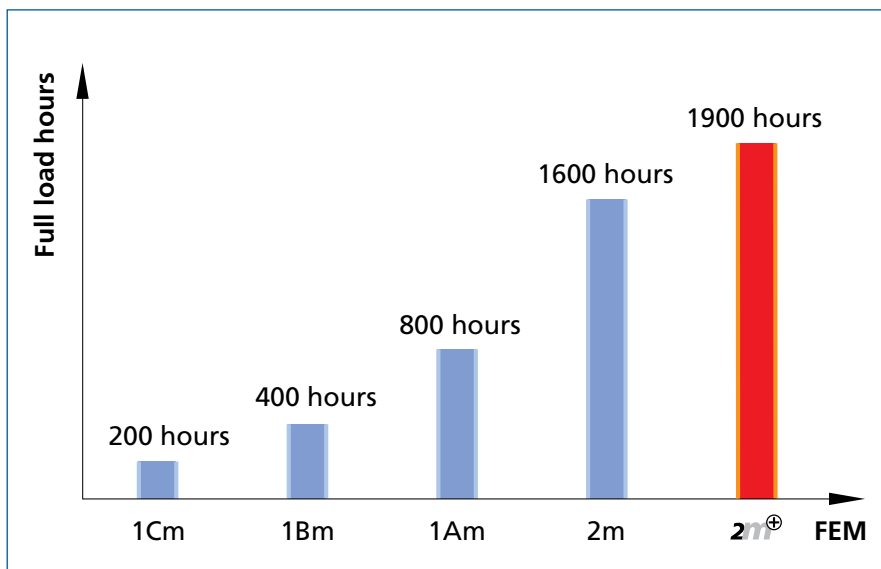

Improved safety and reliability

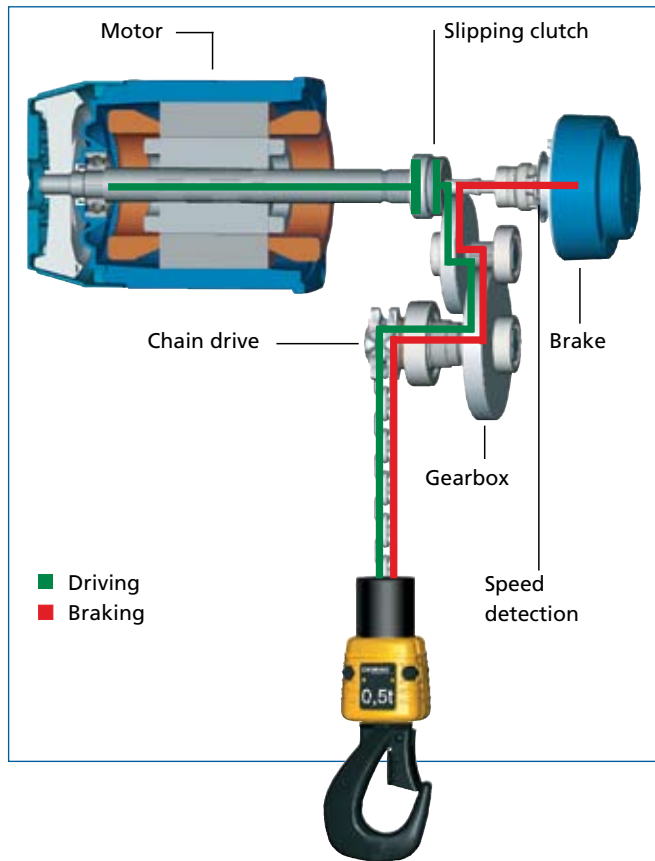

Thanks to the completely new safety concept developed for the Demag DC-Pro chain hoist, the gearbox, brake and coupling operate maintenance free for up to ten years (brake for sizes DC 10–25 up to 5 years). The brake-coupling system ensures that the load is held securely in any operating situation. The load cannot drop. This is achieved by the arrangement of the brake directly in the power drive chain (red line). Thanks to regenerative braking which minimizes wear, the brake never requires adjustment. Operating safety is generally improved by the single-fall design up to a load capacity of 2200 lb (1000 kg).

The combination of electronic control system and integrated speed sensors continuously monitor the hoist motor, clutch and brake, thus ensuring operator safety. The compact and light 24 V contactor control system also ensures that the system is subject to only minimum wear.

The standard control system includes

- 24 V contactor control
- Operating limit switches (upper/lower) to switch the hoist motion off in the highest and lowest hook positions – sizes DC 16 and 25 with a geared limit switch with four contacts for fast-to-slow and limit cut-off
- Elapsed operating time counter can be read from the outside via the 7 segment display
- Speed detection
- Infrared diagnostics interface

Control pendant: Always at the right operating height



Height adjustment of the control cable

The most favorable operating height for the control pendant can be easily adjusted on the Demag DC-Pro chain hoist. The adjusting mechanism integrated in the chain hoist housing enables the operator to change the suspension height of the control pendant easily and without the need for any tools or rewiring. The control cable is designed for an adjustment range of 10 ft (3 m). The length of control cable that is not required stores behind the DC-Pro service cover. This innovation has been implemented for the first time in a chain hoist.

The adjusting mechanism also contains the strain relief arrangement for the control cable and can resist extreme tensile loads. The same applies to the control cable, which is made of a proven and particularly tough material. At the same time, the control cable is flexible and therefore easy to handle.

Ergonomics: All in good hand

The DSC control pendant precisely interprets control commands in any situation. It facilitates fatigue-free operation for right and left-handed operators both with and without gloves. Furthermore, electrical interlocks prevent simultaneous initiation of motions in both directions.

Demag control pendants feature an optimized ergonomic sloping design for convenient operation. They are made of high-quality plastic which is highly resistant to impacts and are therefore extremely durable. With bending and impact protection as well as an IP 65 enclosure that protects against dust and moisture, DSC units are ideally suited for the demanding requirements of industrial applications. The DSC control pendant is specially developed for push-travel DC-Pro chain hoists and fitted with two-stage buttons. The DSE 10-C control pendant is used for electric travel applications with E 11/E 22 or E 34 drives.



The control pendant can be changed quickly and easily



Slide the protective sleeve upwards over the control cable



Fit the plug with its bayonet connector into the control pendant and turn until it locks



Push protective sleeve downwards

Commissioning: Plug & Lift and Plug & Drive

A great benefit offered by the new Demag DC-Pro chain hoist is simple commissioning. The pivoting suspension bracket and infinitely adjustable flange width of the U 11, U 22, U 34 and U 56 trolleys make the mechanical parts easy to install.

The plug-in connections beneath the service cover and the power plugs, included in the scope of delivery, make the electrical parts simple to connect. This enables the DC-Pro to be ready for operation in a minimum of time.



Pivoting service cover

Integrated beneath the cover

You have quick access to all important components for service and commissioning beneath the service cover.

- Storage for 10 ft (3 m) of control cable
- Plug-in electrical connections for power cable, pendant cable, limit switches and trolley
- Strain relief for power supply and trolley supply cables
- Chain guide
- Chain lubrication

Maintenance: Fast and simple

All main drive components of the Demag DC-Pro chain hoist, such as the gearbox, brake and coupling, operate without the need for any maintenance for up to ten years (maintenance-free brake for up to 5 years for sizes 10–25). The outstanding Demag quality of all components provides for a long service life even under heavy use. The few preventative maintenance measures can be carried out quickly and easily thanks to the service-friendly design of the DC-Pro.

The chain drive of the DC-Pro, for example, is designed as a compact unit which is slid into place and can be replaced in a minimum of time without the need to disassemble motor or gearbox parts. Long downtimes as a result of maintenance work are now a thing of the past.

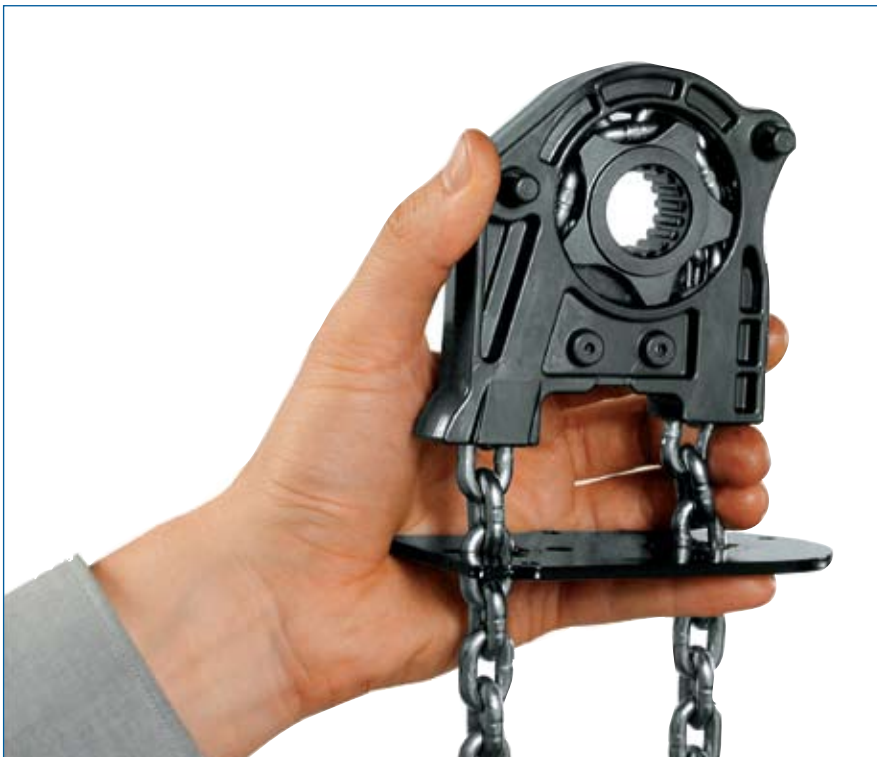

Chain drive

Diagnosis – wireless via display or via infrared

Service technicians can read the standard operating time counter or call up the relevant information on the operating status – from the outside via the display on the base of the chain hoist housing or by means of the diagnosis interface via infrared data transfer.



Diagnosis interface

Demag DCM-Pro Manulift:

Safe, fast and ergonomic single-handed load handling at the workplace

The DCM-Pro Manulift was developed for handling loads quickly and safely with only one hand. The new DCM-Pro is based on the DC-Pro chain hoist and the DSM-C control unit which is connected to it by a helical cable. The control unit is rigidly connected to the load handling attachment for right and left-handed operation, the operator only needs one hand to operate the chain hoist and guide the load.

The quick-disconnect coupling enables a wide variety of load handling attachments to be changed with ease. All Manulift load handling attachments are fitted with a connecting pin with a swivel lock, which snaps into the quick-disconnect coupling. It can be easily removed by lifting the unlocking sleeve.

Manulift units can travel on Demag KBK profile sections and I-beams (see pages 16 – 23), which enables them to be flexibly integrated into work and production processes.

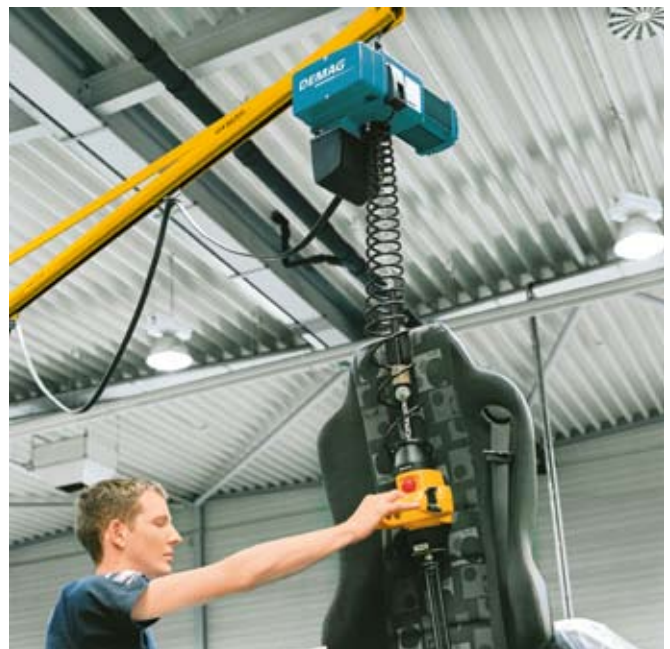

Load hook
250 kg



Slewing load hook
250 kg



Open hook
125 kg



Belt sling
125 kg

Versatile adaptability to any task

A variety of proven load handling attachments facilitate optimum and flexible adaptation of the “Manulift” chain hoist to meet your needs. They range from normal load hooks and various pantograph-type tongs to parallel gripper systems. The DCM-Pro Manulift can be used with specially developed load handling attachments.

The universal coupling pin is used to connect customer-designed attachments. It is provided with an M12 internal thread for connecting special load handling attachments.

Manulift load handling attachments can also be connected to the DC-Pro chain hoist load hook by means of an adapter. The versatility and flexibility of the new Demag chain hoist provide for improved load handling efficiency at the workplace.

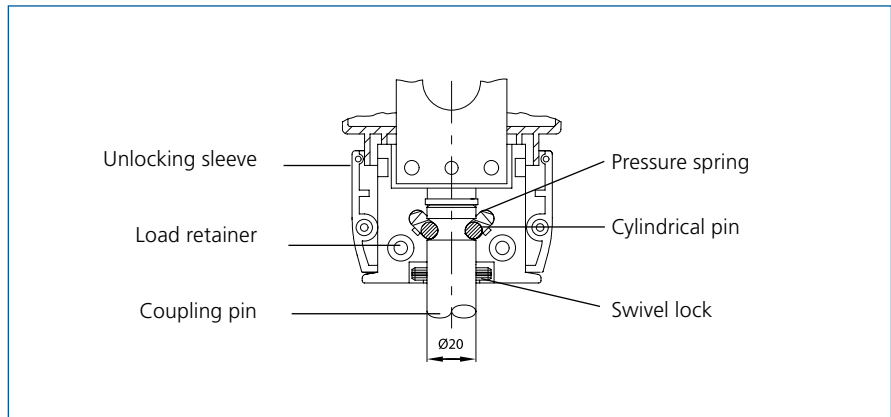

The quick-change coupling on the DSM-C control unit



PGS-parallel gripper
125 kg



Pantograph tongs for gripping square goods
125 kg



Pantograph tongs for gripping round goods
125 kg



Load hook adapter
up to 250 kg



Load hook adapter with connected PGS shaft gripper

PGS parallel gripper system: Firm hold on loads up to 125 kg

PGS box grippers

The narrow design and short opening path of the grippers make it possible to pick up and deposit goods safely and easily, even in restricted spaces, and place them direct into cartons. The 4(100 mm) wide gripping range makes it possible to transport both the actual goods as well as a packed unit using the same gripper.



PGS shaft grippers

Various shaft grippers are available which can be adapted to different shaft types and applications by changing the gripper jaws.

When fitted with a shaft support, they can be used to pick up shafts with various diameters or an unknown center of gravity. This significantly improves the safety of handling tasks that, until now, have always involved a certain risk.

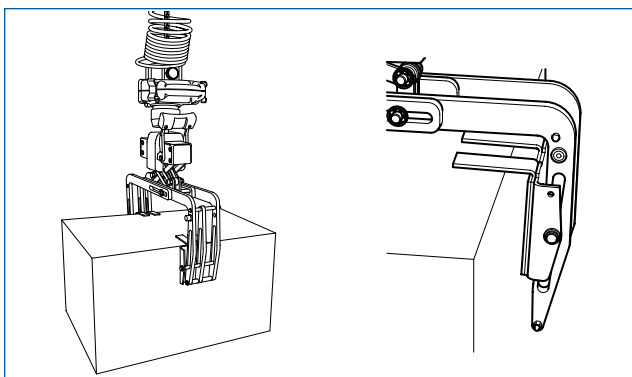

PGS container grippers

The various container grippers can be supplied for fixed or adjustable container widths. They are easily adjusted to the relevant container size by lifting and turning the locking pins, and by pushing the grippers together or pulling them apart until the stops are reached.

Container type	Container size	
	600 x 400	400 x 300
Euro container	rigid	rigid
KLT (VDMA)	rigid	rigid
	adjustable	
Various containers such as PDB, ARCA, MF, SSI Schäfer, Eurotec, Utz KLT, Bito	rigid	rigid
	adjustable	

Grippers for other container types on request

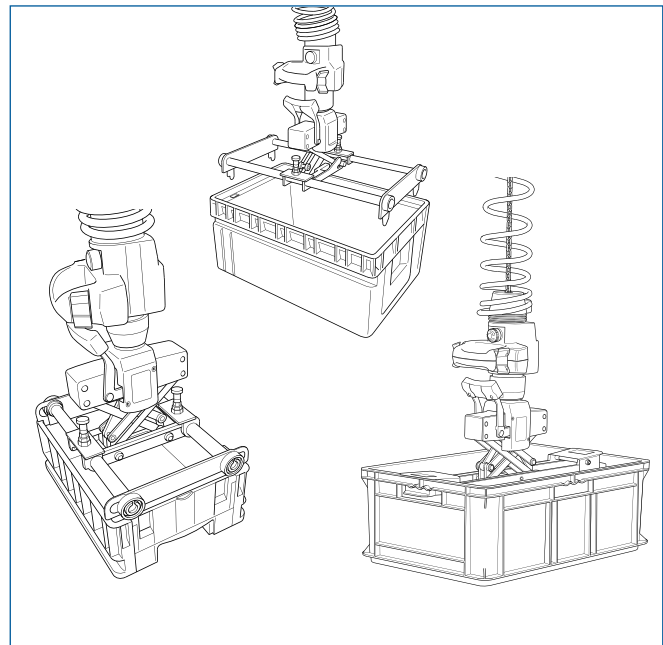
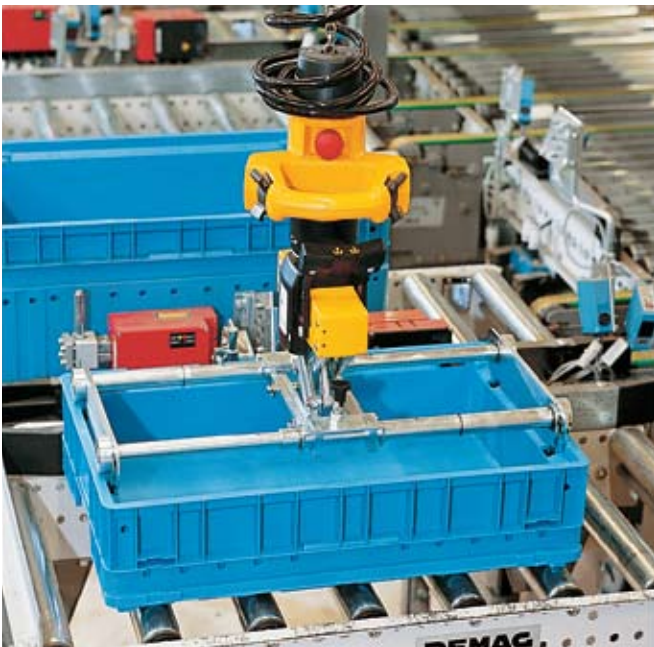

Grippers for various container types

Slewing jibs facilitate load handling at the workplace

Pillar- and wall-mounted slewing jibs along with the DC-Pro chain hoist provide cost effective support at the workplace and facilitate space-saving load handling in production, storage and shipping. When used direct on

production machinery, they help to cut set-up and idle time. Wall- and pillar-mounted slewing jibs cranes are suitable for virtually any application.

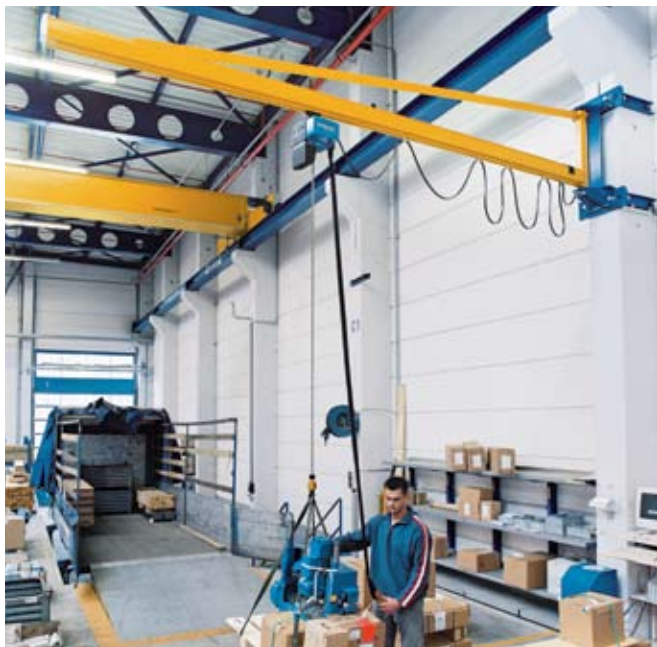

Wall-mounted slewing jibs

These cranes, which take up no floor space, can be used wherever load-bearing concrete walls or pillars are available. The slewing rotation up to 270° and the possibility to fit them to machinery and installations makes them ideal for a wide range of applications.



Pillar-mounted slewing jibs and cranes

The floor space serviced by these free-standing cranes is fully utilized thanks to their slewing range of up to 300°. They can be used for many applications. They can be erected indoors or outside and used for handling goods at loading ramps or for serving machinery. These cranes provide maximum hook paths even where only little headroom is available. The pillar has only a small footprint and is either anchored to the foundations using anchor rods or to an existing concrete floor using anchor bolts.

KBK slewing jibs feature struts and enclosed profile section of rail and offer a low deadweight for load capacities up to 2200 lb (1000 kg). Loads can be moved quite simply by hand.

See brochure 93007449 for further information on pillar and wall-mounted slewing jibs and cranes.



Efficient material flow with KBK monorail and crane installations

Interlinking production processes, serving machinery, moving materials – all handling and transport tasks have one thing in common: loads not only have to be lifted and lowered, but horizontal motions are also required.

The KBK crane construction kit is the ideal horizontal transport system for the DC-Pro and DCM-Pro Manulift. KBK installations are used for both linear and two dimensional load movement.

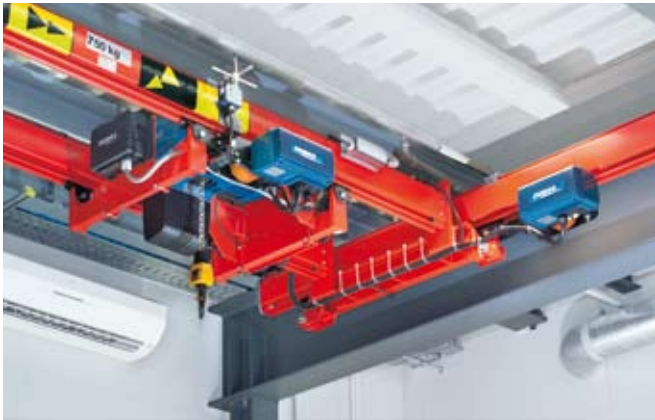

Suspension cranes

Single and double-girder suspension cranes are used for rectangular work area load handling. The low deadweight enables loads to be easily moved by hand. Travel drives are also available for precise positioning of larger loads.

Portal cranes

Portal cranes from the KBK system are mounted on castors and can be easily moved. When fitted with the DC-Pro chain hoist, this makes them ideal and flexible lifting devices, above all for repair and assembly work.

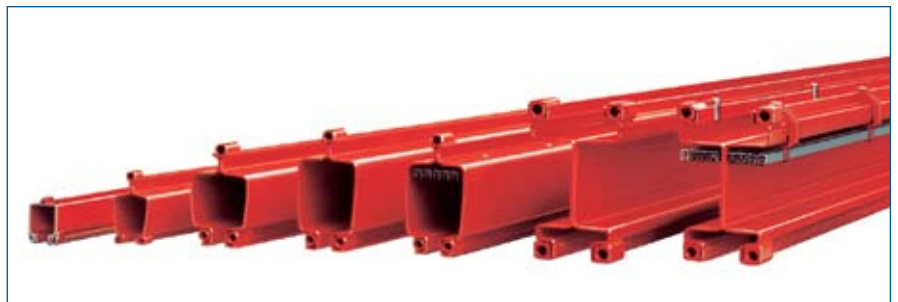

KBK sections are available in various sizes for different load capacities

Many components are available to create efficient overhead material handling solutions to meet specific application requirements.

The KBK crane construction kit is a suspension system which uses no valuable floor space and therefore leaves production area free. It is completely modular in design, all connections are bolted or fitted. This enables installations to be modified or extended easily and cost-effectively.



Suspension monorails

Suspension monorails are the preferred linear solution to connect pick-up and deposit loads. There are many possible designs from simple, manually controlled straight sections to complex, semi or fully automated closed-circuit monorail systems which enable a wide variety of applications to be implemented. Straight and curved sections, track switches and turntables facilitate flexible cost-effective solutions to the most diverse operating conditions.

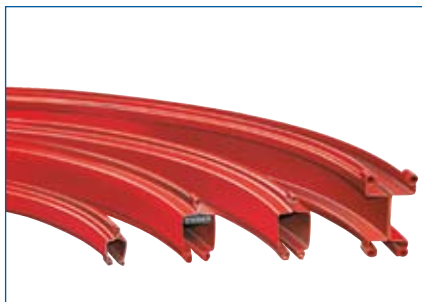

See brochure 93007249 for further information on track and crane systems from the KBK crane construction kit

KBK Aluline – aluminium profile sections

Manual-travel trolleys for simple horizontal movement

U Style Manual Trolley

The new U style manual trolley generation is available in four sizes for load capacities up to: 2425 lb (1100 kg) (U 11), 4850 lb (2200 kg) (U 22), 7500 lb (3400 kg) (U 34) and 12,125 lb (5600 kg) (U 56). The flange width can be infinitely adjusted by means of two adjusting rings and covers a range from 2.28 (58 mm) to 7.87 (200 mm), and 7.91 (201 mm) to 12.20 (310 mm). This facilitates fast and simple installation.

The travel rollers, which are made of high-strength and wear-resistant Polyamide, provides for smooth operation and low rolling resistance. Optional steel rollers are also available for special ambient conditions, e.g. high temperatures. The lateral steel guide rollers enable the curve-negotiating properties down to the



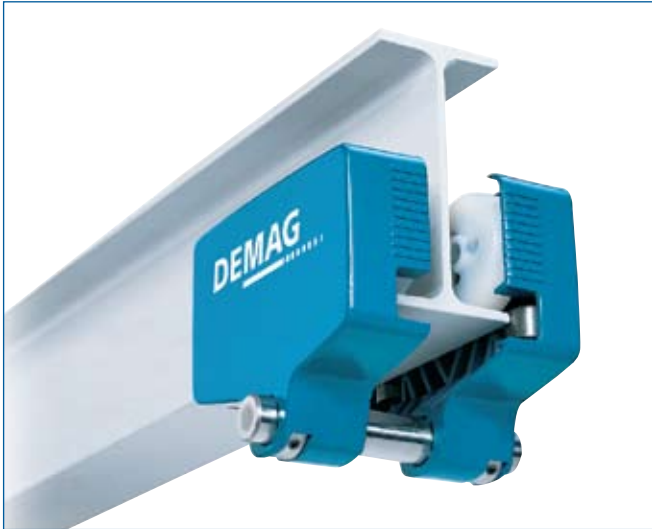

minimum radius of 3.28 (1000 mm) and minimize girder wear. Drop-stops are integrated into the aluminum die-cast, powder-coated side cheeks. The universal design of the travel rollers enables them to be used for operation on straight and sloping profile sections.

Manual-travel U style trolleys are designed for the simple addition of the E electric travel drive at a later date.



CF 5 click-fit trolley

Simply clicked onto the girder, curve-negotiating click-fit trolleys are ready for operation with a load capacity of up to 1200 lb (550 kg).

The flange widths from 2.28 to 3.58 (58 to 91 mm), the minimum curve radius of 31.50 (800 mm) and easy adaptability to standard section or parallel flange girders make them suitable for universal applications. The integrated drop-stop and lift-off protection provides for safe operation.

Plug & Drive with electric trolleys

E trolley

The E 11, E 22, E 34 and E 56 electric travel drives were specially developed for operation with the new DC-Pro chain hoist. This significantly extends the range of applications of this state-of-the-art hoist.

The same travel drives can be adapted to the U 11–U 34 trolleys. Particularly short approach dimensions can be achieved when the units are mounted in a vertical arrangement. Fast retro-fitting and commissioning offer further benefits as no changes need to be made to the manual-travel trolleys:



The drive is simply connected to the DC-Pro chain hoist using quick disconnect connectors and operated by means of the newly developed DSE 10-C control pendant. The control pendant for long and cross travel is simply fitted by means of a locking connector. The E 22 travel drive is used as standard for the KBK rail system with the new RF 125 friction wheel travel drive.

The E electric travel drive features a state-of-the-art, compact industrial design and offers outstanding travel characteristics. The control system integrated into the

travel unit provides for soft starting and braking for low-sway load handling. A convenient load-sway damping system can be activated for the cross-travel motion. The speeds and acceleration and braking rates can also be modified by means of the DSE-10 C control pendant, if required. All electrical connections are of plug-in design.

The trolleys can also be fitted with an optional cross-type limit switch, either with fast-to-slow and limit switch cut-off or only with limit switch cut-off.

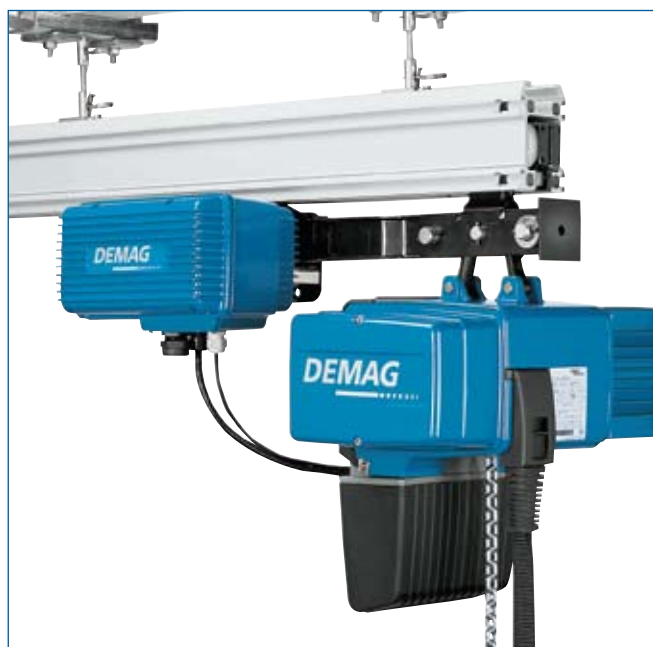

Clamp-fitted buffers to limit travel

KPA/KPT clamp-fitted buffers are the ideal solution to limit travel and are suitable for all DC-Pro trolleys. They can be fitted to sloping and parallel I-beam girders quickly and easily. The travel range is shortened or extended by simply relocating the buffers.

They can be adapted to flange widths from 1.97" to 11.81" (50 to 300 mm) for universal applications.

They are suitable temperature ranges from -4°F to +158°F (-20°C to + 70°C) as well as for operation outdoors thanks to adequate resistance to aging, ozone and weather conditions. Furthermore, they offer good resistance to acids and lyes. The tightening torque details are cast into the buffer to ease assembly.



Service – ready to help around the clock

All over the world

We offer you service around the clock with our world-wide network of Demag expert service teams and Demag partners. This ensures the highest availability and safety in your installation.



Service systems: Demag IDAPSY

We have developed a new integrated service system for the new Demag DC-Pro chain hoist: Demag IDAPSY. IDAPSY stands for **I**nspection **D**iagnosis **A**pplication **S**ystem.

And these are your benefits:

■ Service Recording

By recording utilization of the installation, Demag IDAPSY facilitates preventative maintenance. This assures a high level of reliability.

■ Analysis

Recorded data provides an excellent basis for analysis. Error messages can be called up for maintenance or repair purposes.

■ Efficiency

Maintenance work carried out during scheduled shutdowns to ensure your installation operates at optimal efficiency.

Demag IDAPSY enables service work to be carried out quickly. This means the diagnosis of the problem can be quickly identified and the hoist can be serviced and quickly put back in operation.

Your individual service package

Demag Service and our Demag partners offer a comprehensive portfolio of services to ensure the reliability of your installation throughout its entire lifecycle:

- Routine inspections according to relevant accident prevention regulations
- Inspection and maintenance
- Fault diagnosis
- Service training for operators and maintenance engineers



Selection criteria

The size of the hoist is determined by the load spectrum, average operating time per working day, capacity and reeving.

1. What are the operating conditions?
2. What is the specified safe working load?
3. To what height must the load be lifted?
4. What is the required lifting speed?
5. Do the loads need to be lifted and lowered with high precision?
6. Is horizontal load travel necessary?
7. How is the hoist to be controlled?

Load spectrum

The load spectrum (in most cases estimated) can be evaluated in accordance with the following definitions:

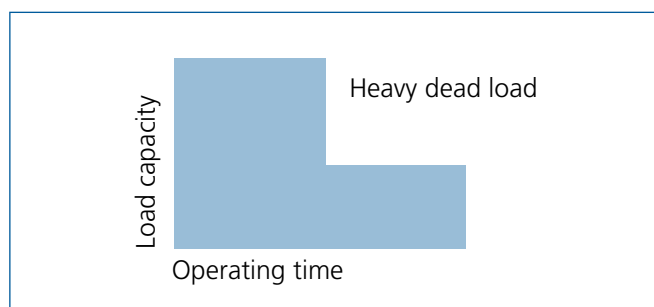
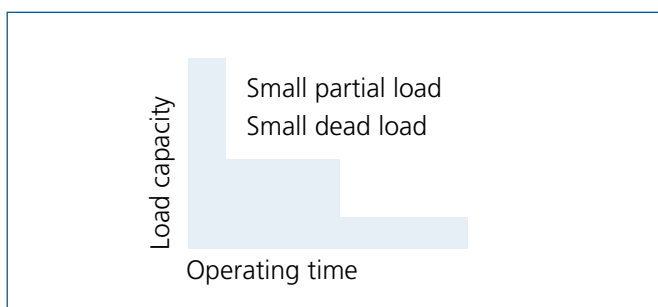

1 Light

Hoist units which are usually subject to very small loads and only in exceptional cases to maximum loads.

3 Heavy

Hoist units which are usually subject to medium loads but frequently to maximum loads.

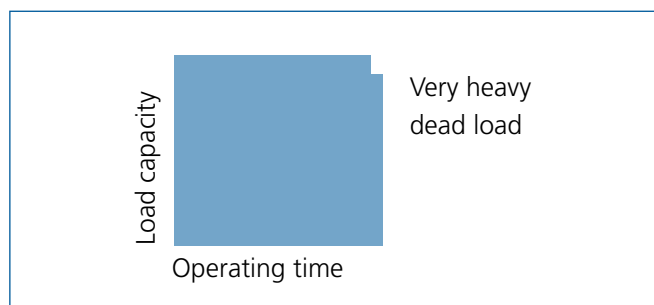
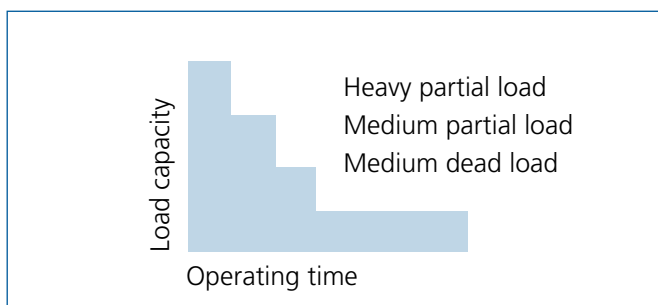

2 Medium

Hoist units which are usually subject to small loads but rather often to maximum loads.

4 Very heavy

Hoist units which are usually subject to maximum and almost maximum loads.

The group is determined by the load spectrum and operating time.

Load spectrum				Average operating time per day in hours			
L1	Light			2-4	4-8	8-16	over 16
L2	Medium			1-2	2-4	4-8	8-16
L3	Heavy			0.5-1	1-2	2-4	4-8
L4	Very heavy			0.25-0.5	0.5-1	1-2	2-4
Group of mechanisms to FEM				1Am	2m+	3m	4m

Reeving		Range		Size	
Capacity in lb (kg)					
1/1	2/1				
Demag DC chain hoist					
175 (80)		DC-Pro 1 / DC-Pro 2			175 (80)
220 (100)		DC-Pro 1 / DC-Pro 2			220 (100)
275 (125)		DC-Pro 1 / DC-Pro 2			275 (125)
350 (160)		DC-Pro 2			350 (160)
350 (160)		DC-Pro 5			350 (160)
440 (200)		DC-Pro 2			440 (200)
440 (200)		DC-Pro 5			440 (200)
550 (250)		DC-Pro 2		550 (250)	550 (250)
555 (252)		DC-Pro 5			550 (250)
695 (315)		DC-Pro 5			695 (315)
695 (315)		DC-Pro 10			695 (315)
880 (400)		DC-Pro 5			880 (400)
880 (400)		DC-Pro 10			880 (400)
1100 (500)		DC-Pro 5		1100 (500)	1100 (500)
1100 (500)		DC-Pro 10			1100 (500)
1390 (630)		DC-Pro 10			1390 (630)
1760 (800)		DC-Pro 10			1760 (800)
2200 (1000)		DC-Pro 10		2200 (1000)	2200 (1000)
2750 (1250)		DC-Pro 10		2750 (1250)	2750 (1250)
2750 (1250)		DC-Pro 16			2750 (1250)
	2750 (1250)	DC-Pro 10			2750 (1250)
3500 (1600)		DC-Pro 16		3500 (1600)	3500 (1600)
	3500 (1600)	DC-Pro 10			3500 (1600)
4400 (2000)		DC-Pro 25		4400 (2000)	4400 (2000)
	4400 (2000)	DC-Pro 10			4400 (2000)
5500 (2500)		DC-Pro 25		5500 (2500)	5500 (2500)
	5500 (2500)	DC-Pro 10			5500 (2500)
	7000 (3200)	DC-Pro 16			7000 (3200)
	8800 (4000)	DC-Pro 25			8800 (4000)
	11000 (5000)	DC-Pro 25		11000 (5000)	11000 (5000)

Example:

- Capacity 250 kg
- Load spectrum "medium" from table
- Lifting speed 8 m/min;
- 1/1 reeving
- Average hook path 4 m;
- Number of cycles/hour 20
- Working time/day 8 hours

The average operating time per working day is estimated or calculated as follows:

$$\begin{aligned} \text{Operating time/day} &= \frac{2 \cdot \text{average hook path} \cdot \text{no. of cycles/h} \cdot \text{working time/day}}{60 \cdot \text{speed hoist}} \\ &= \frac{2 \cdot 4 \cdot 20 \cdot 8}{60 \cdot 8} = 2.66 \text{ hours} \end{aligned}$$

For the medium load spectrum and an average daily operating time of 2.66 hours, the table shows group 2m+. For a load capacity of 250 kg, the diagram shows size DC-Pro 2-250.

Technical data

Model code

EU	DC-Pro	10 -	2000	2/1	H5	V6/1,5	380 - 415 /	60	24/6	100
										Flange width [mm] or I beam
										Travel speed [m/min]
										Frequency [Hz]
										Voltage range chain hoist [V]
										Hoist speed [m/min]
										Hook path [m]
										Reeving
										Load capacity [kg]
										Size
	DC	Demag chain hoist								
	Trolley type									
CF	Click-fit trolley		E		Electric travel drive					
U	Travelling hoist		D		Articulated trolley					
R	Push travel									

Demag DCM-Pro Manulift selection table

Capacity lb [kg]	Manulift Type	Hoist speed		Motor size	Lift ft [m]	Group of mechanisms FEM	Reeving	Max. weight for 2,8 and 4,3 hook path lb [kg]
		ft/min at 60 Hz	m/min at 60 Hz					
275 (125)	DCM-Pro 1 - ...	32/8	(9.6/2.4)	ZNK 71 B 8/2	9 (2.8) and 14 (4.3)	4m	1/1	49/51 (22 / 23)
	DCM-Pro 2 - ...	64/16	(19.2/4.8)			2m+ ¹⁾		
550 (250)	DCM-Pro 2 - ...	32/8	(9.6/2.4)	ZNK 80 B 8/2	14 (4.3)	4m		62/64 (28/29)
	DCM-Pro 5 - ...	64/16	(19.2/4.8)					

1) 2m+ corresponds to 1900 hours at full load

Demag DCM-Pro Manulift dimension table

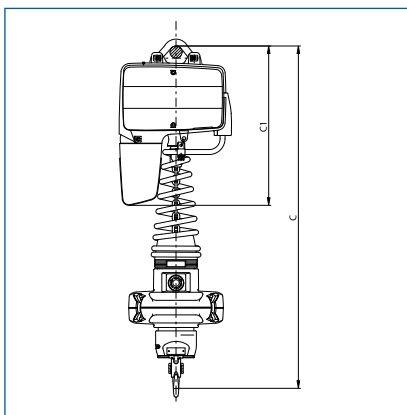

Size	Short suspension bracket			Long suspension bracket		
	C in(mm)		C1 in(mm)	C in(mm)		C1 in(mm)
	for hook path		Chain collector box	for hook path		Chain collector box
	9 ft (2.8m)	14 ft (4.3m)	H5	9 ft (2.8m)	14 ft (4.3m)	H5
DCM-Pro 1	25.60 (635)	27.76 (705)	13.19 (335)	26.50 (673)	29.25 (743)	14.69 (373)
DCM-Pro 2	25.60 (635)	27.76 (705)	13.19 (335)	26.50 (673)	29.25 (743)	14.69 (373)
DCM-Pro 5	26.77 (680)	29.53 (750)	15.55 (395)	28.27 (718)	31.02 (788)	17.13 (435)

DC-Pro chain hoist selection table

Capacity lb [kg]	Chain hoist		Motor size	Hook path ²⁾ ft [m]	Group of mechanisms FEM	Reeving	Max. weight at H5 / H8 respect. H4 lb [kg]		
	Type	ft/min at 60 Hz [m/min at 60 Hz]							
275 (125)	DC-Pro 1 -...	32/8 (9.6/2.4)	ZNK 71 B 8/2	16 & 26 (5 & 8)	4m	1/1	49/53 (22/24)		
	DC-Pro 2 -...	64/16 (19.2/4.8)							
550 (250)	DC-Pro 2 -...	32/8 (9.6/2.4)	ZNK 71 B 8/2		2m+ ¹⁾		49/53 (22/24)		
	DC-Pro 5 -...	64/16 (19.2/4.8)	ZNK 80 A 8/2		4m		62/66 (28/30)		
1100 (500)	DC-Pro 5 -...	32/8 (9.6/2.4)	ZNK 80 A 8/2		2m+ ¹⁾		62/66 (28/30)		
	DC-Pro 10 -...	48/12 (14.4/3.6)	ZNK 100 A 8/2		4m		106/115 (48/52)		
2200 (1000)	DC-Pro 10 -...	24/6 (7.2/1.8)	ZNK 100 A 8/2		2m+ ¹⁾		106/115 (48/52)		
		48/12 (14.4/3.6)	ZNK 100 B 8/2				124/133 (56/60)		
4400 (2000)	DC-Pro 10 -...	24/6 (7.2/1.8)	ZNK 100 B 8/2		16 & 26 (5 & 8)		2m+ ¹⁾	2/1	144/161 (65/73)
	DC-Pro 25 -...	32/8 (9.6/2.4)	ZNK 100 C 8/2					13 (4)	1/1
5500 (2500)	DC-Pro 10 -...	16/4 (4.8/1.2)	ZNK 100 B 8/2	16 & 26 (5 & 8)	1Am	2/1	144/161 (65/73)		
	DC-Pro 25 -...	32/8 (9.6/2.4)	ZNK 100 C 8/2			13 (4)	1/1	250 (113)	
7000 (3200)	DC-Pro 16 -...	16/4 (4.8/1.2)	ZNK 100 B 8/2	13 (4)	2m+ ¹⁾	2/1	243 (110)		
		24/6 (7.2/1.8)	ZNK 100 C 8/2						
8800 (4000)	DC-Pro 25 -...	16/4 (4.8/1.2)		13 (4)	2m+ ¹⁾	2/1	276 (125)		
11000 (5000)					1Am				

1) 2m+ corresponds to 1900 hours at full load 2) Longer hook paths possible, please consult Demag

Demag DC-Pro chain hoist dimension tables

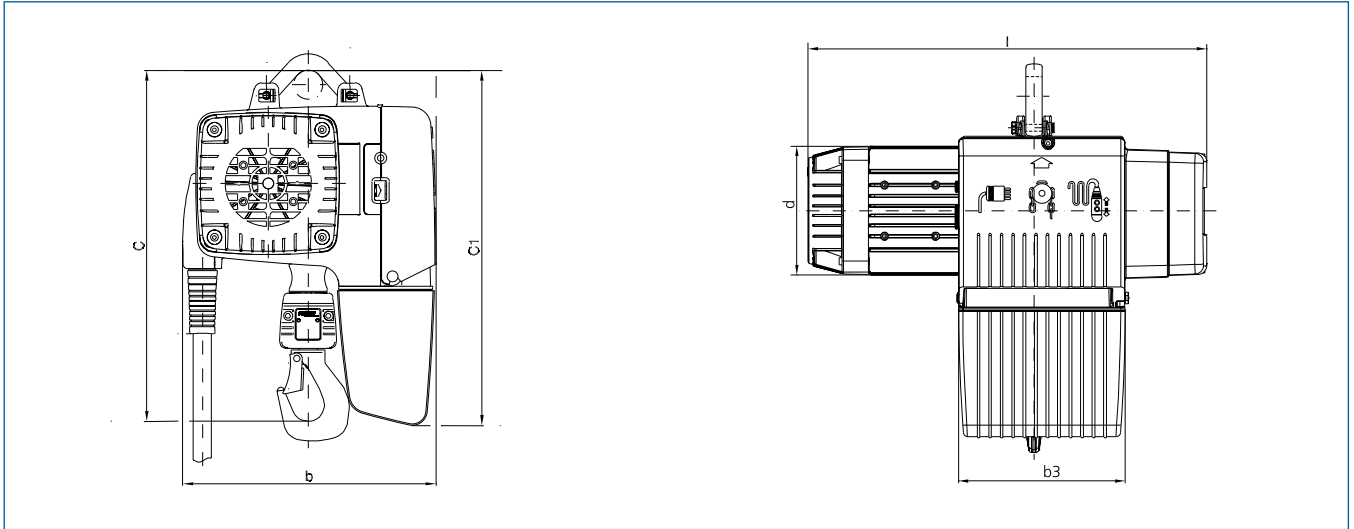

DC-Pro 1–10, up to 2200 lb (1000 kg) 1/1 reeving

Size	Motor	Suspension Bracket						b in(mm)	l in(mm)	b3 in(mm)	d in(mm)
		short	long	short		long					
		C in(mm)		Chain collector box size							
				H5	H8	H5	H8				
		C 1 in(mm)									
DC-Pro 1	ZNK 71 B 8/2	12.83	14.33	13.19	14.37	14.69	15.87	10.55	16.61	7.20	4.88
DC-Pro 2		(326)	(364)	(335)	(365)	(373)	(403)	(268)	(422)	(183)	(124)
DC-Pro 5	ZNK 80 B 8/2	14.88	12.44	15.55	16.73	17.13	18.31	11.02	18.43	7.68	5.94
		(378)	(316)	(395)	(425)	(435)	(465)	(280)	(468)	(195)	(151)
DC-Pro 10	ZNK 100 A 8/2	18.58	19.88	19.41	22.91	20.71	24.21	13.74	20.79	8.94	7.36
		(472)	(505)	(493)	(582)	(526)	(615)	(349)	(528)	(227)	(187)
DC-Pro 10	ZNK 100 B 8/2	18.58	19.88	22.91	22.91	24.21	24.21	13.74	22.76	8.94	7.36
		(472)	(505)	(582)	(582)	(615)	(615)	(349)	(578)	(227)	(187)

DC-Pro 10, 2750 to 5500 lb (1250 to 2500 kg) 2/1 reeving

Size	Motor	Suspension bracket						H5	H8	H5	H8	l in(mm)	d in(mm)
		short	long	short		long							
		C in(mm)		Chain collector box size									
				H5	H8	H5	H8						
		C 1 in(mm)				b in(mm)		b3 in(mm)					
DC-Pro 10	ZNK 100 B 8/2	21.30	22.60	22.91	22.91	24.21	24.21	134.74	16.10	8.94	12.99	22.76	7.36
		(541)	(574)	(582)	(582)	(615)	(615)	(349)	(409)	(227)	(330)	(578)	(187)

Demag DC-Pro chain hoist dimension tables

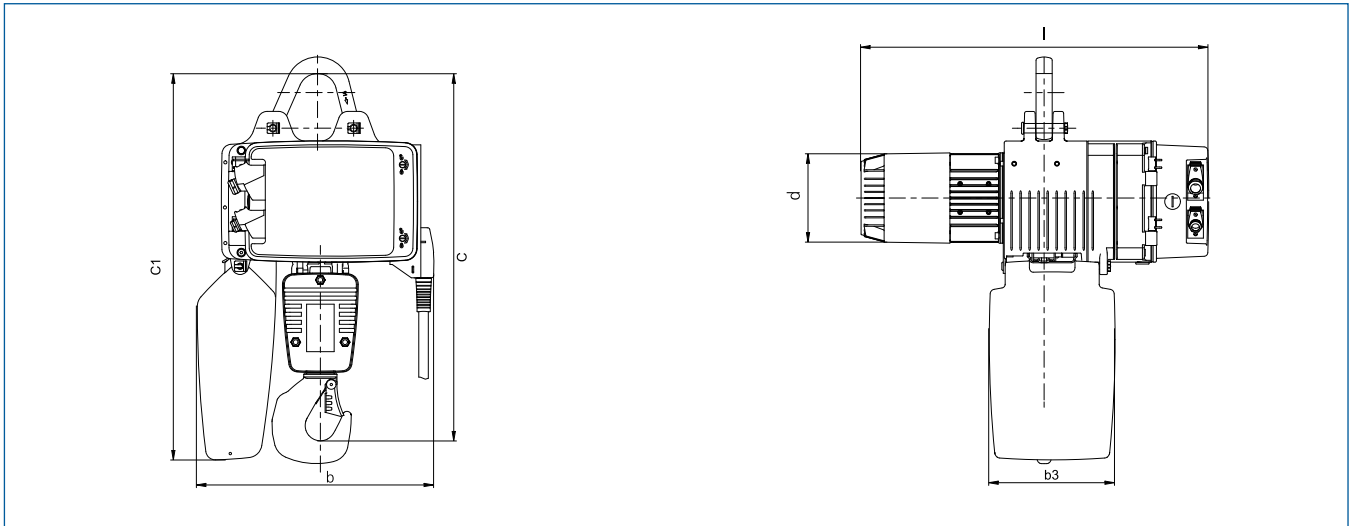

DC-Pro 16–25, 2750 to 5500 lb (1250 to 2500 kg)

Reeving 1/1

Size	Motor	C in(mm)	Chain collector box size						I in(mm)	Chain collector box size		d in(mm)
			Size 1	Hook path	Size 2	Hook path	Size 1	Size 2		Size 1	Size 2	
			C 1 in(mm)			b in(mm)				b3 in(mm)		
DC-Pro 16	ZNK 100 B 8/2	25.20 (640)	32.01 (813)	H14	35.16 (893)	H30	19.29 (490)	19.72 (501)	26.73 (679)	10.43 (265)	12.80 (325)	7.36 (187)
DC-Pro 25	ZNK 100 C 8/2	25.20 (640)	32.01 (813)	H10	35.16 (893)	H20	19.29 (490)	19.72 (501)	28.82 (732)	10.43 (265)	12.80 (325)	7.36 (187)

DC-Pro 16–25, 5500 to 11000 lb (2500 to 5000 kg)

Reeving 2/1

Size	Motor	C in(mm)	Chain collector box size						I in(mm)	Chain collector box size		d in(mm)
			Size 1	Hook path	Size 2	Hook path	Size 1	Size 2		H5	H8	
			C 1 in(mm)			b in(mm)				b3 in(mm)		
DC-Pro 16	ZNK 100 B 8/2	28.94	32.01	H7	35.16	H15	19.29	19.72	26.73 (679)	10.43	12.80	7.36 (187)
	ZNK 100 C 8/2	(735)	(813)		(893)		(490)	(501)	28.82 (732)	(265)	(325)	
DC-Pro 25	ZNK 100 C 8/2	30.31 (770)	32.01 (813)	H5	35.16 (893)	H10	19.29 (490)	19.72 (501)	28.82 (732)	10.43 (265)	12.80 (325)	7.36 (187)

DC-Pro chain hoist with CF 5 trolley dimension table

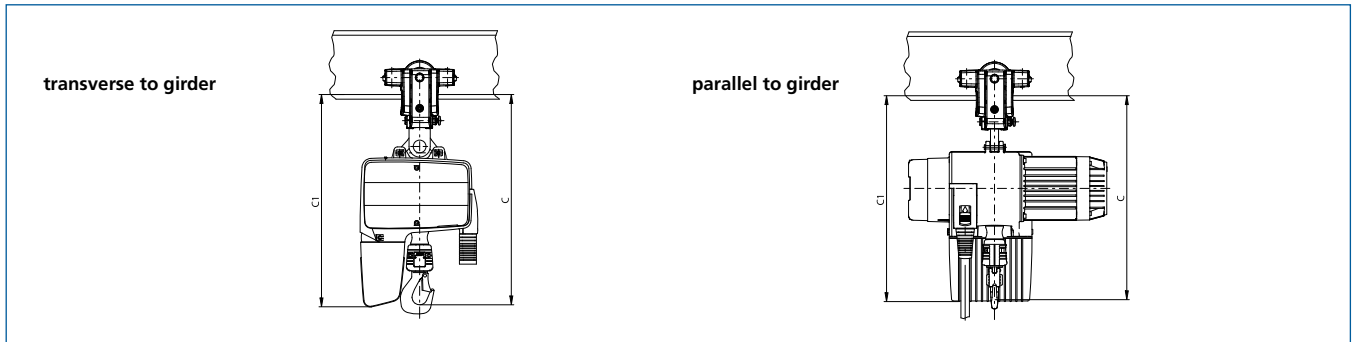

Size	transverse to girder			parallel to girder		
	C in(mm)	C1 in(mm) Chain collector box		C in(mm)	C1 in(mm) Chain collector box	
		H5	H8		H5	H8
DC-Pro 1	15.16 (385)	16.34 (415)	17.51 (445)	14.96 (380)	16.14 (410)	17.32 (440)
DC-Pro 2	15.16 (385)	16.34 (415)	17.51 (445)	14.96 (380)	16.14 (410)	17.32 (440)
DC-Pro 5	16.93 (430)	18.78 (477)	19.96 (507)	16.73 (425)	18.58 (472)	19.16 (502)

Dimension table for DC-Pro 1–10 chain hoists with U 11, U 22 or U 34 trolleys

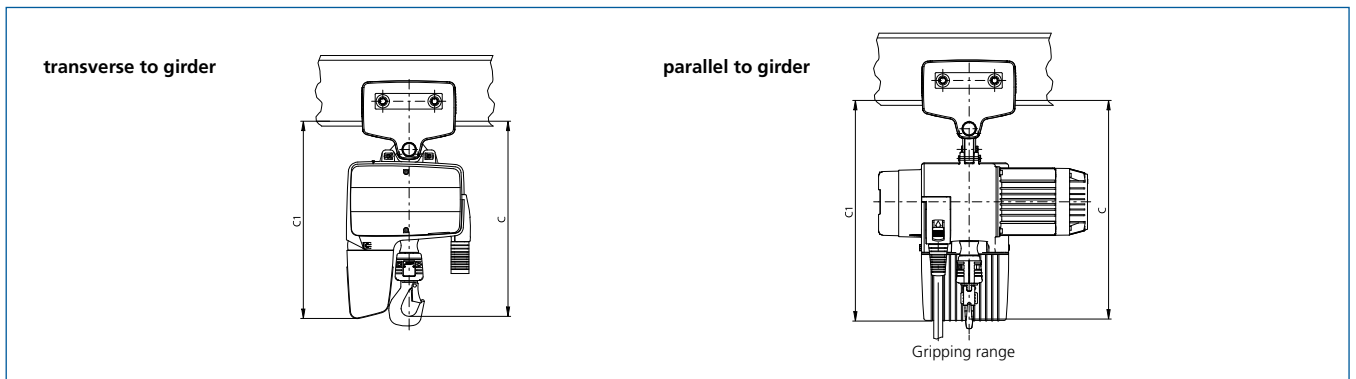

Size	Reeving	Trolley	transverse to girder			parallel to girder		
			C in(mm)	C1 in(mm) Chain collector box		C in(mm)	C1 in(mm) Chain collector box	
				H5	H8		H5	H8
DC-Pro 1	1/1	U 11	14.88 (378)	15.35 (390)	16.54 (420)	16.38 (416)	16.34 (415)	17.52 (445)
DC-Pro 2	1/1	U 11	14.88 (378)	15.35 (390)	16.54 (420)	16.38 (416)	16.34 (415)	17.52 (445)
DC-Pro 5	1/1	U 11	16.93 (430)	17.80 (452)	18.98 (482)	18.43 (468)	18.78 (477)	19.96 (507)
DC-Pro 10	1/1	U 11	20.63 (524)	22.76 (578)	26.26 (667)	21.93 (557)	23.70 (602)	27.20 (691)
	1/2	U 22 / 34	23.82 (605)	26.73 (679)	30.67 (779)	25.12 (638)	27.68 (703)	31.61 (803)

For further information, see U 11/U 22/U 34 technical data 203 570 44.

Dimension table for DC-Pro 16 and 25 chain hoists with U 22, U 34, RU 56 trolleys

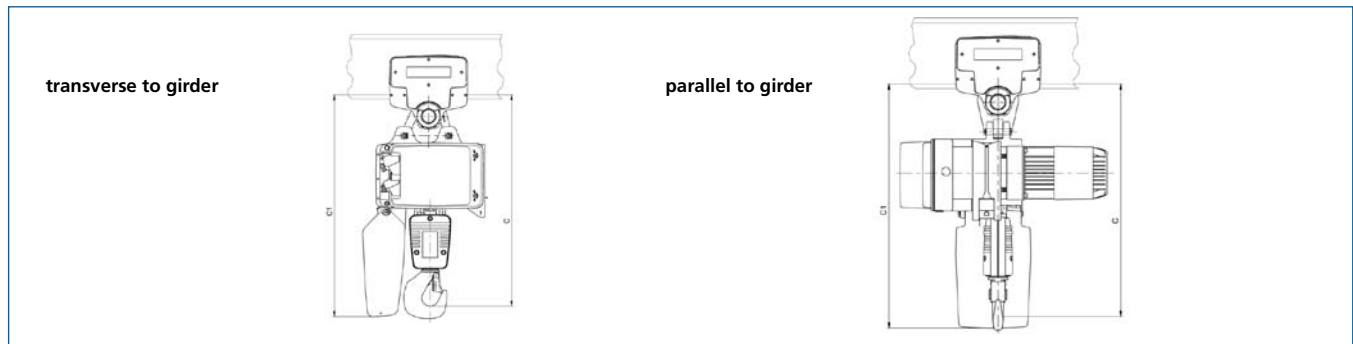

Size	Reeving	Trolley	transverse to girder			parallel to girder		
			C in(mm)	C1 in(mm)		C in(mm)	C1 in(mm)	
				Chain collector box			Chain collector box	
			H5	H8		H5	H8	
DC-Pro 16	1/1	U 22	27.72 (704)	34.53 (877)	37.68 (957)	28.98 (736)	35.79 (909)	38.94 (989)
	2/1	U 34	31.46 (799)	34.53 (877)	37.68 (957)	32.72 (831)	35.79 (909)	38.94 (989)
DC-Pro 25	1/1	U 34	27.72 (704)	34.53 (877)	37.68 (957)	28.98 (736)	35.79 (909)	38.94 (989)
	2/1	RU 56	33.46 (850)	35.16 (893)	38.31 (973)	34.72 (882)	36.42 (925)	39.57 (1005)

Trolley curve radii

Trolley size		Capacity lb[kg]	Runway girder			
			Push travel		Electric travel	
			Flange width in[mm]	Rmin ft[mm]	Flange width in[mm]	Rmin ft[mm]
CF 5		1200 (550)	1.97-3.58 (50-91)	2.62 (800)	-	-
U 11 DC	EU 11 DC	2425 (1100)	2.28-12.20 (58-310)	3.28 (1000)	2.28-12.20 (58-310)	6.56 (2000)
U 22 DC	EU 22 DC	4850 (2200)	3.23-12.20 (82-310)	6.56 (2000)	3.23-12.20 (82-310)	9.84 (3000)
U 34 DC	EU 34 DC	7500 (3400)	3.23-12.20 (82-310)	6.56 (2000)	3.23-12.20 (82-310)	9.84 (3000)
RU 56 DC	EU 56 DC	12350 (5600)	3.05-12.20 (98-310)	6.56 (2000) ¹⁾	3.05-12.20 (98-310)	8.20 (2500) ¹⁾

1) From flange width 4.17 (106 mm)

The specified curve radii apply for normal applications.
Please consult Demag for frequent curve travel (e.g. in automatic installations).

Travel speeds

Capacity lb[kg]	Chain hoist Typ	Reeving	Possible cross-travel speeds in approx. ... ft/min [m/min]							
			V 46/10 [14/3]		V 40/13 [12/4]		V 80/20 [24/6]		V 130/33 [40/10]	
			Trolley	Travel drive	Trolley	Travel drive	Trolley	Travel drive	Trolley	Travel drive
175 (80) to 2200 (1000)	DC-Pro 1 -... to DC-Pro 10 -...	1/1			-	-	U 11 DC	E 11 DC	-	-
2750 (1250)	DC-Pro 10 -...	2/1	-	-	RU 56 DC	ZBF 80 A 12/4	U 22 DC	E 22 DC	RU 56 DC	ZBF 80 A 8/2
	DC-Pro 16 -...	1/1					U 22 DC	E 22 DC		
3500 (1600)	DC-Pro 10 -...	2/1	-	-	RU 56 DC	ZBF 80 A 12/4	U 22 DC	E 22 DC	RU 56 DC	ZBF 80 A 8/2
	DC-Pro 16 -...	1/1					U 22 DC	E 22 DC		
4400 (2000)	DC-Pro 10 -...	2/1	-	-	-	-	U 22 DC	E 22 DC	-	-
	DC-Pro 25 -...	1/1	U 34 DC	E 34 DC	RU 56 DC	ZBF 80 A 12/4	RU 56 DC	ZBF 71 A 8/2	RU 56 DC	ZBF 80 A 8/2
5500 (2500)	DC-Pro 10 -...	2/1	U 34 DC	E 34 DC	-	-	-	-	-	-
	DC-Pro 25 -...	1/1			RU 56 DC	ZBF 80 A 12/4	RU 56 DC	ZBF 71 A 8/2	RU 56 DC	ZBF 80 A 8/2
7000 (3200)	DC-Pro 16 -...	2/1	U 34 DC	E 34 DC	RU 56 DC	ZBF 80 A 12/4	RU 56 DC	ZBF 71 A 8/2	RU 56 DC	ZBF 80 A 8/2
8800 (4000) 11000 (5000)	DC-Pro 25 -...		-	-	RU 56 DC	ZBF 80 A 12/4	RU 56 DC	ZBF 80 A 8/2	RU 56 DC	ZBF 90 B 8/2

E 11/E 22/E34 travel drive selection table, 220–480 V, 50/60 Hz, 3 ~

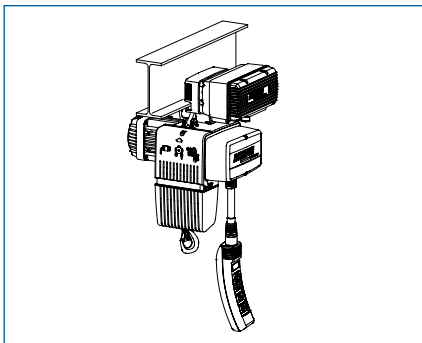

max. displaceable weight incl. dead weight ²⁾ lb[kg]	Travel drive Typ	Speed at		Possible trolleys	Max. weight lb[kg]
		full load ³⁾ ft/min [m/min]	partial load ¹⁾ ft/min [m/min]		
2425 (1100)	E 11	80/20 (24/6)	100 (30)	U 11	9 (4)
4850 (2200)	E 22			U 22, RF 125	12 (5)
7500 (3400)	E 34	48/12 (14/3.5)	-	U 34	12 (5)

1) Possible by programming other parameters 2) Max. 1% climbing ability 3) infinitely variable up to 80 ft/min (24m/min)

See operating instructions 214 810 44 for further information.

E 22 trolley on KBK RF 125 dimensions

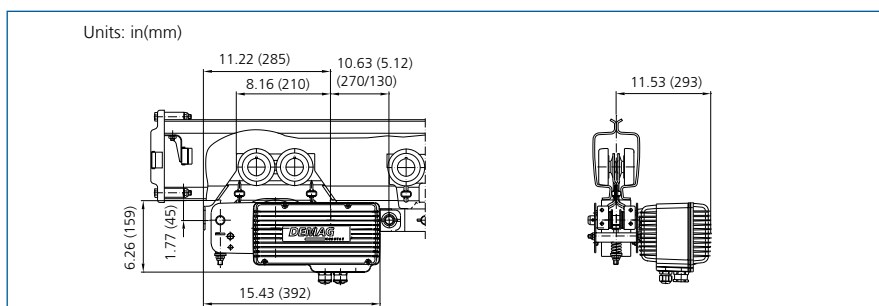

E 11/E 22/E 34 travel drive on U 11/U 22/U 34 trolley dimensions

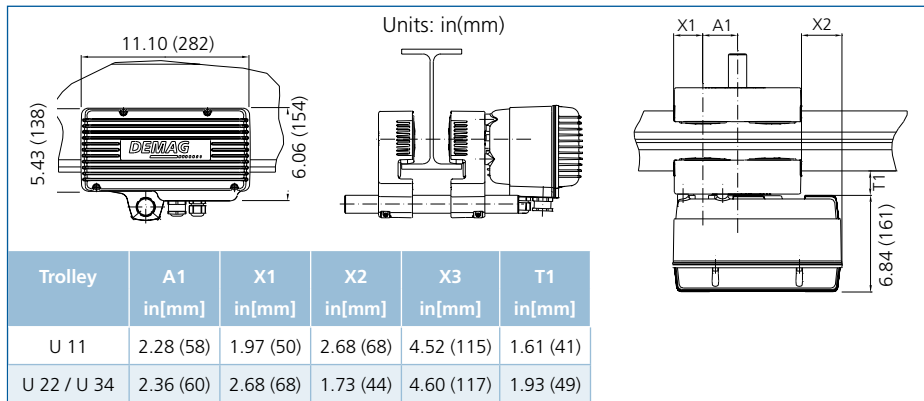

Pantograph tongs for load capacity up to 275 lb (125 kg) dimension table

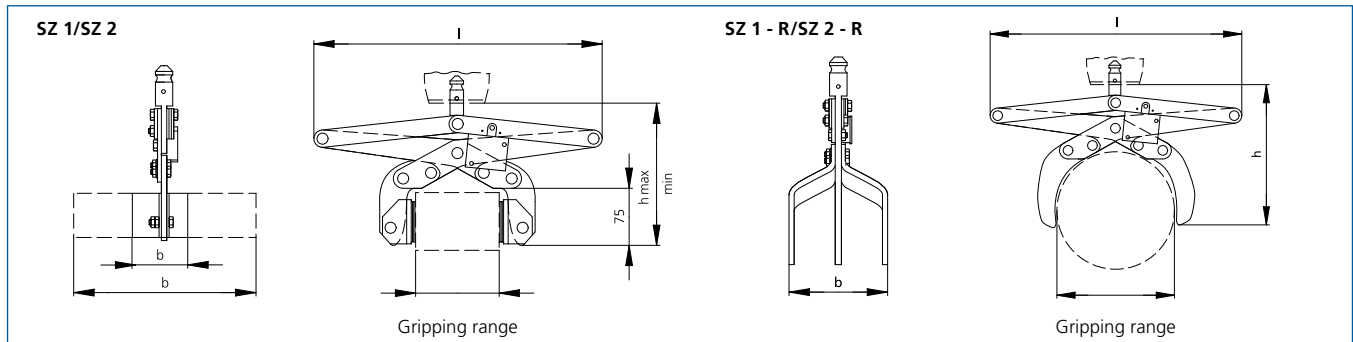

Range	Gripping range	b in(mm)	l in(mm)	h min in(mm)	h max in(mm)	Size	Part-no.:	Weight in kg
SZ 1	2.36-3.15 (60-80)	2.36 (60)	14.57 (370)	7.48 (190)	10.43 (265)	SZ 1-08-1	265 701 44	7.72 (3.5)
	3.15-4.13 (80-105)					SZ 1-10-1	565 601 44	
	4.13-5.12 (105-130)					SZ 1-13-1	565 702 44	
	5.12-6.10 (130-155)	2.36 (60)	14.57 (370)	7.48 (190)	10.43 (265)	SZ 1-15-1	565 602 44	8.16 (3.7)
	6.10-7.09 (155-180)					SZ 1-18-1	565 703 44	
	7.09-8.07 (180-205)					SZ 1-20-1	565 603 44	
	2.36-3.15 (60-80)	7.87 (200)	14.57 (370)	7.48 (190)	10.43 (265)	SZ 1-08-2	565 704 44	9.48 (4.3)
	3.15-4.13 (80-105)					SZ 1-10-2	565 604 44	
	4.13-5.12 (105-130)					SZ 1-13-2	565 705 44	
	5.12-6.10 (130-155)	7.87 (200)	14.57 (370)	7.48 (190)	10.43 (265)	SZ 1-15-2	565 605 44	9.92 (4.5)
	6.10-7.09 (155-180)					SZ 1-18-2	565 706 44	
	7.09-8.07 (180-205)					SZ 1-20-2	565 606 44	
1.57-5.91 (40-150)	4.72 (120)	14.57 (370)	8.86 (225)	16.54 (420)	SZ 1-R-15	565 608 44	8.82 (4.0)	
SZ 2	5.51-8.27 (140-210)	2.36 (60)	20.47 (520)	7.48 (190)	16.34 (415)	SZ 2-21-1	565 712 44	10.36 (4.7)
	8.27-10.83 (210-275)					SZ 2-27-1	565 612 44	
	10.83-13.39 (275-340)					SZ 2-34-1	565 613 44	
	5.51-8.27 (140-210)	7.87 (200)	20.47 (520)	7.48 (190)	16.34 (415)	SZ 2-21-2	565 715 44	11.91 (5.0)
	8.27-10.83 (210-275)					SZ 2-27-2	565 615 44	
	10.83-13.39 (275-340)					SZ 2-34-2	565 616 44	
	3.94-11.81 (100-300)	6.30 (160)	20.47 (520)	2.80 (325)	24.41 (620)	SZ 2-R-30	565 618 44	11.69 (5.3)

Find your hoist

www.demag-hoistdesigner.com is the website address where all important data and facts on the new Demag DC-Pro chain hoist and Manulift DCM-Pro can be found.

This information and planning platform provides you with a comprehensive product overview and contains all the data you need for project engineering. You can also download the CAD drawings of the entire Demag chain hoist range and integrate them into your design drawings.

Suitable hoists and accessories can be selected in this way. A practical and intuitive user interface ensures that you find the right solution to meet your needs quickly and easily.

The Demag Internet order system at **www.demag-shop.com** also makes it possible to order chain hoists and components immediately.

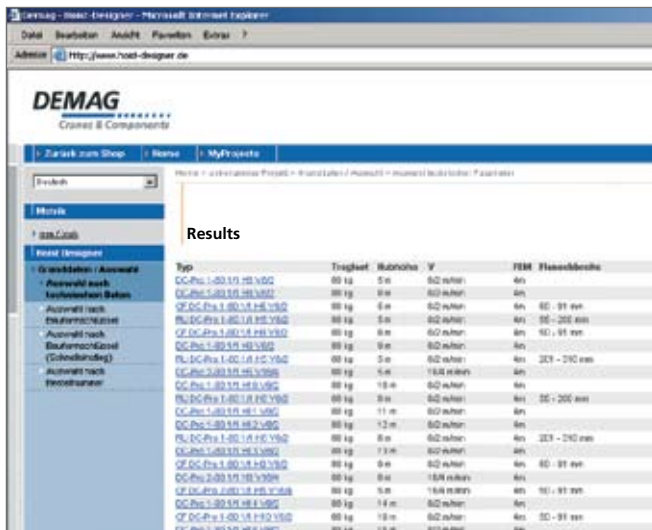
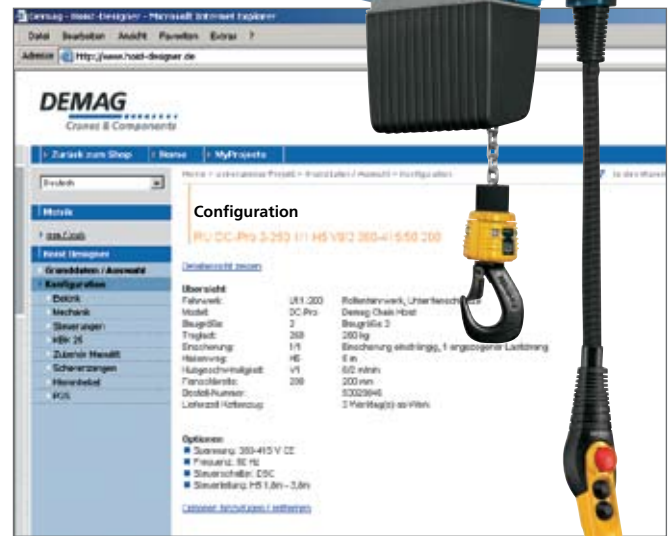
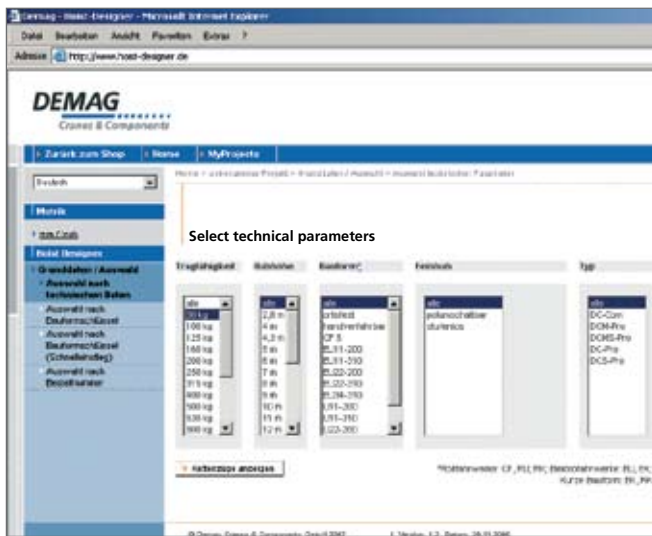

DEMAG

Cranes & Components

California 5435 Industrial Parkway • San Bernardino, California 92407
Telephone (909) 880-8800 • Fax (909) 880-4469

Georgia 254 Lake Ruby Drive • Suwanee, Georgia 30024
Telephone (678) 546-0593 • Fax (678) 482-7653

Illinois 11261 Kiley Drive • Huntley, Illinois 60142
Telephone (847) 515-7030 • Fax (847) 515-7040

Michigan 46545 Continental Drive • Chesterfield, Michigan 48047
Telephone (586) 949-6035 • Fax (586) 949-6038

Missouri 3375 Hwy 185 • Washington, Missouri 63090
Telephone (636) 390-2495 • Fax (636) 390-0366

South Carolina BTC 560, Suite 150, 454 S. Anderson Road • Rock Hill, SC 29730
Telephone (803) 909-9000 • Fax (803) 909-9001

Ohio 29201 Aurora Road • Cleveland, Ohio 44139
Telephone (440) 248-2400 • Fax (440) 248-3874

Ontario 1155 North Service Road West, Unit 1 • Oakville, Ontario L6M 3E3
Telephone (905) 825-5900 • Fax (905) 825-5901

Quebec 3524, Rue Ashby • St-Laurent, Quebec H4R2C1
Telephone (514) 336-5556 • Fax (514) 336-4349

Texas 16430 Aldine-Westfield Road • Houston, Texas 77032
Telephone (281) 443-7331 • Fax (281) 443-7308

Washington 704 - 228th Avenue NE • Sammamish, Washington 98074
Telephone (425) 883-4668 • Fax (425) 883-4828

Demag Cranes & Components Corp.

29201 Aurora Road
Cleveland, Ohio 44139
Telephone (440) 248-2400
Fax (440) 248-3874
www.demag-us.com