





Demag wheel range

Reliable series-produced components for travel units with wheel loads up to 132,200 lbs (60 t)



Demag wheel systems – the right solution for every application



Contents	Page
 Demag DRS wheel block system	6
 Demag LRS travel wheel system	14
 Demag RS wheel block system	16
 Demag DWS wheel set	18

For decades, we have been designing and manufacturing modular wheel systems for a wide variety of applications. The broad range covers wheel loads up to 132,000 lbs (60 t) and offers:

- simple selection
- many combinations
- compact dimensions
- versatile connection to the customer’s design
- design support by CAD files
- simple assembly and alignment

Demag wheel units are integral components of many drive solutions that are in operation every day, offering high reliability and a long service life with a minimum maintenance requirement.



Complete travel units

Complete travel units provide decisive advantages for drive applications. All components are perfectly matched and pre-assembled ready for fitting – from the travel wheel, housing and connecting arrangement to the gearbox, motor and frequency inverters for electronically controlled travel. Complete travel units give you the certainty of solid planning and a reliable investment.

Solutions for specific industries

There is hardly a manufacturing industry in which raw materials, semi-finished and finished products do not have to be transported, merged, transferred, distributed or assembled. In many applications, special operating conditions and functional requirements have to be taken into consideration.

Demag wheel systems meet the demands of any application, making them the first choice for any materials handling situation.

If required, wheel blocks can be protected, for example, by special design measures against aggressive media. Or they can be fitted with electronically controlled drives, which enable them to accelerate even more quickly, travel at uniform speeds and position with precision.

Demag wheel systems ensure that floor-level travel units and systems can also negotiate tight curves with radii down to 30 ft (10 m), operating just as well indoors as outdoors.

Comprehensive application expertise

We leverage our extensive experience with installing wheel block systems worldwide to help ensure customer success and world-class performance. We offer state-of-the-art selection and design tools as well as calculation programs and project engineering support for the given application requirements.

Global presence

Wherever your Demag products are used, our service partners guarantee a reliable supply of spare parts and provide expert repairs.

Always the right wheel – for standardized and specific applications

Demag travel components are designed to match perfectly from start to finish, enabling fast and cost-effective standardized and tailored modular solutions to be implemented to meet your individual requirements. Every component used is developed, designed and tested by our specialists for unbeatable functional reliability, continuously optimized and manufactured in large series of first-class quality and with maximum precision.



DRS

The DRS wheel block system

This versatile system provides optimum performance ratios for a maximum load capacity (from 6,000 to 88,100 lbs / 2.75 to 40 t) with compact dimensions. Finely graded sizes (DRS 112 to DRS 500) ensure that the right unit is selected for the corresponding application.

Besides a wide variety of travel wheel types from the standard range, special designs are also available to meet customer requirements. The housing, which is machined on all sides, can be connected to virtually any customer design. Offset and angular geared motors from the Demag modular system are available for the driven variant as individual or central drive units.

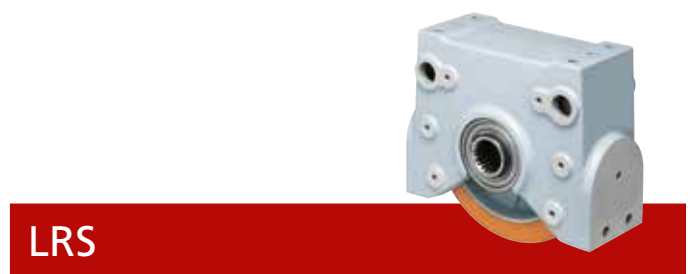
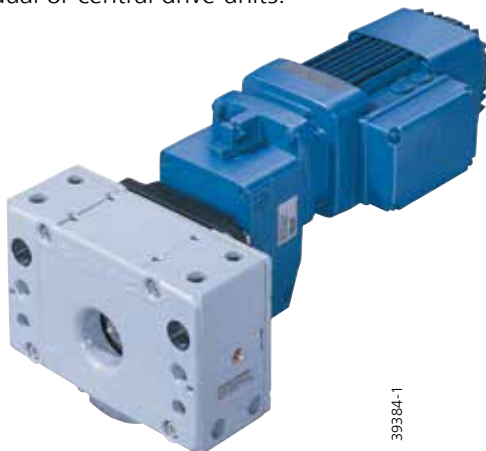

LRS

The LRS travel wheel system

A robust, universal travel wheel system for the lower load range up to 14,300 lbs (6.5 t). Simple project engineering makes it the ideal assembly for engineers that want to build their own solution for a wide variety of travel applications.

Two standard designs for each size – travel wheel with Hydropur tire and a spheroidal-graphite cast-iron travel wheel with two flanges – are available pre-assembled from stock and can be supplied in a minimum of time. Standard offset geared motors can be assigned by means of selection tables for driven designs.

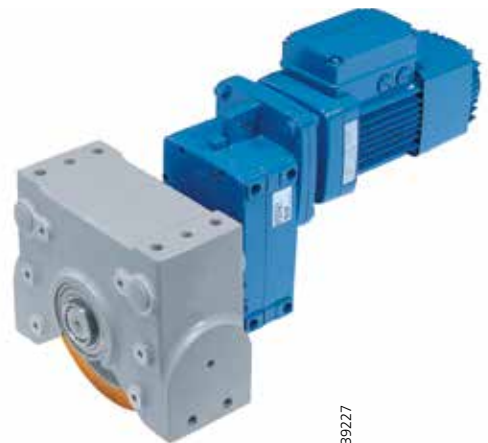



38698-15



37473-17



38224



RS



DWS

The Demag RS wheel block system

The system is suitable for special applications in which a stainless design or a housing made of sheet steel is required, as well as for high temperature applications (up to 482°F / 250°C). Various (RS 125 to RS 400) sizes can be supplied with load capacities from 7,700 to 39,600 lbs (3.5 to 18 t).

Various travel wheel designs and means of connection to customer structures also make this standard component suitable for universal applications. Demag offset geared motors can be used as drive units.

The DWS wheel set

This wheel set is the right choice for applications in the highest load range. Sizes can be supplied with travel wheel diameters of 400, 500 and 630 mm with load capacities from 61,700 to 132,200 lbs (28 to 60 t).

DWS wheel sets are suitable for integration into hollow-profile sections or for corner-bearing arrangements. They can be supplied as driven or non-driven units, with Demag offset or angular geared motors being used as the drive.

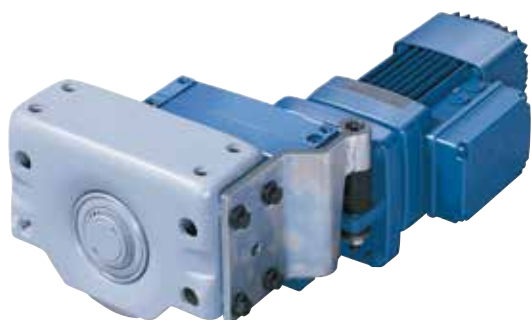

39383-1

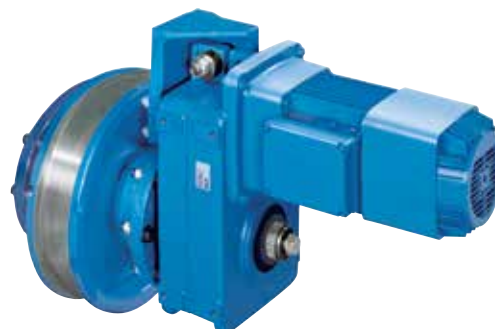

39398-2

Demag DRS wheel block system – versatility and high performance

The Demag DRS wheel block system offers outstanding benefits – from project engineering to commissioning of your installation. Wheel blocks are excellent solutions for a wide variety of applications. They also provide particularly high performance, i.e. a maximum load capacity with reference to the travel wheel diameter.

Protected travel wheels

The housing, enclosed on five sides, protects the travel wheels from any external mechanical influences. For DRS sizes 112 to 200, the housing is of high-quality, corrosion-resistant, die-cast aluminium with a powder coating up to 90 µm thick. From size DRS 250, high-tensile spheroidal-graphite cast-iron with a RAL 7001 finishing coat is used. Any housing openings that are not required can be closed with the plugs included in the delivery.



Many wheel variants

The system features wheels of various shapes and designs, made of spheroidal-graphite cast-iron or featuring Hydropur tires. The driven travel wheel design differs from non-driven wheels by a splined engaging profile in various diameters to DIN 5480.

Simple wheel replacement

The patented asymmetrical housing eliminates the need for time-consuming removal and realignment of our top-mounted DRS wheel blocks when travel wheels have to be replaced. The housing remains connected to the installation. This job can be completed using conventional tools. Wheel blocks can also be converted just as quickly and easily at a later date and fitted with travel wheels of a different design or material.

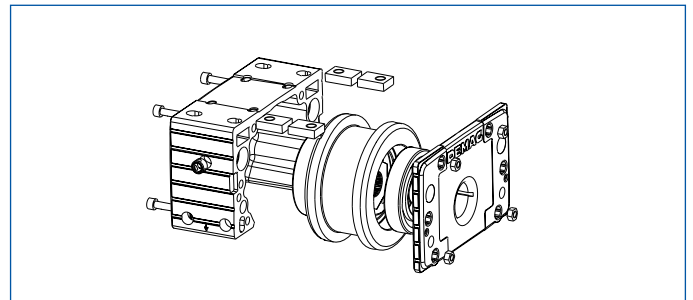



Easy to install and rigid design

The tight design and position tolerances of the housing and corresponding precise geometry in all planes ensure that Demag wheel blocks can be easily fitted to your installation, with starting and braking characteristics which are gentle on the runway. In addition, special stiffeners guarantee high rigidity.

Precise alignment

We have developed a laser alignment system to eliminate any problems in aligning wheel blocks. Together with prepared brackets on the housing of DRS 112 to DRS 500 wheel blocks, this system makes it possible to align wheel blocks mounted on multiple trolleys rapidly and exactly in line with each other.

Low-maintenance bearings

The travel wheels feature generously dimensioned grooved ball bearings, and tapered roller bearings from size DRS 250, which are lubricated for life. Arranged inside the housing, the bearings have optimum protection against mechanical influences.

High ground clearance

Of particularly compact design, DRS wheel blocks feature high ground clearance. This also applies to complete drive units with their gearbox concept designed to match the wheel load.

Patented solutions

The Demag DRS wheel block system features numerous new and, in part, patented design solutions such as the torque bracket, the travel wheel bearing arrangement, the travel wheel hub connection, the sliding nuts in the top connection (DRS 112 to DRS 250), and also the housing design.

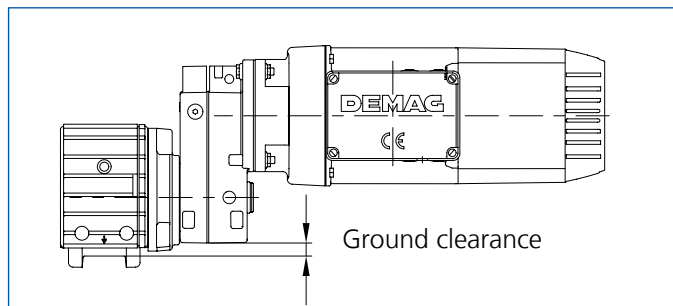
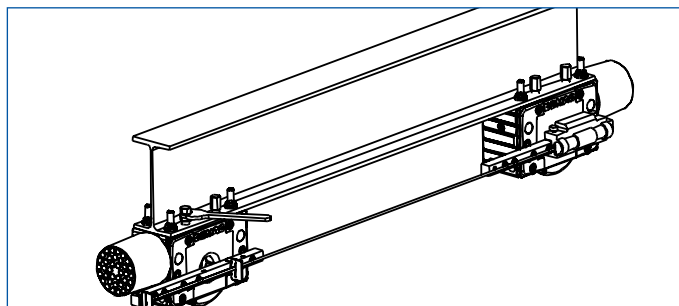

Demag DRS wheel block system – modular system for tailor-made solutions

The Demag DRS wheel block system with its wide variety of perfectly matched components will meet all your requirements. Demag DRS wheel blocks can be matched to many different types of travel rail and operating conditions with travel wheels from a wide range of standard designs or with specially developed travel wheel profiles – as cost-effective units ready for installation.



Travel wheel variants and materials

With effective vibration-damping characteristics, the spheroidal-graphite cast-iron (GGG 70) travel wheels guarantee high-speed operation which is particularly gentle on the rail. The self-lubricating effect of the wheel material reduces friction and provides high resistance to wear. These properties make spheroidal-graphite cast-iron travel wheels far superior to conventional steel travel wheels.

Also available are Polyamide travel wheels without flanges, which offer particularly smooth and quiet running properties and are gentle on the runway. Flangeless travel wheels fitted with Hydropur tires, which also provide for smooth operation at high acceleration rates, complete the range of materials used for our travel wheels.

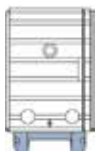

Travel wheels guided by flanges on both sides, with generous wear reserves for common rail systems or with a tread to your specifications.



Travel wheels for guided applications in vertical and horizontal planes of prismatic or trapezoidal design or with a concave tread.



Travel wheels without flanges, if required with guide rollers for rigidly guided systems.

Spheroidal-graphite cast-iron wheels with a convex tread or of hardened design can also be supplied.

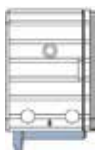

Travel wheels guided by a flange on one side for units running at floor level, also with a central flange for special requirements.

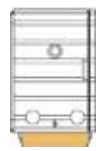

Flangeless travel wheels with a Hydropur tire for high acceleration and quiet running characteristics.

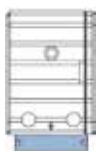

Large diameter travel wheels without a flange for increased ground clearance.



Polyamide travel wheels without a flange for quiet running and gentle on the runway.

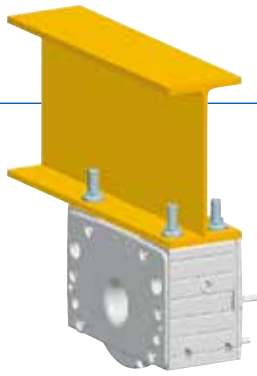

Top connection

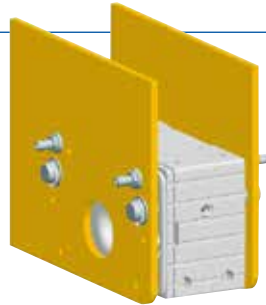

Pin connection

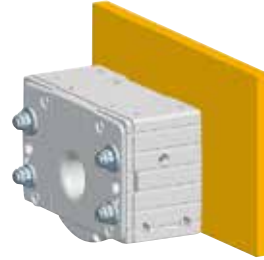

Side connection

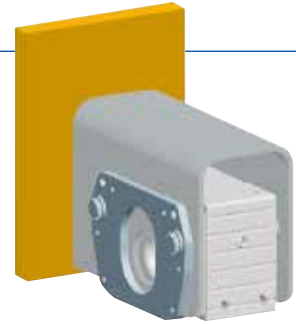

End connection

Connection variants

Prepared mounting surfaces facilitate virtually any connection arrangement – ranging from top and end connection arrangements with bolted and welded connection elements, to side and pin connection arrangements for installation in hollow sections and cross beams. Top, end and pin connection arrangements make it possible to move and align the wheel blocks laterally even after they have been fitted.

Guide arrangement variants

Tailored solutions are also available for guiding wheel blocks. Flange-guided travel wheels and wheels with prism-shaped or concave treads for round cross section rails provide for exact vertical and horizontal guide arrangements. If strong horizontal forces have to be reliably absorbed, infinitely adjustable guide rollers with a positive connection should be used.

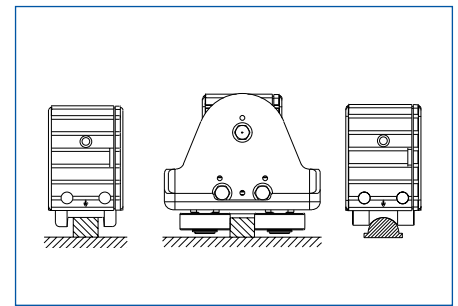
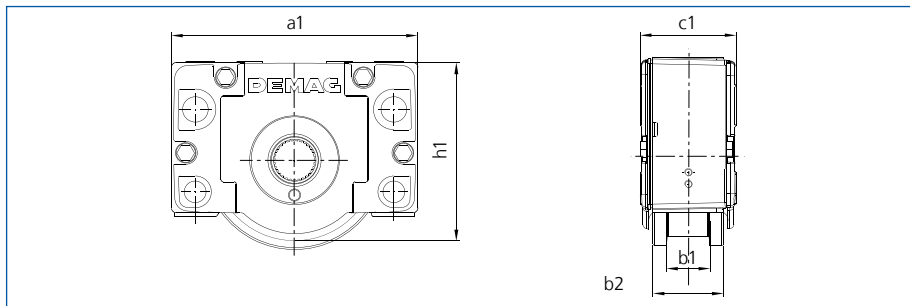

Dimensions (DRS with spheroidal-graphite cast-iron wheel with two flanges)

Size	Max. load capacity [lb] / [kg]	Travel wheel diameter [in] / [mm]	Weight [lb] / [kg]	[in] / [mm]				
				a1	b1	b2	c1	h1
DRS 112	6,000 / 2,750	4.4 / 112	16 / 7.3	7.48/190	1.85/47	3.15/80	3.78/96	5.16/131
DRS 125	11,000 / 5,000	4.9 / 125	22 / 9.9	8.66/220	2.36/60	3.15/80	3.85/98	5.8/147,5
DRS 160	15,400 / 7,000	6.3 / 160	40 / 18.3	10.8/275	2.55/65	3.5/89	4.33/110	7.36/187
DRS 200	22,000 / 10,000	7.9 / 200	80 / 35.7	13.3/340	2.55/65	3.97/101	5.11/130	9.37/238
DRS 250	35,000 / 16,000	9.8 / 250	140 / 62	15.1/385	2.95/75	4.33/110	5.91/150	11.1/281
DRS 315	48,400 / 22,000	12.4 / 315	260 / 117	18.5/470	3.54/90	5.11/130	7.1/180	13,75/349,5
DRS 400	66,000 / 30,000	15.7 / 400	445 / 201	22.8/580	4.33/110	6.1/155	8.27/210	17.3/440
DRS 500	88,000 / 40,000	19.7 / 500	775 / 352	27.5/700	4.33/110	6.7/170	9.44/240	22.3/566

Options and accessories

Horizontal guide roller arrangements, rail-sweeper systems and buffers are available in various sizes and designs.

The right drive – precisely matched to the Demag wheel range

Demag drive system components consisting of motors and gearboxes as well as inverters for particularly smooth and precise acceleration, braking and positioning are exactly matched to the Demag wheel range. The perfect combination of all components turns installations into efficient systems.

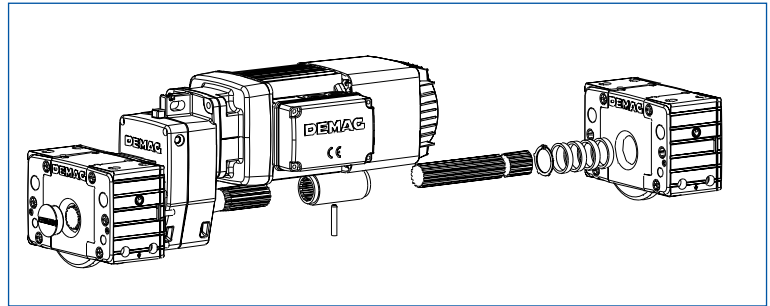

Central drive unit with offset geared motor

The direct drive input with a cylindrical-rotor motor and an additional flywheel variant is characterized by a shallow torque curve. The additional flywheel, arranged close to the offset or angular gearbox, also provides an optimum center of gravity for the drive.

The drives can also be designed with one motor to drive two wheel blocks. These central drive arrangements guarantee absolute synchronous operation of pairs of wheel blocks.

The coupling connection variant has the advantage that it can also be driven by our high performance conical-rotor brake motors with their high starting frequency and braking capacity.

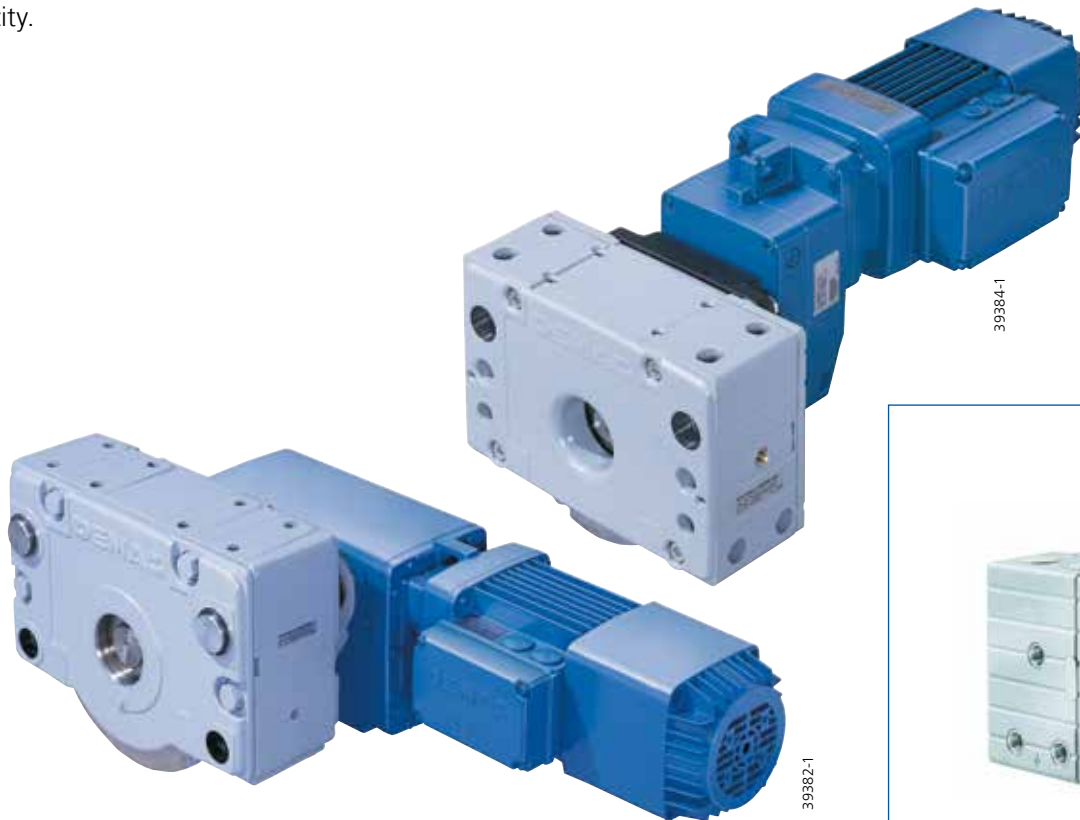



In combination with the relevant torque bracket, the integrated torque ring cast into the housing cover of our offset gearboxes makes it possible to fix the drive in various positions relative to the DRS wheel block – in 15° steps to provide an optimum fit of the drive into the connecting structure.

Furthermore, the patented torque bracket enables the torque to be transmitted from the geared motor to the wheel block without any radial force. This reduces the load on the drive shaft and extends its service life.

In addition to special Demag travel motors for line-fed operation – also available as pole-changing units for two speeds – we offer standard drive motors with frequency inverters for electronically controlled operation, e.g. for exact positioning at low speeds. There are two frequency inverter ranges: Dedrive Compact for motor outputs up to 40.2 HP (30 kW) and Dedrive Pro for motor outputs up to 750.9 HP (560 kW).

Demag FG microspeed drives provide outstanding characteristics if a wide ratio is required between the “positioning speed” and “fast speed”. They can be used to achieve transmission ratios of up to 500:1 with line-fed drives without the need for an inverter.

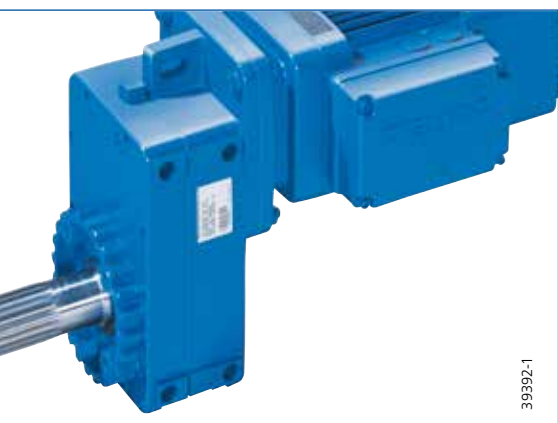

Drive Designer online – practical project engineering support

You can obtain online support for your project engineering and design work at www.demag-drivenodesigner.com. Drive Designer facilitates rapid access to technical data and drawings of Demag wheel blocks and geared motors via the Internet. Use it as a configurator, for project engineering support and for enquiries.



www.demag-drivenodesigner.com



Selection of the required wheel blocks is usually based on the planned load capacity. The speed at which a particular mass needs to be transported is also decisive.

The corresponding components are specified by entering the known parameters, such as the temperature range, cycle times, rail type and materials. The result is a complete, distinct type code. Any required options can also be selected. A data sheet shows all relevant technical data.

You can generate the corresponding dimension diagrams and product geometry details in the usual CAD formats for the selected combinations. Circuit diagrams show the electrical connections for the motor.

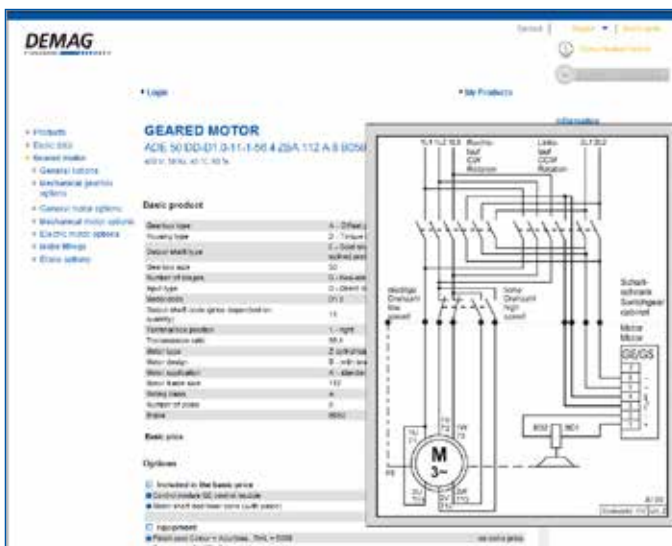

In addition to the configuration of complete 4-wheel carriages, travel units consisting of one, two, four or more wheel blocks can be individually designed and configured. Both offset gearboxes and angular gearboxes can be selected.

When the configuration has been specified, the wheel blocks can be ordered direct in Demag Shop at www.demag-shop.com.



Selection of various CAD formats

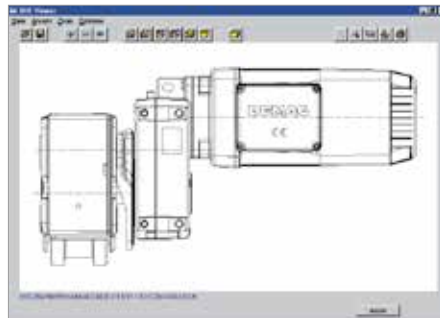

Individual 2D CAD files

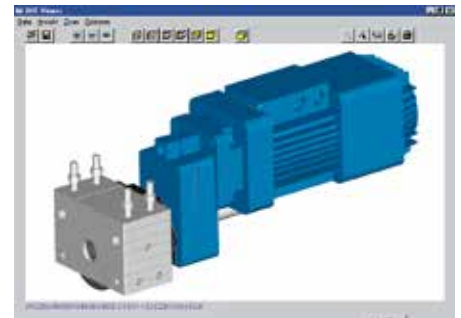

3D product geometries

Calculate the right drive with CalDrive

The required output, loads and speeds need to be entered into Drive Designer to select travel units. Alternatively, the travel unit can be selected on the basis of the complete mounting code.

CalDrive calculation software is used to determine the required drive data from the specified physical characteristics.

The basic characteristics and data of Demag geared motors and wheel blocks are included in CalDrive. Drives for travel and hoist applications, as well as for roller, chain or belt conveyors can be specified with ease. The program suggests solutions for the combination of our offset, angular and helical gearboxes with cylindrical or conical-rotor motors. You can also determine solutions for line-fed or frequency inverter systems, of course. Besides the technical data, you are also shown acceleration and deceleration values in the result.

You can request the current version of the multi-lingual CalDrive calculation program on CD-ROM free of charge at www.drives.demagcranes.de.



Demag LRS travel wheel system – universal solution for loads weighing up to 14,300 lbs (6.5 t)

The Demag LRS travel wheel system is a robust, universal travel wheel system suitable for a wide range of applications. It is the solution for travel applications with wheel loads weighing up to 6.5 t (at 100 m/min; 325 ft/min) and travel speeds up to 780 ft/min (240 m/min). Simple project engineering makes it the ideal assembly for engineers that want to build their own solution for a wide variety of travel applications.

Robust and maintenance-free

The LRS system requires virtually no maintenance and is suitable for operation at ambient temperatures from -14°F to 104°F (-10°C to +40°C). The five precisely machined connecting surfaces of the extremely rugged spheroidal-graphite cast housing block offer a wide range of connection variants. It is fitted with top-connection bolts as standard. The LRS travel wheel system is available in two designs:

- **LRS...A** with a spheroidal-graphite cast-iron travel wheel and two flanges with high load capacity and good rolling and damping characteristics
- **LRS...F** as a travel wheel with a Hydropur tire for very good traction and quiet running characteristics

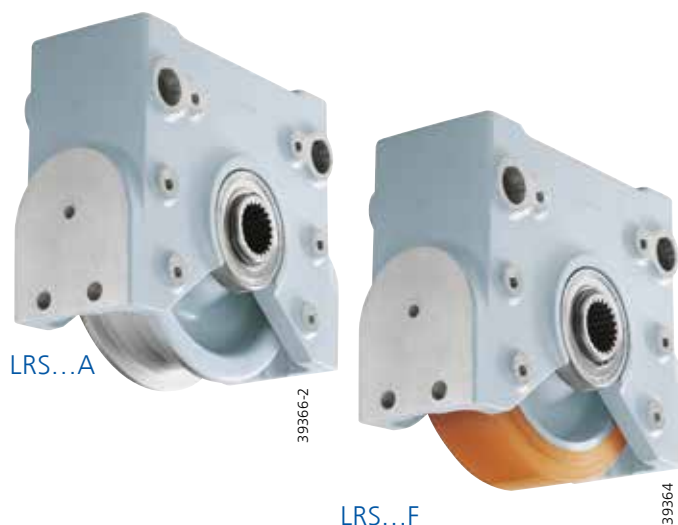

Also available as optional accessories: a pin connection set, a buffer set, horizontal guide roller arrangement and central drive unit set for track gauges of 59 in. (1,500 mm) and 114 in. (2,900 mm).

Drive

Demag offset and angular geared motors are ideally suited as travel drives for the Demag LRS system. The gearbox is connected to the LRS system with a hollow shaft featuring involute splines (to DIN 5480) by means of a shaft system and a matching torque bracket.

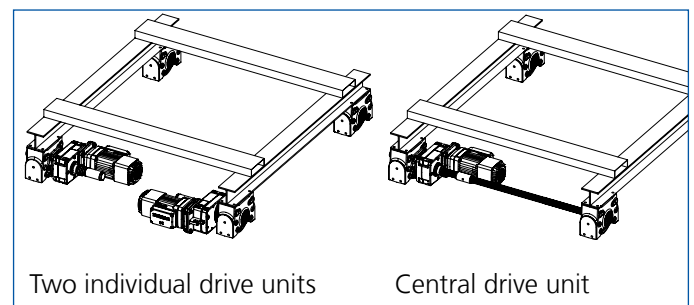

Various gearbox sizes are available with corresponding travel motors depending on the load to be moved and the required speed. Pole-changing geared motors can be selected from tables for line-fed operation (400 V, 50 Hz).

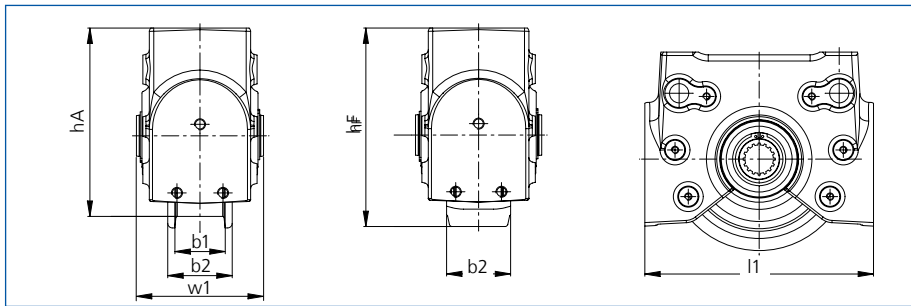

LRS...A

LRS...F

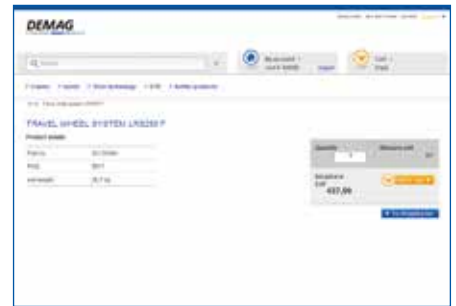

www.demag-shop.com

From CAD model to convenient online order

To facilitate integration of the selected LRS components into your design, we offer 2D and 3D files online at www.lrs.demagcranes.com. Choose your CAD format after selecting the required components.

The following formats are available:

- 2D CAD files: DXF¹⁾, DWG
- 3D CAD files: IGES, STEP, Pro/Engineer
- Dimension sheets: PDF

¹⁾ The DXF Viewer is available free of charge to view the files.

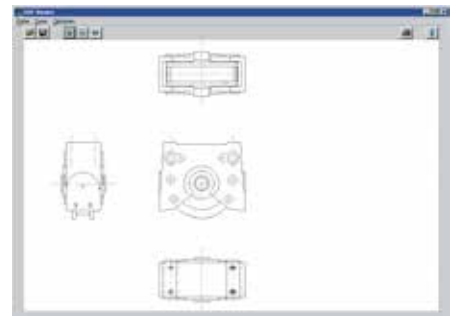

2D CAD files

In the Demag Shop system, you can either reserve or order the required component parts direct, specifying the shipping method as well as the required delivery date. When you have ordered components, we will immediately advise you of our order number and the calculated delivery date.



3D CAD files

Dimensions

Size	Travel wheel	Max. load capacity [lb] / [kg]	Travel wheel diameter [in] / [mm]	Weight [lb] / [kg]	[in] / [mm]					
					l1	w1	hA	hF	b1	b2
LRS 200	A	5,500 / 2,500	6.9 / 175	34 / 15.3	9.84 / 250	5.43 / 138	8.05 / 204.5	9.53 / 242	2.05 / 52	2.75 / 70
	F	2,640 / 1,200	7.9 / 200	33 / 15.1					–	2.75 / 70
LRS 250	A	7,700 / 3,500	8.6 / 220	61 / 27.6	12.0 / 306	6.14 / 156	10.0 / 255	10.6 / 270	2.17 / 55	3.15 / 80
	F	3,740 / 1,700	9.8 / 250	59 / 26.7					–	3.15 / 80
LRS 350	A	14,300 / 6,500	12.4 / 315	140 / 63.0	17.7 / 450	7.9 / 200	14.2 / 359.5	14.4 / 367	2.56 / 65	3.74 / 95
	F	6,000 / 3,000	13.8 / 350	145 / 65.0					–	4.33 / 110

Demag RS wheel block system – the solution for special requirements

The RS wheel block system consists of a housing welded together from two sheet steel halves with an integrated travel wheel. It can be attached to customer structures with ease using the prepared connecting surfaces. The varied connection possibilities also make it simple to add it to existing installations at a later date.



Main RS features

- Load-bearing block enclosed on 5 sides with connecting surfaces featuring multiple bore holes
- Reamed lateral bore holes for the pin connection
- Integrated connections for torque brackets, guide roller arrangements and buffers
- Steel housing primed and finished with a top coat in RAL 7001
- Long service life of the steel and mechanical elements
- Rapid installation and removal for all connection variants
- Wide variety of standard travel wheel designs

For particularly tough applications

The special designs for high temperature applications up to 302°F (150°C) or with furnace carriage bearings up to 482°F (250°C) are a special feature of the RS wheel block system. The RS 125 size is available in stainless steel. It is particularly suitable for applications in the chemical industry, the foodstuffs sector and in aggressive environments.

Drive

The gearbox has a hollow shaft featuring involute splines on the output side. The positive connection to the travel wheel shaft guarantees reliable torque transmission. This is particularly important for reversing and intermittent operation. The modular Demag system includes the D1 torque bracket (fitted direct to the wheel block) or D2 torque bracket (fitted to the customer's support superstructure) to accommodate the torque transmitted by the drive.

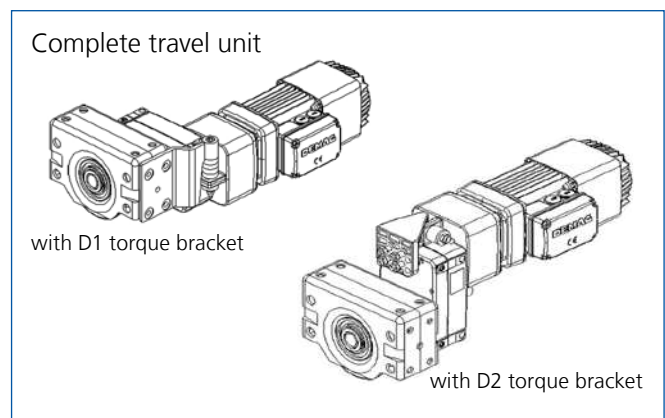



Connection variants

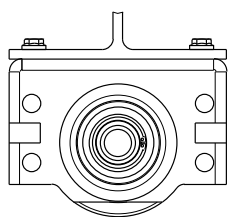

Top connection

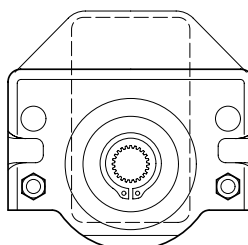
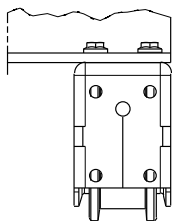

Side connection

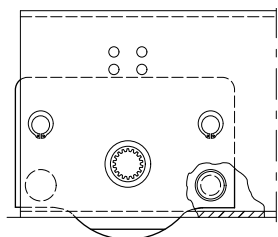
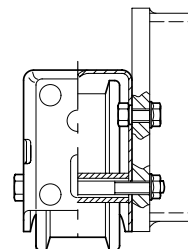

Pin connection

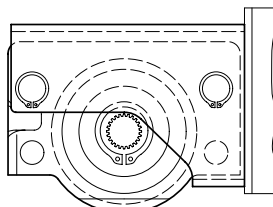
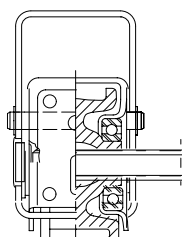

End connection

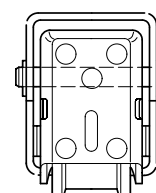

CAD drawings are available in various formats at www.demag-drivenedesigner.com to support your design process.

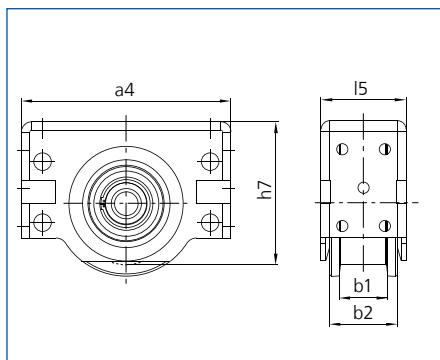

Dimensions

(RS with spheroidal-graphite cast-iron wheel with two flanges)

Size	Max. load capacity [lb] / [kg]	Travel wheel diameter [in] / [mm]	Weight [lb] / [kg]	[in] / [mm]				
				a4	l5	h7	b1	b2
RS 125	7,700 / 3,500	4.9 / 125	17.5 / 8.0	8.66 / 220	3.85 / 98	5.83 / 148	2.36 / 60	2.68 / 68
RS 160	11,000 / 5,000	6.3 / 160	33 / 15	10.8 / 275	4.33 / 110	7.36 / 187	2.36 / 60	2.95 / 75
RS 250	19,800 / 9,000	9.8 / 250	88 / 40	15.1 / 385	5.9 / 150	11.1 / 281	2.55 / 65	3.94 / 100
RS 315	26,400 / 12,000	12.4 / 315	145 / 65	18.5 / 470	7.1 / 180	13.8 / 350	2.55 / 65	4.33 / 110
RS 400	39,600 / 18,000	15.7 / 400	340 / 153	22.8 / 580	8.3 / 210	17.3 / 440	3.15 / 80	5.5 / 140

Demag DWS wheel set – the perfect solution for heavy loads

Demag travel units are also used for rail-guided travel applications for heavy loads. DWS wheel sets are offered as driven and non-driven types to provide complete travel units. Demag offset or angular geared motors are used as drive units.



The use of these proven series-manufactured components offers a high level of functional reliability and guarantees interchangeability when the wheel is replaced.

Owing to their versatility, DWS wheel sets are not only used in the crane and materials handling sector, but also for related mechanical engineering solutions.



39399-2

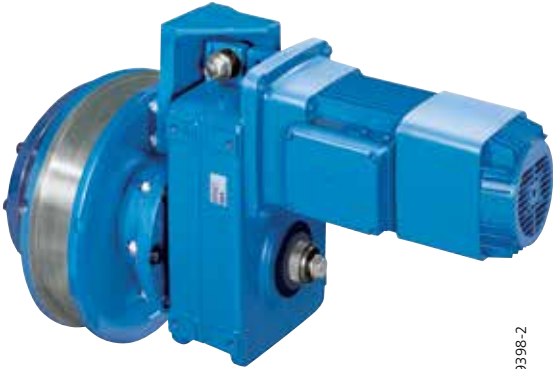

39398-2



40072-1

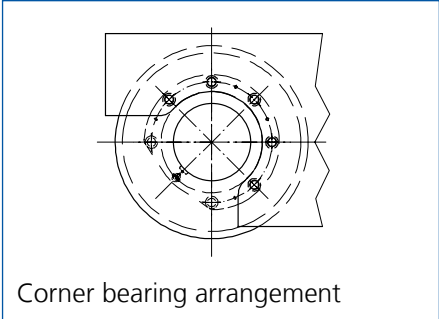
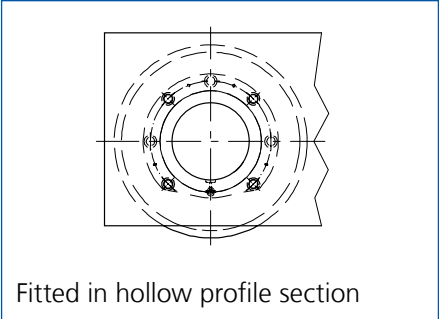
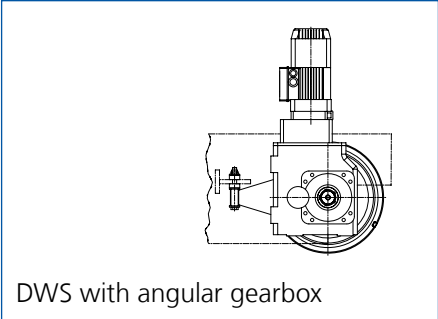



The wheel sets can be installed in hollow profile sections and box girder sections and as corner bearing units. Corner bearing arrangements offer the advantage of installing a pre-assembled wheel set in a travel unit without the need for extensive alignment. The unit can be rapidly replaced without the need for any alignment work, which ensures a high level of availability.

Drive

Demag AUK/ADK offset gearboxes or WUK angular gearboxes with Z motors with direct drive input or with a coupling connection with KB motors are used as the drives. The D2 or Arm2 torque bracket is also fitted to the supporting structure to form a complete solution with the motor and gearbox.

Design features

- Simple track gauge adjustment thanks to interchangeable distance washers between the anti-friction bearings and retaining rings
- Rapid installation and removal of the travel wheel from the travel unit using conventional tools
- Long service life thanks to standard re-lubrication facility
- Driven design matched to Demag offset or angular geared motors
- Guide flange wear indicator
- Flange bearings provided with recesses to attach extractors.

CAD drawings are available in various formats at www.demag-drivenesigner.com to support your design process.

Dimensions

Size	Max. load capacity [lb]/[kg]	Travel wheel dia. d1 [in]/[mm]	Weight [lb]/[kg]	[in]/[mm]				
				I5	I6	d2	b1*	b2
DWS 400	61,600 / 28,000	15.7 / 400	230 / 105	11.0 / 280	14.3 / 362	17.2 / 437	3.2 / 80 3.5 / 90	4.9 / 125 5.5 / 140
DWS 500	88,000 / 40,000	19.7 / 500	315 / 142	12.6 / 320	15.8 / 402	21.1 / 537	3.5 / 90 4.3 / 110	5.5 / 140 6.7 / 170
DWS 630	132,000 / 60,000	24.8 / 630	685 / 310	13.8 / 350	17.9 / 456	26.8 / 680	2.9 / 75 4.3 / 110	5.5 / 140 6.7 / 170

* Special treads on request

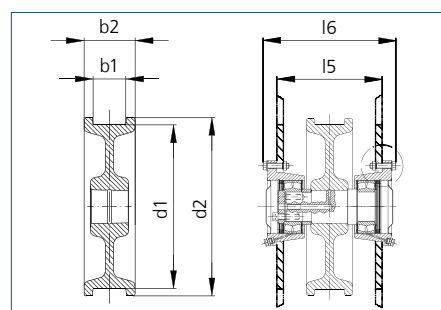

Complete industrial drive solutions – from wheels to inverters

Demag geared motors

- Helical geared motors from 66 to 1,328 lb-ft (90 to 1,800 Nm)
- Angular geared motors from 88 to 8,850 lb-ft (120 to 12,000 Nm)
- Offset geared motors for 95 to 8,480 lb-ft (130 to 11,500 Nm) with cylindrical-rotor motors from 0.18 to 45 kW (.24 to 60 hp)

Demag conical-rotor brake motors

For increased requirements such as extremely high switching frequencies and braking operation for outputs from 0.37 to 42 kW (.5 to 56 hp)

Demag microspeed drives

With conical-rotor motors; for high speed stages and positioning with high stopping accuracy; speed ratios up to 500:1

Demag Dedrive Compact STO and Dedrive Pro frequency inverters

For AC drives with motor shaft outputs up to 560 kW (750 hp); control of cylindrical and conical-rotor motors as single or groups of drives; current loads from 2.4 to 210 A or 4.2 to 544 A

Demag travel unit components

Modular systems for elements in materials handling installations and mechanical engineering applications without the need for any additional design work and production:

- DRS wheel block system; many wheel variant and connection options, high performance; load capacities from 6,000 to 88,100 lbs (2.75 t to 40 t)
- RS wheel block system; with sheet-steel housing for special applications, also in high-temperature range up to 482°F (250°C)
- LRS travel wheel system; the simple system for the lower load range up to 14,300 lbs (6.5 t)
- DWS wheel set; for integration into hollow-profile sections or for corner-bearing arrangements; load capacity up to 132,200 lbs (60 t)

Demag DCL-Pro Compact Line

Power feed system; designed for currents up to 200 A (100% CDF); fitted with up to 7 conductors, as required; for supplying mobile consumers with power.

Terex MHPS Corp.

29201 Aurora Road
Cleveland, Ohio 44139
Phone: (440) 248-2400
Fax: (440) 248-3874
www.demag-us.com