

Clutch Products



TB Wood's

TB Wood's is an industry leading designer and manufacturer of mechanical power transmission equipment for industrial control. Our mechanical product lines include: clutch and brake, synchronous and belted variable speed drives; grid, disc, jaw, gear coupling and elastomeric coupling products; sheaves and bushings. Registered trademarks include Sure-Flex®, Dura-Flex®, G-Flex®, and QT Bushings®.

TB Wood's was founded in 1857 and began as a foundry producing wood burning stoves. Our company's tradition of product innovation started early. Wood's entered the power transmission industry at the turn of the century with the introduction of flat belted drives and line shafting.

In April 2007, TB Wood's was purchased by Altra Holdings, Inc. This acquisition placed TB Wood's as part of a larger company with complementary products to help grow the business.



Altra Industrial Motion

Altra is a leading multinational designer, producer and marketer of a wide range of mechanical power transmission products. We sell our products in over 70 countries throughout the world. Our products are frequently used in critical applications, such as fail-safe brakes for elevators, wheelchairs and forklifts, and in high-volume manufacturing processes, where the reliability and accuracy of our products are critical in both avoiding costly down time and enhancing the overall efficiency of manufacturing operations.

Our products are marketed under a variety of well recognized and established manufacturing brand names. These leading brands are Ameridrives, Boston Gear, Warner Electric, Formsprag Clutch, TB Wood's Incorporated, Industrial Clutch, Kilian Manufacturing, Marland Clutch, Nuttall Gear, Stieber Clutch, Twiflex Ltd, Huco Dynatork, Bibby Turboflex, Matrix International, Inertia Dynamics, Delroyd Worm Gear, Warner Linear, Wichita Clutch and Lamiflex Couplings.

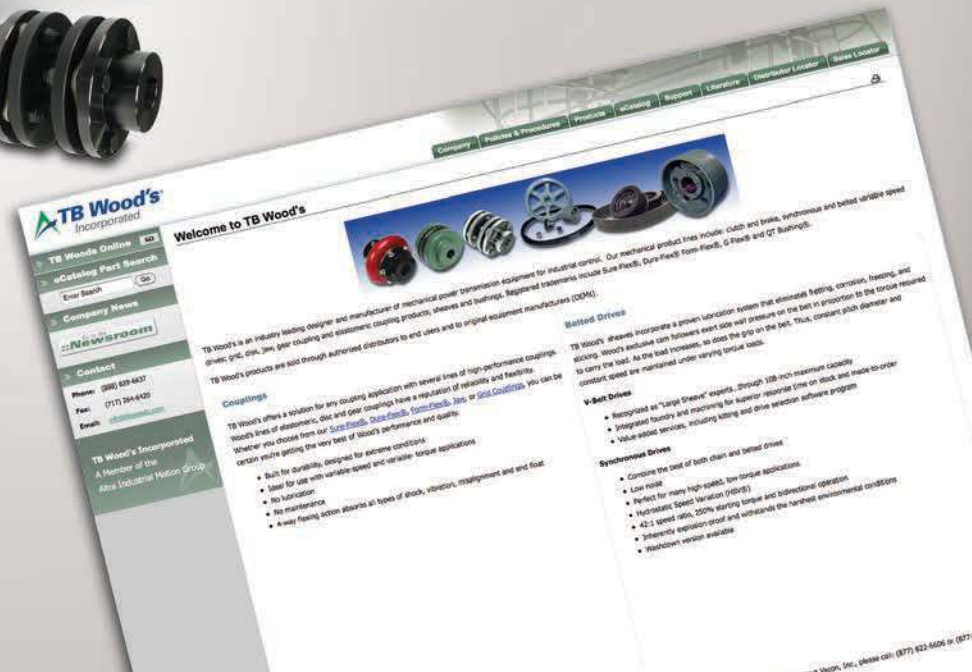

Section G1

NLS[®] – Centrifugal Clutch

(No Load Start)

- cushion for high inertia starting loads
- dampens shock starts
- systems overload protection



Section G2

Roto-Cam[®] – Mechanical Clutch

- simple design
- smooth cam actuated engagements
- sealed for dirty or dusty applications
- no lubrication

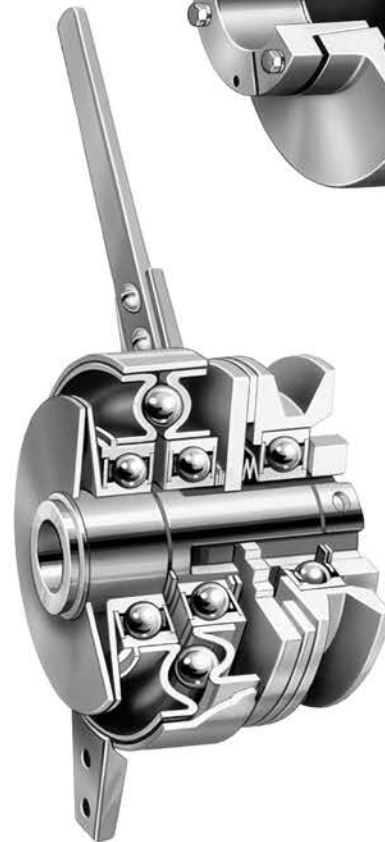

Section G3

Disc-O-Torque[®] – Hydraulic Clutch

- minimum size / maximum torque
- lubricated and sealed bearing types
- air or oil activation
- long life

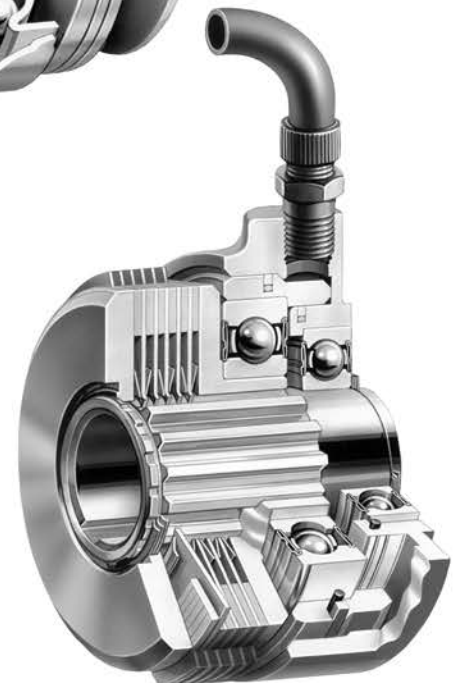

NLS® Centrifugal Clutch

The NLS centrifugal clutch is a rugged time-proven unit which provides equipment protection and system overload protection. This is done by allowing the motor or other driving source to accelerate to operating speed without load and to slip automatically when overloaded. This clutch is available in a free (type A) and delayed engagement (type AD) model, also in various sizes to handle different horsepower capacities.

TYPE A

Free Engagement

The shoes are a free floating part of the driving unit to which the power is applied. As the driver picks up speed, the shoes are forced outward by centrifugal force to make contact with the inside surface of the driven half. The shoes will make smooth contact and slip until the load reaches full speed. Both members then rotate as a unit with no slippage or power loss. Larger units have both inner and outer shoes.

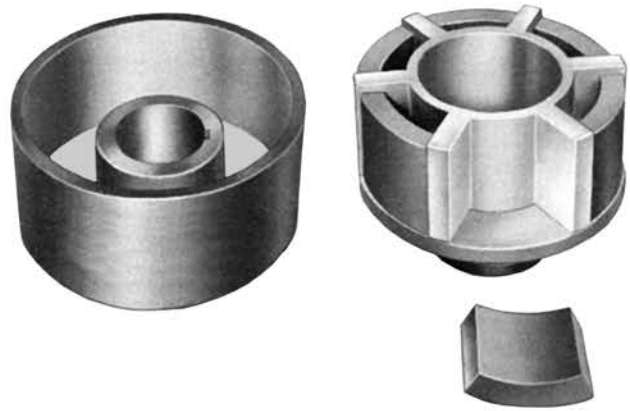

**TYPE A
WITH ONE ROW OF SHOES**

TYPE AD

Delayed Engagement

Operating under the same principle as the type A unit, the type AD uses springs to hold the shoes out of engagement until the driver reaches a predetermined rpm. At this point centrifugal force, acting on the shoes, overcomes the spring force, allowing smooth engagement of the power source with the load. Because the shoes are out of engagement until the driver is above the predetermined speed, this unit is ideal for dual or stand-by drives as well as idling or warming-up engines.

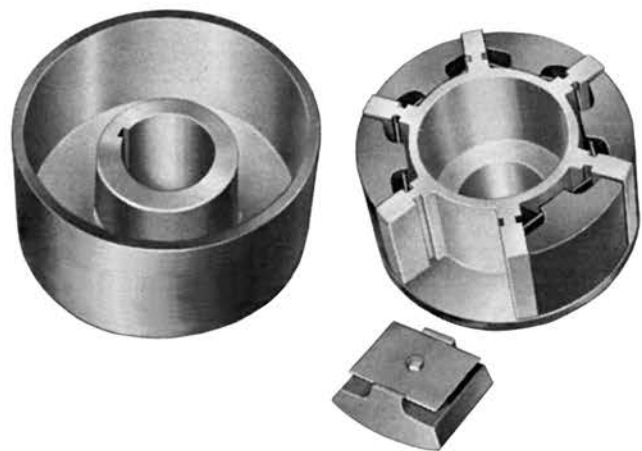

**TYPE AD
FOR DELAYED ENGAGEMENT**

NLS® Selection Procedure (continued)

Step # 3: Calculate the Design HP (HP x service factor). Using the Design HP and the driving RPM select the type and size clutch from the following charts.

TYPE A

Free Engagement Horsepower Tables

In Wood's NLS free engagement clutch the shoes are a free-moving part of the driving half of the two-piece unit to which the power is applied. As the driving half picks up speed the shoes are forced outward by centrifugal force into contact with the inside surface of the driven half which is attached to the load or driven machine. As the shoes make smooth contact, they slip momentarily, or until friction causes the driven half to rotate. When the driven equipment reaches full speed, complete engagement of the shoes with the driven half has taken place, and both members rotate as a unit with **no slip-page, or power loss.**

Description	Bushing	Product Number	Minimum Dynamic HP							Shoe Replacement			
			Minimum Driving RPM							Outer		Inner	
			400	500	600	720	870	1160	1750	Product No.	Qty.	Product No.	Qty.
4A-1	SH	N004-1	0.02	0.04	0.07	0.11	0.20	0.50	1.60	N004-408	2	NONE	
4A-2	SH	N004-2	0.04	0.07	0.13	0.23	0.40	0.90	3.30	N004-408	4	NONE	
4A-3	SH	N004-3	0.05	0.09	0.15	0.27	0.50	1.10	3.90	N004-412	4	NONE	
6A-1	SDS	N006-1	0.09	0.20	0.30	0.50	1.00	2.40	8.00	N006-613	2	NONE	
6A-2	SDS	N006-2	0.15	0.30	0.50	0.90	1.60	3.80	13.00	N006-613	3	NONE	
6A-3	SDS	N006-3	0.20	0.40	0.70	1.20	2.10	5.00	17.00	N006-613	4	NONE	
6A-4	SDS	N006-4	0.29	0.60	1.00	1.80	3.20	7.50	26.00	N006-613	6	NONE	
7A-1	SK	N007-1	0.38	0.75	1.30	2.20	3.90	9.40	32.00	N007-726	3	NONE	
7A-2	SK	N007-2	0.51	1.00	1.70	3.00	5.20	12.00	43.00	N007-726	4	NONE	
7A-3	SK	N007-3	0.77	1.50	2.60	4.50	7.90	19.00	64.00	N007-726	6	NONE	
8A-1	SF	N008-1	0.90	1.80	3.20	5.60	9.80	23.00	80.00	N008-834	4	NONE	
8A-2	SF	N008-2	1.00	2.00	3.60	6.00	11.00	26.00	88.00	N008-842	4	NONE	
8A-3	SF	N008-3	1.30	2.70	4.90	8.20	14.00	35.00	120.00	N008-834	6	NONE	
8A-4	SF	N008-4	1.50	3.00	5.40	9.10	16.00	38.00	132.00	N008-842	6	NONE	
10A-1	E	N010-1	1.50	3.00	5.50	9.00	16.00	38.00	132.00	N010-1033	4	N010-1026-I	4
10A-2	E	N010-2	1.50	3.50	6.00	10.00	18.00	43.00	149.00	N010-1042	4	N010-1026-I	4
10A-3	E	N010-3	2.00	4.50	7.50	13.00	24.00	56.00	192.00	N010-1033	6	N010-1026-I	6
10A-4	E	N010-4	2.50	5.00	9.00	15.00	28.00	65.00	224.00	N010-1042	6	N010-1026-I	6
12A-1	F	N012-1	3.00	6.50	12.00	19.00	35.00	82.00	285.00	N012-1275	3	N012-1256-I	3
12A-2	F	N012-2	4.00	8.50	16.00	26.00	47.00	110.00	380.00	N012-1275	4	N012-1256-I	3
12A-3	F	N012-3	6.00	12.00	21.00	36.00	65.00	154.00	533.00	N012-1260	6	N012-1256-I	6
12A-4	F	N012-4	6.50	13.00	23.00	39.00	70.00	165.00	570.00	N012-1275	6	N012-1256-I	6
14A-1	F	N014-1	8.50	17.00	31.00	51.00	92.00	217.00	749.00	N014-1453	6	N014-1468-I	3
14A-2	F	N014-2	10.00	20.00	36.00	60.00	108.00	255.00	879.00	N014-1470	6	N014-1468-I	4
14A-3	F	N014-3	13.00	27.00	48.00	81.00	144.00	340.00	1170.00	N014-1470	8	N014-1468-I	6
16A-1	J	N016-1	13.00	26.00	47.00	79.00	141.00	333.00	1150.00	N016-16110	4	N016-16100-I	3
16A-2	J	N016-2	14.00	28.00	50.00	84.00	150.00	354.00	1220.00	N016-1685	6	N016-16100-I	4
16A-3	J	N016-3	20.00	39.00	70.00	118.00	212.00	499.00	1720.00	N016-16110	6	N016-16100-I	4
16A-4	J	N016-4	26.00	53.00	93.00	158.00	282.00	666.00	2290.00	N016-16110	8	N016-16100-I	6
19A-1	BTS	N019-1	43.00	87.00	154.00	260.00	461.00	1090.00	...	N019-19150	6	N019-19100-I	6
19A-2	BTS	N019-2	57.00	115.00	204.00	346.00	614.00	1450.00	...	N019-19150	8	N019-19100-I	8
24A-1	BTS	N024-1	77.00	156.00	276.00	468.00	828.00	1967.00	...	N024-24140	8	N024-24180-I	4
24A-2	BTS	N024-2	114.00	221.00	391.00	663.00	1170.00	2785.00	...	N024-24200	8	N024-24180-I	6
24A-3	BTS	N024-3	164.00	332.00	587.00	995.00	1760.00	4180.00	...	N024-24200	12	N024-24180-I	8
24A-4	BTS	N024-4	219.00	443.00	783.00	1327.00	2345.00	5570.00	...	N024-24200	16	N024-24220-I	8
25A-1	BTS	N025-1	246.00	498.00	881.00	1490.00	2640.00	6270.00	...	N024-24200	18	N024-24180-I	8
25A-2	BTS	N025-2	287.00	581.00	1030.00	1740.00	3080.00	7310.00	...	N024-24200	21	N024-24220-I	8
25A-3	BTS	N025-3	342.00	669.00	1160.00	2000.00	3530.00	8360.00	...	N024-24200	24	N024-24180-I	8

Horsepower tables are based on ideal test conditions. As with all friction clutches, the actual horsepower will vary with application conditions.

When using a model with inner shoes:

A) Horsepower ratings prior to shoe lock-up (dynamic horsepower ratings) do not include inner shoe.

B) Horsepower rating after complete shoe lock-up with inner shoe (static horsepower ratings) are approximately double the dynamic rating.

For high speed applications and models above 10", consult TB Wood's application engineering.

TYPE AD

Delayed Engagement Horsepower Tables

In Wood's NLS delayed engagement clutch, shoe engagement is controlled by springs. The springs are fastened to the clutch shoes and inserted in slots in the driving half. Spring action holds the shoes out of engagement with the driven half until the driving half reaches a pre-determined RPM. Above this RPM, centrifugal force acting on the shoes overcomes the spring force allowing smooth engagement of the power source with the driven equipment. Since the shoes do not contact the driven half unless the driving half is started and accelerated, the delayed engagement type AD is ideal for dual or standby drives. The cushioned contact also means no sudden load imposed on motor, electrical, clutch or driven equipment.

Description	Bushing	Product Number	Minimum Dynamic HP				Max Idle RPM	Shoe Replacement	
			Minimum Driving / Maximum Idle RPM					Outer	
			870/300*	1160/700*	1750/1000*	2500/1500*		Product No.	Qty.
4AD-1	SH	N104-1	0.18	0.31	1.10	3.20	300-1500	N104-9001	2
4AD-2	SH	N104-2	0.37	0.63	2.30	6.40	300-1500	N104-9001	4
6AD-1	SDS	N106-1	0.80	1.40	5.00	14.60	300-1500	N106-9001	2
6AD-2	SDS	N106-2	1.20	2.10	8.00	21.90	300-1500	N106-9001	3
6AD-3	SDS	N106-3	1.70	2.80	10.50	29.20	300-1500	N106-9001	4
6AD-4	SDS	N106-4	2.50	4.30	15.50	43.80	300-1500	N106-9001	6
7AD-1	SK	N107-1	3.00	5.00	18.50	50.00	300-1500	N107-9001	3
7AD-2	SK	N107-2	4.00	6.80	24.50	67.00	300-1500	N107-9001	4
7AD-3	SK	N107-3	6.00	10.90	37.00	100.00	300-1500	N107-9001	6
8AD-1	SF	N108-1	7.50	13.00	47.00	136.00	300-1500	N108-9001	4
8AD-2	SF	N108-2	11.50	19.50	71.00	204.00	300-1500	N108-9001	6
10AD-1	SF	N110-1	17.00	30.00	109.00	—	300-1000	N110-9001	4
10AD-2	SF	N110-2	26.00	45.00	164.00	—	300-1000	N110-9001	6
12AD-1	F	N112-1	27.00	47.00	173.00	—	300-1000	N112-9001	2
12AD-2	F	N112-2	41.00	71.00	259.00	—	300-1000	N112-9001	3
12AD-3	F	N112-3	55.00	95.00	346.00	—	300-1000	N112-9001	4
12AD-4	F	N112-4	83.00	142.00	519.00	—	300-1000	N112-9001	6
14AD-1	F	N114-1	73.00	125.00	—	—	200-700	N114-9001	4
14AD-2	F	N114-2	110.00	188.00	—	—	200-700	N114-9001	6
14AD-3	F	N114-3	147.00	251.00	—	—	200-700	N114-9001	8
16AD-1	J	N116-1	100.00	172.00	—	—	200-700	N116-9001	2
16AD-2	J	N116-2	201.00	344.00	—	—	200-700	N116-9001	4
16AD-3	J	N116-3	302.00	516.00	—	—	200-700	N116-9001	6
16AD-4	J	N116-4	402.00	689.00	—	—	200-700	N116-9001	8
19AD-1	BTS	N119-1	521.00	—	—	—	200-500	N119-9001	6
19AD-2	BTS	N119-2	695.00	—	—	—	200-500	N119-9001	8
24AD-1	BTS	N124-1	701.00	—	—	—	50-300	N124-9001	4
24AD-2	BTS	N124-2	1402.00	—	—	—	50-300	N124-9001	8
24AD-3	BTS	N124-3	2103.00	—	—	—	50-300	N124-9001	12
24AD-4	BTS	N124-4	2805.00	—	—	—	50-300	N124-9001	16

* Horsepower ratings listed are based on idle speed as indicated.

For high speed applications, models above 10", or special idle speeds, consult TB Wood's application engineering.

Horsepower ratings listed are based on ideal test conditions. As with all friction clutches, the actual horsepower will vary with application conditions.

Step # 4: Check high speed applications for dynamic balancing and steel band requirements.

Clutch Size	RPM	
	Dynamic Balance Between	Steel Band on Required Output member above
4	4700-11500	5700
6	3200-7600	3900
7	2700-6600	3300
8	2400-5700	2900
10	1900-4600	2300
12	1225-3800	1900
14	1400-3300	1600
16	1200-2900	1400
19	1000-1750	1200
24	900-1600	1000
25	500-1600	1000

NLS® Selection Procedure (continued)

Step # 5: Check bore size and available space envelope.

TYPE A Free Engagement Dimensions in Inches

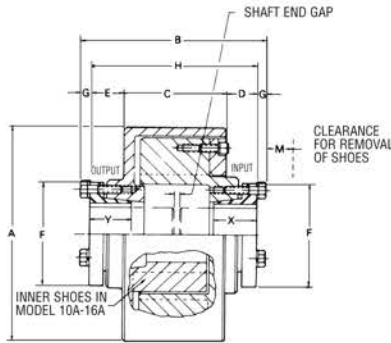

MODELS 4A THRU 16A

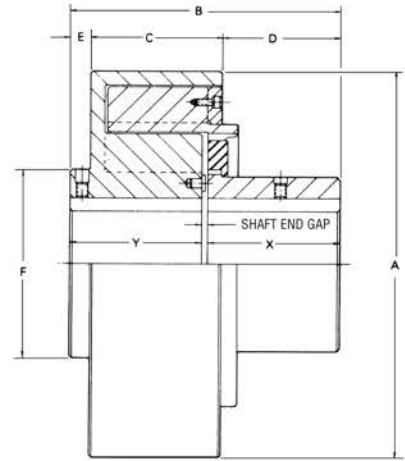

MODELS 19A & 24A

Clutch Size	Sure-Grip Bushing	A	A with Steel Band	B	C	D	E	F	G	H	X	Y	Shaft End Cap		M	B+M	Approx. Wt. Lbs.
													Min	Max			
4A	SH	4-7/16	—	4-13/16	2-1/4	1-1/8	1	2-3/4	1/4	4-3/8	1-1/16	1-1/16	1/16	2	0	4-13/16	8
6A	SDS	6-1/2	7-7/16	5-17/32	3-1/16	15/16	1-1/32	3-1/8	1/4	5-1/32	1-5/16	1-5/16	1/8	2-13/32	13/16	6-11/32	25
7A	SK	7-5/8	8-7/16	7-5/16	3-5/8	1-1/2	1-9/16	3-7/8	5/16	6-11/16	1-15/16	1-15/16	1/8	2-13/16	11/16	8	40
8A	SF	8-3/4	9-7/16	8	4-1/4	1-9/32	1-25/32	4-5/8	11/32	7-5/16	2-1/4	2-1/4	1/8	2-13/16	1-7/8	9-7/8	55
10A	E	10-3/4	11-3/4	10-1/2	4-1/8	3-1/8	2-1/4	6	1/2	9-1/2	3	3	1/8	3-1/2	0	10-1/2	105
12A	F	13	14	11-3/8	5-1/2	3-7/16	1-5/16	6-5/8	9/16	10-1/4	3-15/16	3-15/16	1/8	2-3/8	0	11-3/8	225
14A	F	15	16	11-3/8	5-1/2	3-7/16	1-5/16	6-5/8	9/16	10-1/4	3-15/16	3-15/16	1/8	2-3/8	0	11-3/8	250
16A	J	17-1/4	18-1/4	13-5/8	6-5/8	4-3/16	1-9/16	7-1/4	5/8	12-3/8	4-7/8	4-7/8	1/8	2-5/8	0	13-5/8	400
19A	BTS	20-1/2	21-1/2	14-3/16	6-7/8	6-1/4	1-1/16	10	—	—	7	7	1/8	3/16	0	14-3/16	600
24A	BTS	25-1/2	26-1/2	19-1/16	9-7/8	8	1-1/16	12-1/2	—	—	8-3/4	10	1/8	3/16	0	19-1/16	1225
25A	BTS	—	26-1/2	24-3/16	13-7/8	9-1/4	1-1/16	12-1/2	—	—	10	10	1/8	4-5/64	0	24-3/16	1400

TYPE AD Delayed Engagement Dimensions in Inches

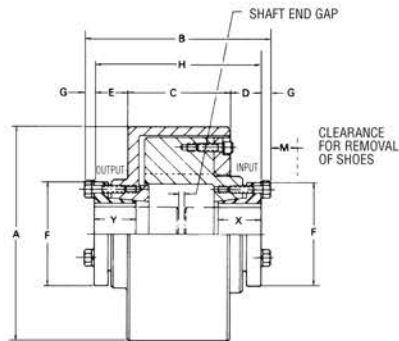

MODELS 4AD THRU 16AD

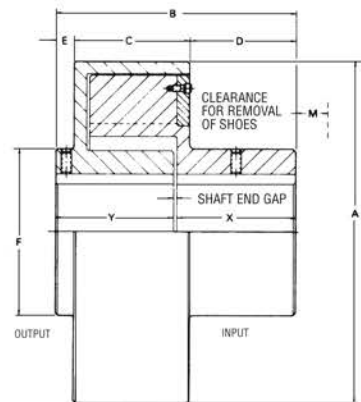

MODELS 19AD & 24AD

Clutch Size	Sure-Grip Bushing	A	A with Steel Band	B	C	D	E	F	G	H	X	Y	Shaft End Cap		M	B+M	Approx. Wt. Lbs.
													Min	Max			
4AD	SH	4-7/16	—	4-13/16	2-1/4	1-1/8	1	2-3/4	1/4	4-3/8	1-1/16	1-1/16	1/16	2	0	4-13/16	8
6AD	SDS	6-1/2	7-7/16	5-17/32	3-1/16	15/16	1-1/32	3-1/8	1/4	5-1/32	1-5/16	1-5/16	1/8	2-13/32	13/16	6-11/32	25
7AD	SK	7-5/8	8-7/16	7-5/16	3-5/8	1-1/2	1-9/16	3-7/8	5/16	6-11/16	1-15/16	1-15/16	1/8	2-13/16	11/16	8	40
8AD	SF	8-3/4	9-7/16	8	4-1/4	1-9/32	1-25/32	4-5/8	11/32	7-5/16	2-1/4	2-1/4	1/8	2-13/16	1-3/8	9-3/8	55
10AD	SF	10-3/4	11-3/4	8-9/16	4-1/8	2	1-3/4	5-1/8	11/32	7-7/8	2-1/4	2-1/4	1/8	3-1/2	11/16	9-1/4	105
12AD	F	13	14	11-3/8	5-1/2	3-7/16	1-5/16	6-5/8	9/16	10-1/4	3-15/16	3-15/16	1/8	2-3/8	5/8	12	215
14AD	F	15	16	11-3/8	5-1/2	2-1/8	1-5/16	6-5/8	9/16	10-1/4	3-15/16	3-15/16	1/8	2-3/8	5/8	12	240
16AD	J	17-1/4	18-1/4	13-5/8	6-5/8	4-3/16	1-9/16	7-1/4	5/8	12-3/8	4-7/8	4-7/8	1/8	2-5/8	5/8	14-1/4	385
19AD	BTS	20-1/2	21-1/2	14-3/16	6-7/8	6-1/4	1-1/16	10	—	—	7	7	1/8	3/16	0	14-3/16	575
24AD	BTS	25-1/2	26-1/2	18-15/16	9-7/8	8	1-1/16	12-1/2	—	—	8-3/4	8-3/4	1/8	1-7/16	0	18-15/16	1175

Bore and keyseat information

Sure Grip Bushing	Bores	Keyseat	Sure Grip Bushing	Bores	Keyseat	Standard Keyseat Dimensions		
						Shaft Dia.	Width	Depth
SH	1/2 - 1-3/8	Standard	E	7/8 - 2-7/8	Standard	1/2 - 9/16	1/8	1/16
	1-7/16 - 1-5/8	3/8 x 1/16		2-15/16 - 3-1/4	3/4 x 1/8	5/8 - 7/8	3/16	3/32
	1-11/16	No K.S.		3-5/16 - 3-1/2	7/8 x 1/16	15/16 - 1-1/4	1/4	1/8
SDS	1/2 - 1-11/16	Standard	F	1 - 3-1/4	Standard	1-5/16 - 1-3/8	5/16	5/32
	1-3/4	3/8 x 1/8		3-5/16 - 3-3/4	7/8 x 3/16	1-7/16 - 1-3/4	3/8	3/16
	1-13/16	1/2 x 1/8		3-13/16 - 3-15/16	1 x 1/8	1-13/16 - 2-1/4	1/2	1/4
	1-7/8 - 1-15/16	1/2 x 1/16		4	No K.S.	2-5/16 - 2-3/4	5/8	5/16
SK	2	No K.S.	J	1-7/16 - 3-13/16	Standard	2-13/16 - 3-1/4	3/4	3/8
	1/2 - 2-1/8	Standard		3-7/8 - 3-15/16	1 x 3/8	3-15/16 - 3-3/4	7/8	7/16
	2-3/16 - 2-1/4	1/2 x 1/8		4 - 4-1/2	1 x 1/8	3-13/16 - 4-1/2	1	1/2
	2-5/16 - 2-1/2	5/8 x 1/16		BTS NLS Models			4-9/16 - 5-1/2	1-1/4
SF	2-9/16 - 2-5/8	No K.S.	Model	Bores	Keyseat	5-9/16 - 6-1/2	1-1/2	3/4
	1/2 - 2-1/4	Standard	19A & 19AD	3 - 5-5/8	Standard	6-9/16 - 7-1/2	1-3/4	3/4
	2-5/16 - 2-1/2	5/8 x 3/16	24A, 25A & 24AD	5-11/16 - 6-5/8	Shallow	7-9/16 - 9	2	3/4
	2-9/16 - 2-3/4	5/8 x 1/16		3-1/4 - 7	Standard			
2-13/16 - 2-15/16	No K.S.		7-1/16 - 8-3/8	Shallow				

NOTE: When installing Sure-Grip bushings follow wrench torque supplied in NLS instructions.

Step # 6: Check clutch capacity for high inertia starts.
If inertia is not known or clutch speed is not listed, see step # 7.

Maximum WR ² (lbs. ft. ²) that may be started at standard motor speeds.							
Clutch	870 RPM	1170 RPM	1750 RPM	Clutch	870 RPM	1170 RPM	1750 RPM
4	500	290	130	14	8000	4700	2100
6	1400	800	350	16	15000	8000	3700
7	2000	1100	510	19	22000	13000	5600
8	3000	1700	790	24	38000	20000	—
10	3800	2100	880	25	47600	26400	—
12	7000	4000	1800				

Step # 7: If inertia is not known or clutch speed is not listed on WR² chart.

ACCELERATION TABLE

Clutch Model No.	Energy Capacity Horsepower-Seconds
4A, 4AD	245
6A, 6AD	680
7A, 7AD	980
8A, 8AD	1,400
10A, 10AD	1,650
12A, 12AD	3,400
14A, 14AD	4,000
16A, 16AD	7,200
19A, 19AD	11,000
24A, 24AD	17,000
25A	25,000
30A	38,000

Maximum allowable acceleration time in seconds can be calculated by dividing the energy capacity in horsepower-seconds by the clutch design horsepower.

If actual acceleration time exceeds the maximum allowable time, a larger clutch should be selected or if the start-up frequency is more than 1 every half-hour.

Example: A 12A-3 is rated at 533 hp @ 1750 with an energy capacity of 3400 Horsepower-seconds

$$\frac{3400 \text{ Horsepower-seconds}}{533 \text{ Horsepower}} = 6.4 \text{ seconds maximum allowable acceleration time without a Steel Band}$$

By adding a Steel Band the acceleration time is increased by 35%
 6.4 x 1.35 = 8.6 seconds with a Steel Band

NLS® Selection Procedure (continued)

Step # 8: Specify the clutch selected.

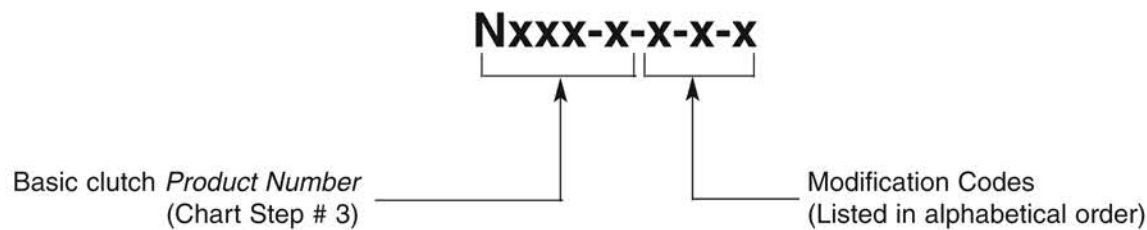

Codes

- B - Dynamic Balance
- L - Limited End Float
- S - Steel Band on Output

Sure-Grip bushings are sold separately.

Ordering examples:

- | | |
|-------------------|--|
| N016-2 | 16A-2 clutch (no modifications) |
| N016-2-B | 16A-2 clutch with dynamic balancing |
| N016-2-S | 16A-2 clutch with steel ring |
| N016-2-B-S | 16A-2 clutch with dynamic balancing and steel ring |
| N016-B-L-S | 16A-2 clutch with dynamic balancing, limited end float, and steel ring |
| J3316 | J Sure-Grip bushing with a 3-3/16 bore |

Note: All NLS clutches use non-asbestos shoe linings.

***From Clutches to Couplings or
Belted Drives to Electronic Controls
TB Wood's Incorporated has the
Power Transmission Components to
Suit Your Needs.***



***With Wood's large range of products and time in the business since
1857, we are able to supply the correct components,
as well as the experience necessary to properly apply them.
For technical assistance on any Wood's product
Call 1-888-TBWOODS***

ROTO-CAM® Manual Clutch

SECTION G2

Features of Roto-Cam

Manually Controlled Cam Operated Clutch

Available in four different types, one to suit your need.

*Cutaway illustration—Model C1
(CA—Type 1) . . . with integral, ball bearing
mounted sheave and direct hand-lever
control. U.S. Patent No. 3,127,969.*

The cam-supported ball bearings incorporated in Roto-Cam Clutches are precision, deep-groove, pre-lubricated, sealed, Conrad-Type, class ABEC-1—with high thrust load capacities . . . no maintenance. The entire load—and only load—on these bearings is the Belleville spring force . . . a constant, controlled, conservative loading . . . assures highly reliable B-10 bearing life values for thousands of hours of operation.

Heavy duty, precision Belleville springs provide the axial force that determines clutch torque capacity—and provide automatic take-up for wear.

Clutch hub is precision-ground, available in various standard bore sizes to fit most gas engine and electric motor shaft sizes. Other bore sizes available on request.

Actuating tabs are a permanent part of the steel cams—providing attachment points for a wide variety of actuating means . . . local manual (as shown)—or with push-pull rods or cables for remote manual or powered actuation . . . completely eliminating separately mounted fulcrums, pivot-points, yokes, trunnions, or loose, rattling levers and links.

Heavy-duty, steel pressure plate is faced with a bonded-on, molded friction lining.

Locking collar provides fully exposed, easily accessible setscrews for locking clutch to shaft and key—without need to disassemble clutch.

High-quality, Belleville separator springs provide fast, positive release between friction members . . . provide an absolute minimum of idling, or neutral drag.

“V” belt sheave is mounted on a heavy-duty, precision, deep-groove, pre-lubricated, sealed, class ABEC-1 ball bearing . . . permits continuous idling—eliminates heat, wear and idling drag.

The steel cams are encircled by a close-fitting, flat garter-type, neoprene seal ring—affixed to the rear cam, but permitting the front cam to slide within the seal ring during actuation . . . positively protecting the cam-and-ball mechanism against entry of dirt, water, or any foreign material . . . permits true “Rolling-Action.”

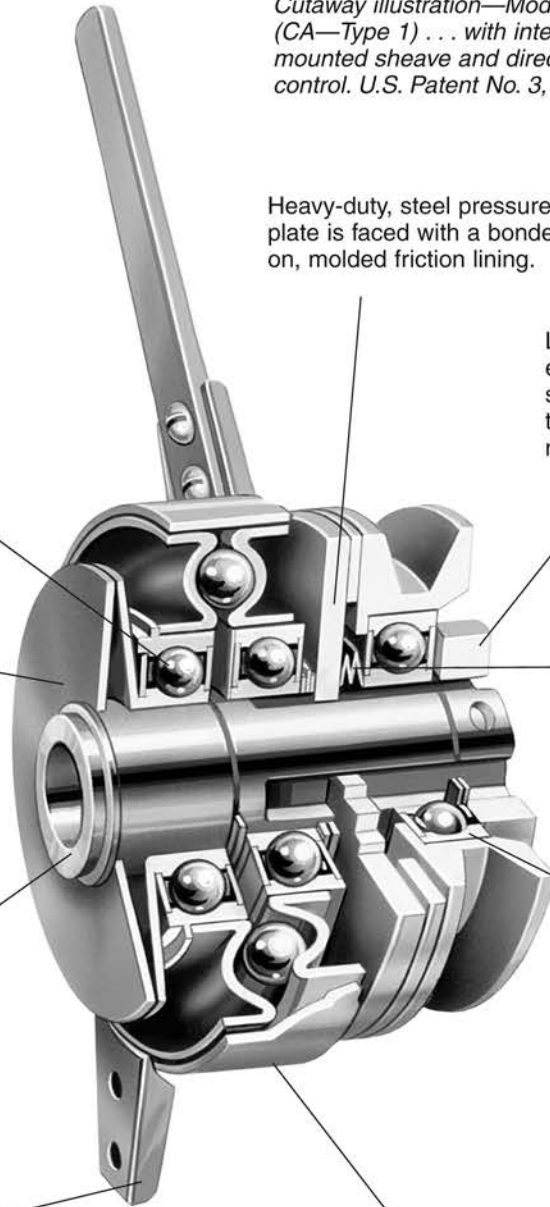





Easy Step by Step Selection Method

Step # 1: Calculate Load Torque.

$$\text{Load Torque (ft. lbs)} = \frac{\text{HP} \times 5250}{\text{RPM}}$$

Step # 2: Select service factor based on prime mover and driven equipment.

DRIVEN EQUIPMENT LOAD CLASSIFICATIONS				
	LIGHT STEADY LOADS Starting torque is equal to or slightly greater than running torque.	MODERATE LOADS High starting torque or above average running torque.	MEDIUM LOADS Starting torque is approximately double running torque.	HEAVY-DUTY LOADS High starting torque, shock loading, light torque reversals during drive.
				
	Centrifugal pumps, uniformly loaded conveyors, light-duty fans and blowers, liquid mixers and agitators, centrifugal compressors and vane type blowers, gear pumps, textile machinery, wood-working machinery.	Machine tools, hot oil pumps, heavy-duty centrifugal pumps cooling towers, slurry agitators, boiler feed pumps, hoists, conveyors.	Dredge pumps, dynamometer drives, light-duty hammermills, lineshafts, paper-converting machinery rotary kilns, rotary or screw-type pumps for high viscosity fluids, paper mill cranes.	Mine ventilating fans, reciprocating pumps or compressors, paper making machinery, heavy-duty hammer-mills, ore crushers, pulverizing mills.
PRIME MOVER				
Steam, gas or air turbine	1.00	1.25	1.50	2.50
AC electric motor	1.25	1.50	1.50	2.50
DC electric motor or DOL start AC electric motor, hydraulic motors	1.25	1.50	1.75	3.00
Gasoline, natural gas, propane or other spark ignition engine	1.75*	1.75*	2.50*	CONSULT ENGINEERING
Diesel	CONSULT ENGINEERING			

* If a type 4 clutch is selected, a hardened drive cup is recommended.

Step # 3: Calculate Design Torque.

$$\text{Design Torque} = \text{Load Torque} \times \text{Service Factor}$$

ROTO-CAM® Selection Procedure (continued)

Step # 4: Determine the most suitable type of clutch.

(see page G2—4 for dimensions)

Type C1

Single-plate with integral bearing-mounted sheave.

Mounting considerations:

Align closely so sheave is not forced against friction plates when disengaged.

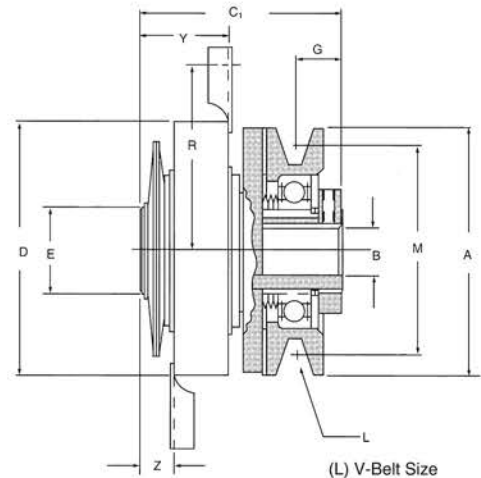

Type C2

Dual-plate with integral bearing-mounted sheave.

Mounting considerations:

Align closely so sheave is not forced against friction plates when disengaged.

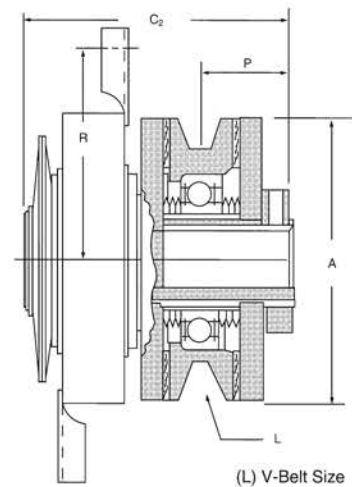

Type C4 (DRY)*

Multiple disc — lugged for use with drive cup.

*Wet units are available upon request
— contact TB Wood's Application Engineering.

Mounting considerations:

The cup and the clutch are to be aligned within .005". When used with a flexible coupling: one half of the coupling should be fastened to the cup and bearing mounted on the clutch shaft as shown. This is done to keep coupling and clutch concentric.

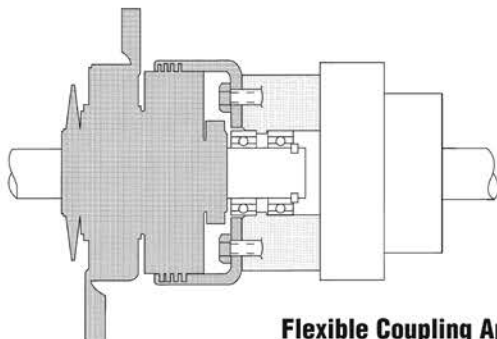

Flexible Coupling Application

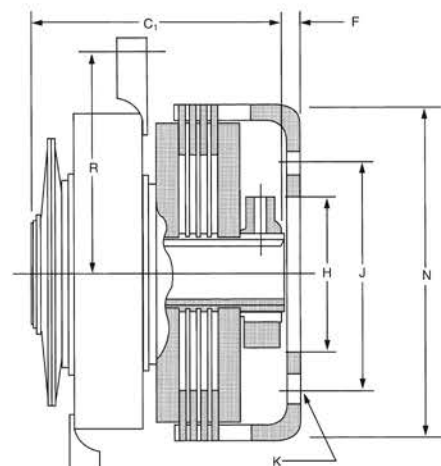

(K) Number and Size Drive Cup Mounting Holes

ROTO-CAM® Selection Procedure (continued)

Type C5

Dual-plate — customer to supply sheave or sprocket

Mounting considerations:

Align closely so sheave or sprocket is not forced against friction plates when disengaged. Customer supplied pulley or sprocket should be square to the bore within .003" and have a surface finish of 30–60 RMS.

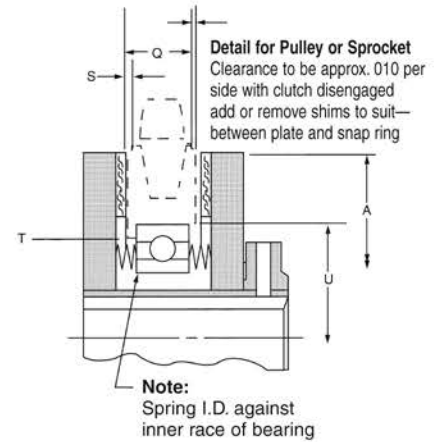
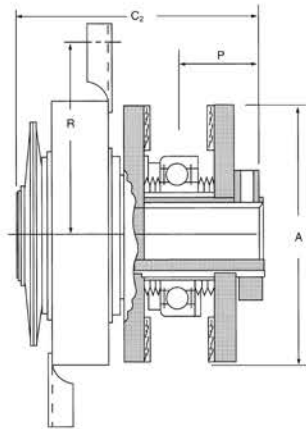

Dimension	Size			
	30	40	45	55
A Diameter	3.00	4.00	4.50	5.50
B1 Rough Bore	0.38	0.50	0.62	0.75
B2 Maximum Bore	0.687	1.000	1.187	1.500
C1 Hub Length	2.62	3.25	3.62	3.89
C2 Hub Length	3.09	3.81	4.18	4.42
D Cam Diameter	3.25	4.25	4.93	5.59
E Hub Diameter	1.00	1.38	1.56	1.98
F Drive Cup Location	0.18	0.25	0.25	0.38
G Pulley Location	0.56	0.75	0.75	0.75
H Drive Cup I.D.	1.377/1.375	1.877/1.875	2.002/2.000	2.504/2.500
J Bolt Circle	2.12	3.00	3.25	3.75
K Hole Qty/Diameter	4/.27	6/.33	6/.33	6/.33
L Sheave Groove	A	AB	AB	AB
M Datum Diameter	2.75-A	3.25-A 3.65-B	3.75-A 4.15-B	4.75-A 5.15-B
N Drive Cup O.D.	3.31	4.38	4.87	6.00
P Sheave Location	1.00	1.31	1.31	1.31
Q Sheave/Sprocket Width	0.69	0.87	0.87	0.87
R Hole Radius	2.41	2.93	3.25	3.69
S Bearing Location	.110/.100	.167/.157	.145/.135	.130/.120
T Diameter	1.69	2.22	2.47	2.91
U Sheave/Sprocket I.D.	1.849/1.850	2.439/2.441	2.675/2.677	3.148/3.150
V Cam Slot Width	0.62	0.75	0.75	0.88
W Hole Location	0.50	0.50	0.50	0.62
X Hole Diameter	0.203	0.266	0.266	0.266
Y Cam Location	1.25	1.50	1.78	1.93
Z Cam Location	0.47	0.69	0.69	0.69

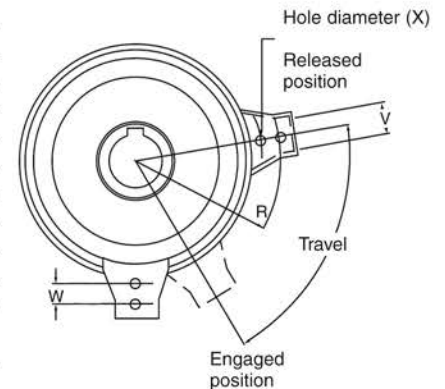

Anchor stationary tab with strap, rod, or pin. This stationary tab must be able to move axially to allow cam operation.

Step # 5: Select clutch size using design torque (step # 3) and clutch type (step # 4).

Clutch Size	Torque Capacity (ft.lbs.)					Engagement Control		Maximum RPM for Engagement	
	TYPE					Lbs. @ R	Degrees of Travel	for Engagement	
	C1	C2	C4 (DRY)	C4 (WET*)	C5			Type 1, 2, & 5	Type 4
30	7.5	15	35	25	15	15	82	6350	5050
40	17	35	75	60	35	25	70	4750	3800
45	25	50	110	90	50	35	70	4200	3350
55	45	90	180	150	90	45	70	3450	2750

ROTO-CAM® Selection Procedure (continued)

Step # 6: Order clutch by the correct product number.

Example:

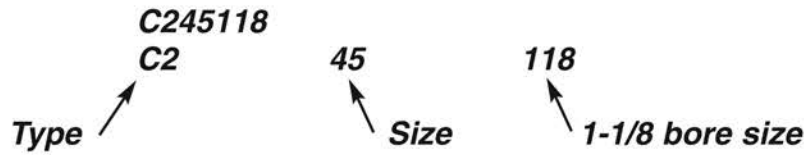

Type 1

Clutch Description	Product Number	Wt. (Lbs.)
C130 x 3/8 RB	C130RB	3.0
C130 x 5/8	C13058	3.0
C140 x 1/2 RB	C140RB	6.0
C140 x 3/4	C14034	6.0
C140 x 7/8	C14078	6.0
C140 x 1	C1401	6.0
C145 x 5/8 RB	C145RB	9.0
C145 x 1	C1451	9.0
C145 x 1-1/8	C145118	9.0
C155 x 3/4 RB	C155RB	12.0
C155 x 1	C1551	12.0
C155 x 1-1/8	C155118	12.0
C155 x 1-1/4	C155114	12.0
C155 x 1-7/16	C1551716	12.0

Type 2

Clutch Description	Product Number	Wt. (Lbs.)
C230 x 3/8 RB	C230RB	4.0
C230 x 5/8	C23058	4.0
C240 x 1/2 RB	C240RB	7.0
C240 x 3/4	C24034	7.0
C240 x 7/8	C24078	7.0
C240 x 1	C2401	7.0
C245 x 5/8 RB	C245RB	10.0
C245 x 7/8	C24578	10.0
C245 x 1	C2451	10.0
C245 x 1-1/8	C245118	10.0
C255 x 3/4 RB	C255RB	14.0
C255 x 1	C2551	14.0
C255 x 1-1/8	C255118	14.0
C255 x 1-1/4	C255114	14.0
C255 x 1-7/16	C2551716	14.0

Type 4

Clutch Description	Product Number	Wt. (Lbs.)
C430 x 3/8 RB	C430RB	4.0
C430 x 5/8	C43058	4.0
C440 x 1/2 RB	C440RB	8.0
C440 x 3/4	C44034	8.0
C440 x 7/8	C44078	8.0
C440 x 1	C4401	8.0
C445 x 5/8 RB	C445RB	11.0
C445 x 1	C4451	11.0
C445 x 1-1/8	C445118	11.0
C455 x 3/4 RB	C455RB	15.0
C455 x 1	C4551	15.0
C455 x 1-1/8	C455118	15.0
C455 x 1-1/4	C455114	15.0
C455 x 1-7/16	C4551716	15.0

Type 5

Clutch Description	Product Number	Wt. (Lbs.)
C530 x 3/8 RB	C530RB	3.0
C530 x 5/8	C53058	3.0
C540 x 1/2 RB	C540RB	6.0
C540 x 3/4	C54034	6.0
C540 x 7/8	C54078	6.0
C540 x 1	C5401	6.0
C545 x 5/8 RB	C545RB	9.0
C545 x 1	C5451	9.0
C545 x 1-1/8	C545118	9.0
C555 x 3/4 RB	C555RB	15.0
C555 x 1	C5551	15.0
C555 x 1-1/8	C555118	15.0
C555 x 1-1/4	C555114	15.0
C555 x 1-7/16	C5551716	15.0

Roto-Cam clutches are supplied with cam tabs in the standard position unless otherwise specified at the time of order. Standard and alternative cam tab positions are shown on this page.

Clutch Size	Cam Location in Degrees			
	A	B	C	D
30	82	30	150	8
40	70	30	150	20
45	70	35	155	15
55	70	30	150	20

Standard Position

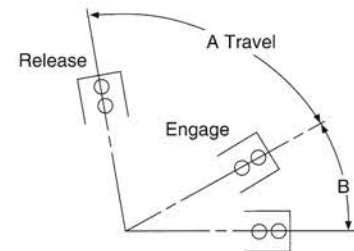

Double Yoke

For double or yoke mounting, as shown, alternate cam Position (A) should be specified.

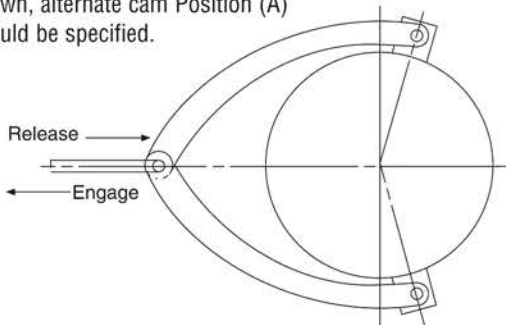

Alternate Position (A)

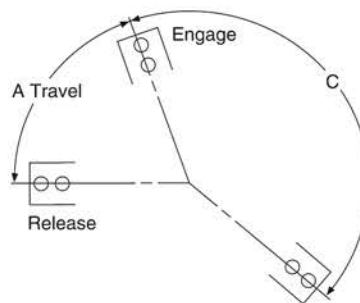

Alternate Position (B)

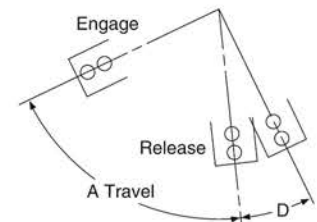

Clutch	Rebuild Kit
C130	C130K
C140	C140K
C145	C145K
C155	C155K
C230	C230K
C240	C240K
C245	C245K
C255	C255K
C430	C430K
C440	C440K
C445	C445K
C455	C455K
C530	C230K
C540	C240K
C545	C245K
C555	C255K

Rebuild kits consist of:

Replacement friction disc
Separator disc
Belleville springs
Snap rings

C4 kits rebuild dry and wet units

Applications

Wood's Roto-Cam Clutches are used on a wide range of applications. With either gas engines or electric motors as the prime mover they see uses on conveyors, pumps, generator sets and agricultural equipment.

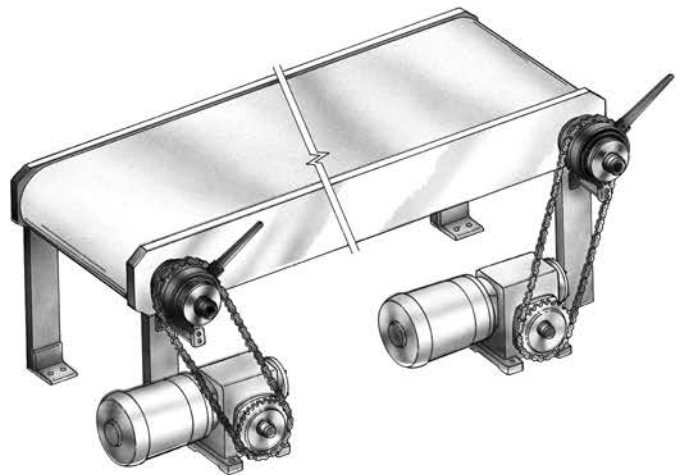
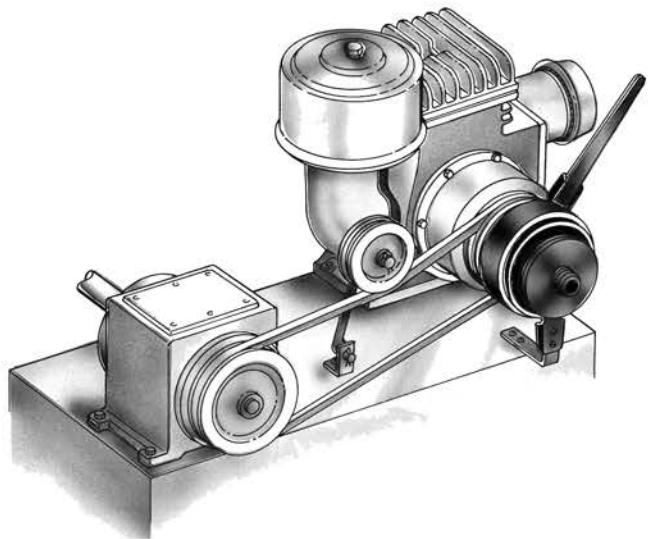

DISC-O-TORQUE® Hydraulic Clutches

SECTION G3

Careful selection of highest-quality materials, precision manufacturing by experienced craftsmen, conscientious assembly, and rigid inspection—all are important Value-Factors that ensure long-life, trouble-free, maintenance-free performance—readily apparent upon examining and operating a Model D2 Clutch.

- Maximum torque
- Minimum size
- Absorbs maximum energy
- Self-contained
- Minimum idle resistance
- Smooth, fast response
- Low installation costs
- Predictable life
- Uniform performance

Wood's Fluid-Actuated Clutches are your best choice. Whether your application calls for "wet" or "dry" operation; hydraulic or pneumatic actuation; stationary or rotating cylinders; you can specify it from Wood's usually right from this catalog.

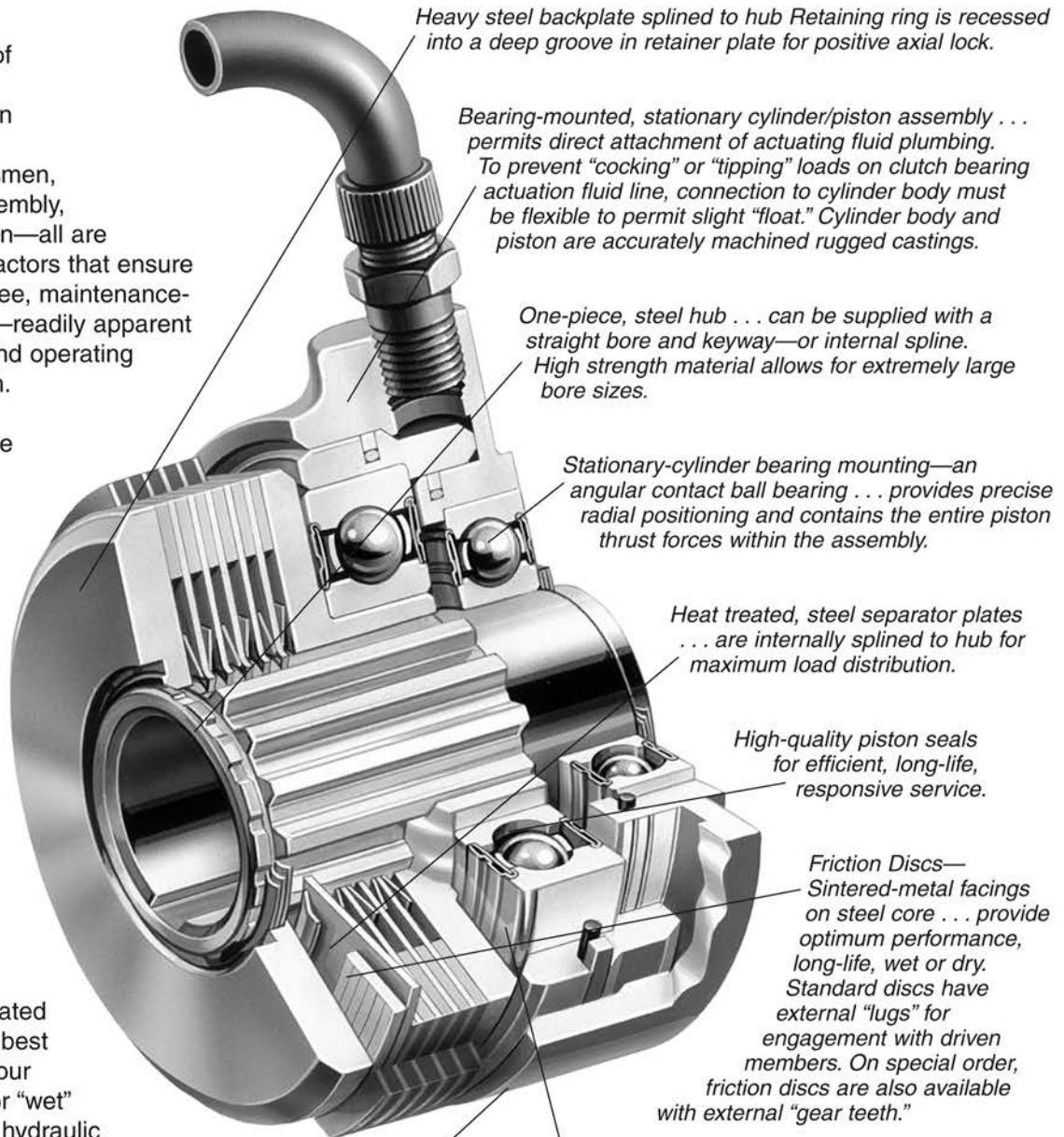

Heavy steel backplate splined to hub Retaining ring is recessed into a deep groove in retainer plate for positive axial lock.

Bearing-mounted, stationary cylinder/piston assembly . . . permits direct attachment of actuating fluid plumbing. To prevent "cocking" or "tipping" loads on clutch bearing actuation fluid line, connection to cylinder body must be flexible to permit slight "float." Cylinder body and piston are accurately machined rugged castings.

One-piece, steel hub . . . can be supplied with a straight bore and keyway—or internal spline. High strength material allows for extremely large bore sizes.

Stationary-cylinder bearing mounting—an angular contact ball bearing . . . provides precise radial positioning and contains the entire piston thrust forces within the assembly.

Heat treated, steel separator plates . . . are internally splined to hub for maximum load distribution.

High-quality piston seals for efficient, long-life, responsive service.

Friction Discs—Sintered-metal facings on steel core . . . provide optimum performance, long-life, wet or dry. Standard discs have external "lugs" for engagement with driven members. On special order, friction discs are also available with external "gear teeth."

Precision roller thrust bearing carries only piston thrust and provides the reaction between the precision disc pack and the pressurized piston cylinder assembly.

Auxiliary Lube Port

Positive lubrication is provided by a separate system which provides for a continuous flow of lubricant for bearing cooling, lubricity and separation of actuating fluid and lubricant. If an external lubrication source is available or if actuating fluid is to be used for lubrication, either can be readily accommodated by standard catalog models.





DISC-O-TORQUE® Selection Procedure

Easy Step by Step Selection Method

Step # 1: Calculate Load Torque.

$$\text{Load Torque (ft. lbs)} = \frac{\text{HP} \times 5250}{\text{RPM}}$$

Step # 2: Select service factor based on prime mover and driven equipment.

DRIVEN EQUIPMENT LOAD CLASSIFICATIONS				
	LIGHT STEADY LOADS Starting torque is equal to or slightly greater than running torque	MODERATE LOADS High starting torque or above average running torque.	MEDIUM LOADS Starting torque is approximately double running torque.	HEAVY-DUTY LOADS High starting torque, shock loading, light torque reversals during drive.
				
	Centrifugal pumps, uniformly loaded conveyors, light-duty fans and blowers, liquid mixers and agitators, centrifugal compressors, lobe and vane type blowers, gear pumps, textile machinery, wood-working machinery.	Machine tools, hot oil pumps, heavy-duty centrifugal pumps cooling towers, slurry agitators, boiler feed pumps, hoists, conveyors.	Dredge pumps, dynamometer drives, light-duty hammermills, lineshafts, paper-converting machinery rotary kilns, rotary or screw-type pumps for high viscosity fluids, paper mill cranes.	Mine ventilating fans, reciprocating pumps or compressors, paper making machinery, heavy-duty hammer-mills, ore crushers, pulverizing mills.
PRIME MOVER				
Steam, gas or air turbine	1.00	1.25	1.50	2.50
AC electric motor	1.25	1.50	1.50	2.50
DC electric motor or DOL start AC electric motor, hydraulic motors	1.25	1.50	1.75	3.00
Gasoline, natural gas, propane or other spark ignition engine	1.75	1.75	2.50	CONSULT ENGINEERING
Diesel*	2.50	CONSULT ENGINEERING		

* Gear tooth friction discs may be required, consult Wood's.

Step # 3: Calculate Design Torque.

$$\text{Design Torque} = \text{Load Torque} \times \text{Service Factor}$$

DISC-O-TORQUE® Selection Procedure (continued)

Step # 4: Determine the most suitable clutch type.

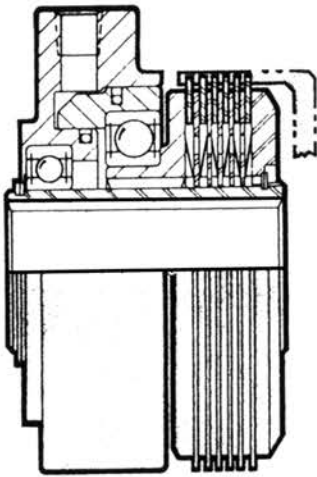

Type D2

This unit is designed with prelubricated bearings which are sealed. This “dry” assembly requires no further lubrication. This type may be actuated with air or oil from stock.

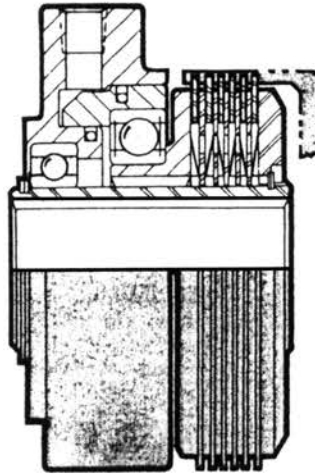

Type D3

This unit requires external lubrication in order to keep the bearings and friction disc cool. The friction disc requires splash or spray lubrication to comply with catalog ratings. The bearings should be lubed by spray, splash, or direct means.

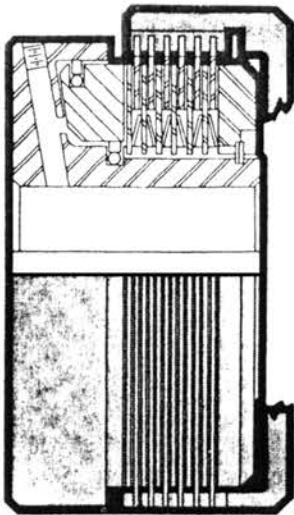

Type D4

Actuation oil, on this type, is supplied thru the shaft rather than external porting. This eliminates the need for bearings, and allows the unit to be more compact. The torque capacity of this compact unit is extremely high.

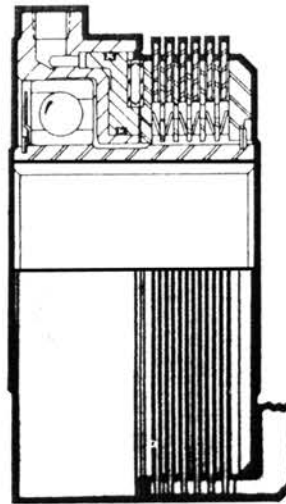

Type D5

This type has a separate port for direct continuous lubrication of the bearings. External spray or splash lubrication of the friction disc is required. This type is primarily utilized in transmission cases.

DISC-O-TORQUE® Selection Procedure (continued)

Step # 5: Using the charts below determine the clutch size.

Use design torque (step 3) and your available actuating pressure
 Design torque and actuating pressure should intersect at or below the correct size.

Type D2

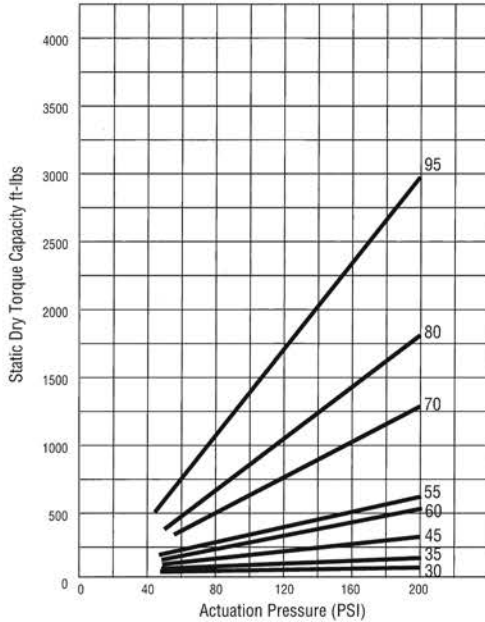

Type D3

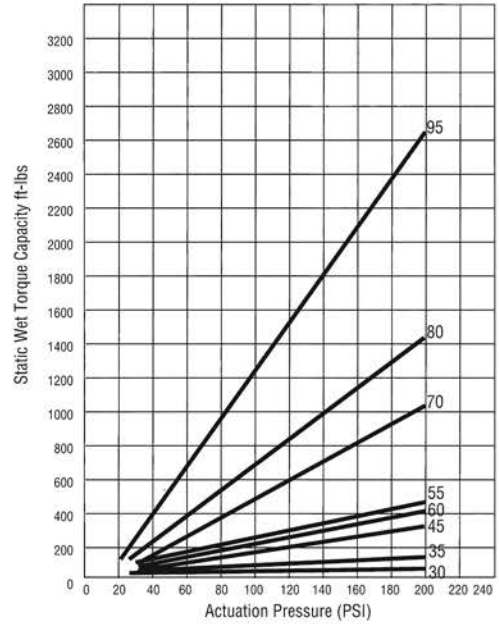

Type D4

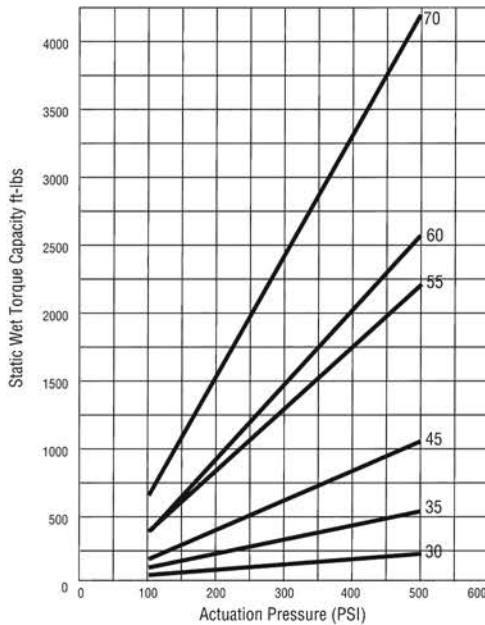

Type D5

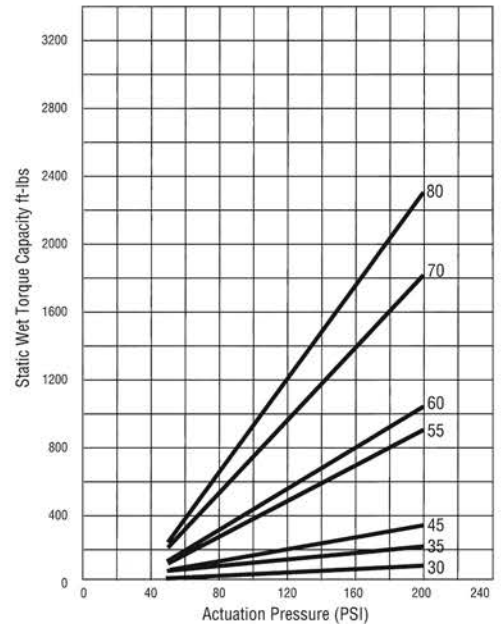

Static Torque is when the clutch is fully engaged. Dynamic torque is prior to full engagement and “lock-up.” The relationship between dynamic and static torque can be seen in step #7.

DISC-O-TORQUE® Selection Procedure (continued)

Step # 6: Verify the clutch energy capacity.

$$KE = .00017 \times (WR^2c) \times (Ni^2 - Nf^2) \text{ ft.lbs./cycle}$$

.00017 = constant WR^2c = Inertia @ clutch (lbs. ft²)
 Ni = Initial RPM Nf = Final RPM

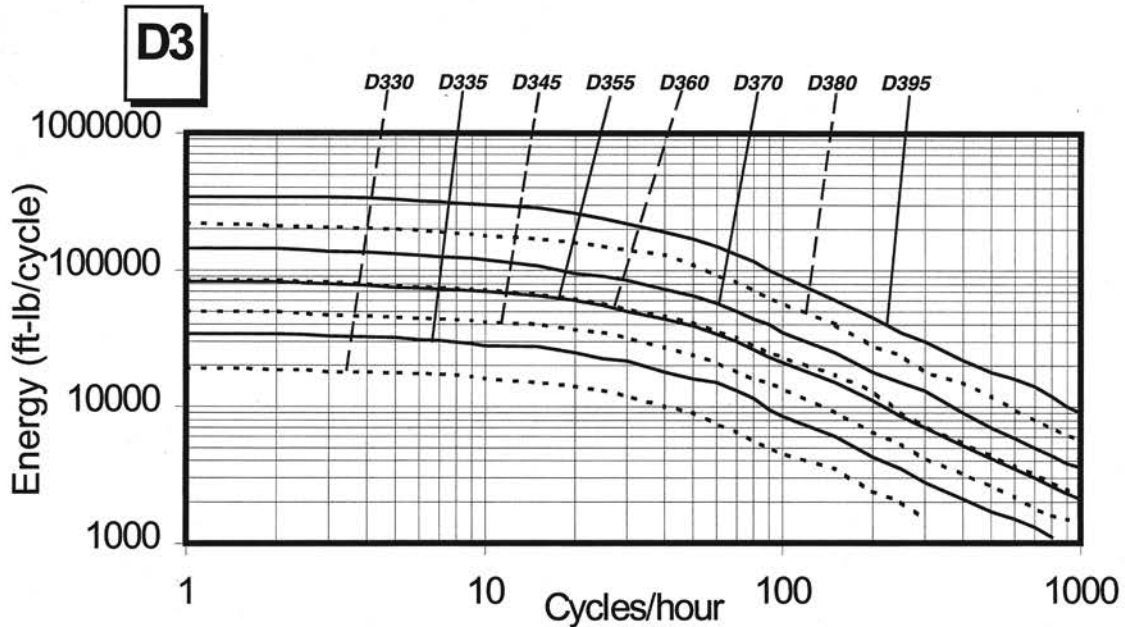
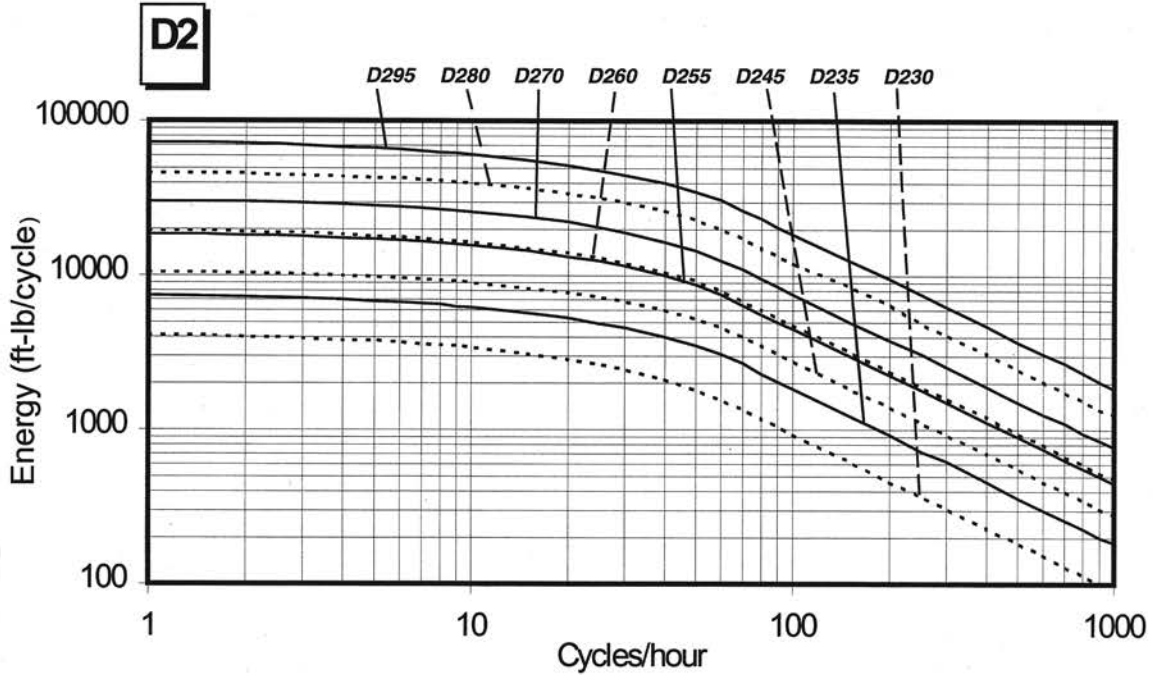

The cooling rates represented by the curves are based on an external lubrication flow of 1.0 gallon per minute through the disc pack.

DISC-O-TORQUE® Selection Procedure (continued)

If the clutch rotates at a speed different than the driven machine, the inertia (WR^2) of the driven machine relative to the clutch may be calculated as follows.

$$WR^2_c = WR^2_{dn} \times (RPM_{dn} / RPM_c)^2$$

WR^2_c = Inertia @ clutch (lbs. ft ²)	RPM_c = rpm @ clutch
WR^2_{dn} = Inertia @ driven machine (lbs. ft ²)	RPM_{dn} = rpm @ driven machine

If the intersection of the KE value and the number of cycles per hour is at or below the clutch selected in step 5 the selection is correct. If the intersection is above the line, reselect a larger clutch based on these charts.

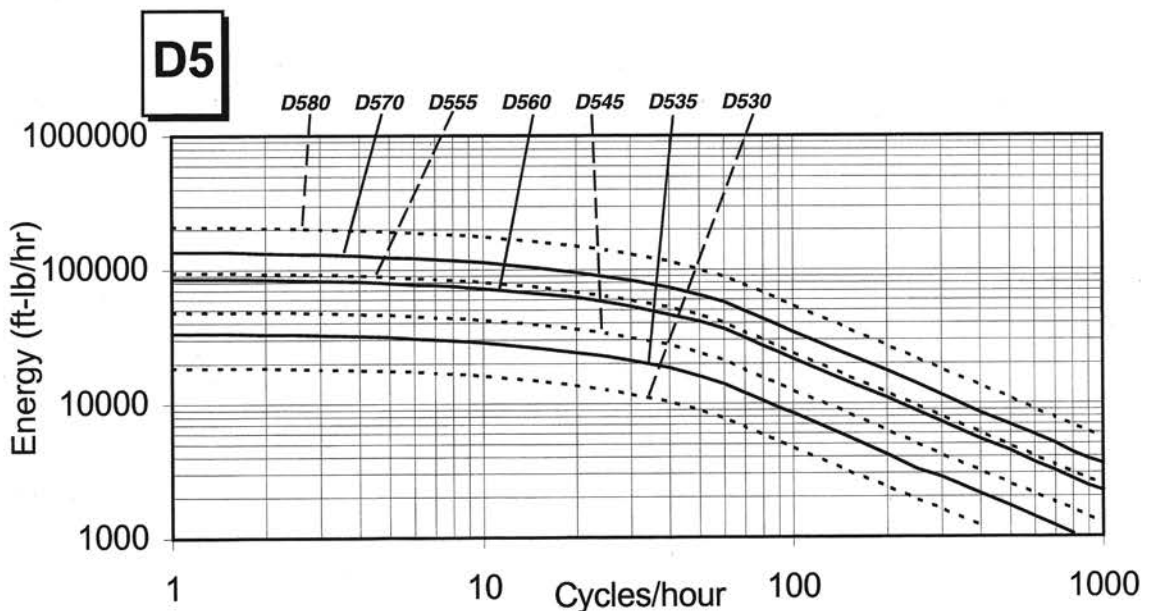
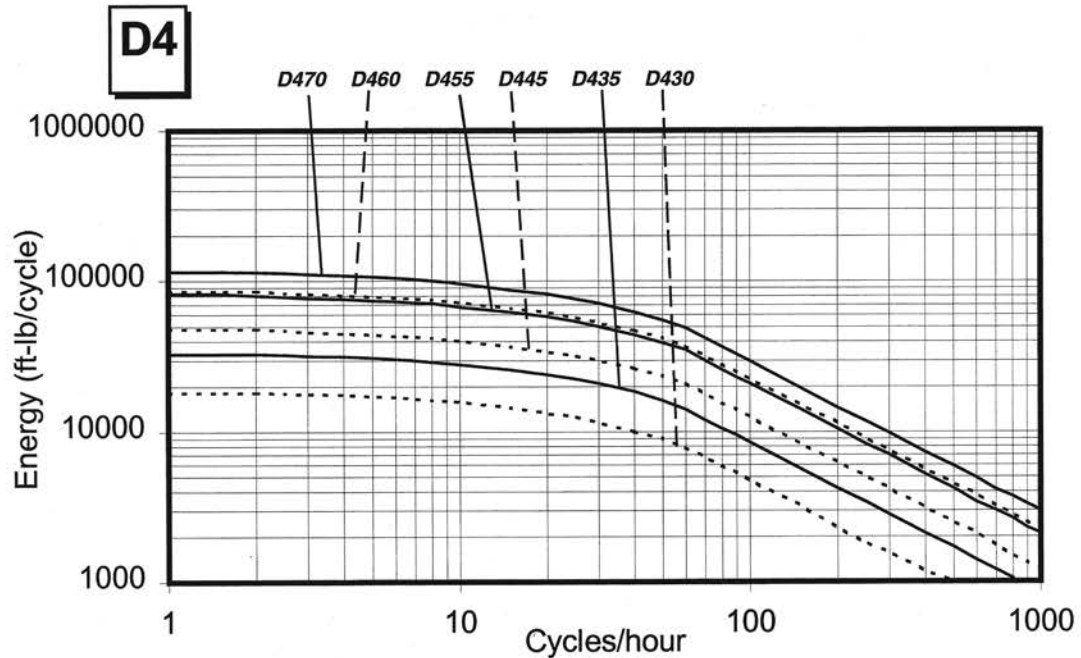

DISC-O-TORQUE® Selection Procedure (continued)

Step # 7: Check clutch dimensions to verify fit in application space envelope.

D2 & D3 DIMENSIONS

		30	35	45	55	60	70	80	95
A	Body O.D.	3.38	3.94	4.88	6	6.56	7.56	8.62	10.38
A1	Boss Height	2.50	2.75	3.19	3.75	4	4.44	4.94	5.62
A2	Boss Width	0.88	0.88	0.88	0.88	1	1	1	1
A3	Cylinder Diameter	2.56	3.12	3.62	4.50	5.00	5.75	6.62	7.75
B	Axial Length	2.625	2.875	3.317	3.517	3.940	4.380	4.825	6.005
C	Cylinder Width	1.19	1.25	1.41	1.62	1.69	1.75	2.03	2.56
C1	Hub Extension	0.31	0.44	0.38	0.34	0.44	0.56	0.44	0.34
C2	Port Location	0.75	0.88	0.88	0.81	0.94	1.06	1.12	1.16
D	Hub O.D. (rear)	1.19	1.56	2	2.56	2.94	3.34	3.94	4.72
E	Hub O.D. (front)	1.33	1.50	2.12	2.69	3.06	3.55	4	4.75
F	Disc Minor O.D.	3	3.50	4.50	5.50	6	7	8	9.50
G	Disc Major O.D.	3.31	3.81	4.88	6	6.56	7.62	8.62	*
H	Disc Lug Width	0.734	0.734	0.796	0.609	0.609	0.734	0.734	*
J	No. of Lugs	6	6	6	12	12	12	12	*
K	No. of Disc	6	6	6	6	6	7	7	7
N	Slot Width	0.750	0.750	0.812	0.625	0.625	0.750	0.750	*
R	Engagement Length	0.964	1.0	1.225	1.350	1.525	1.765	1.906	2.680
T	Gap to Drive Cup	0.106	0.160	0.145	0.300	0.145	0.075	0.114	0.350

		30	35	45	55	60	70	80	95
D2	Dynamic torque dry @ 150 PSI	67 ft. lbs.	104 ft. lbs.	210 ft. lbs.	380 ft. lbs.	348 ft. lbs.	771 ft. lbs.	1080 ft. lbs.	1776 ft. lbs.
	Static torque dry @ 150 PSI	80 ft. lbs.	124 ft. lbs.	251 ft. lbs.	455 ft. lbs.	417 ft. lbs.	923 ft. lbs.	1294 ft. lbs.	2125 ft. lbs.
D3	Dynamic torque wet @ 150 PSI	49 ft. lbs.	77 ft. lbs.	155 ft. lbs.	281 ft. lbs.	257 ft. lbs.	570 ft. lbs.	798 ft. lbs.	1383 ft. lbs.
	Static torque wet @ 150 PSI	65 ft. lbs.	101 ft. lbs.	205 ft. lbs.	371 ft. lbs.	340 ft. lbs.	753 ft. lbs.	1055 ft. lbs.	1966 ft. lbs.
MAX BORE		.875	1.125	1.500	2.000	2.375	2.625	3.250	3.875

Rated up to 200 PSI. For other actuation pressures, refer to Chart in Step #5.

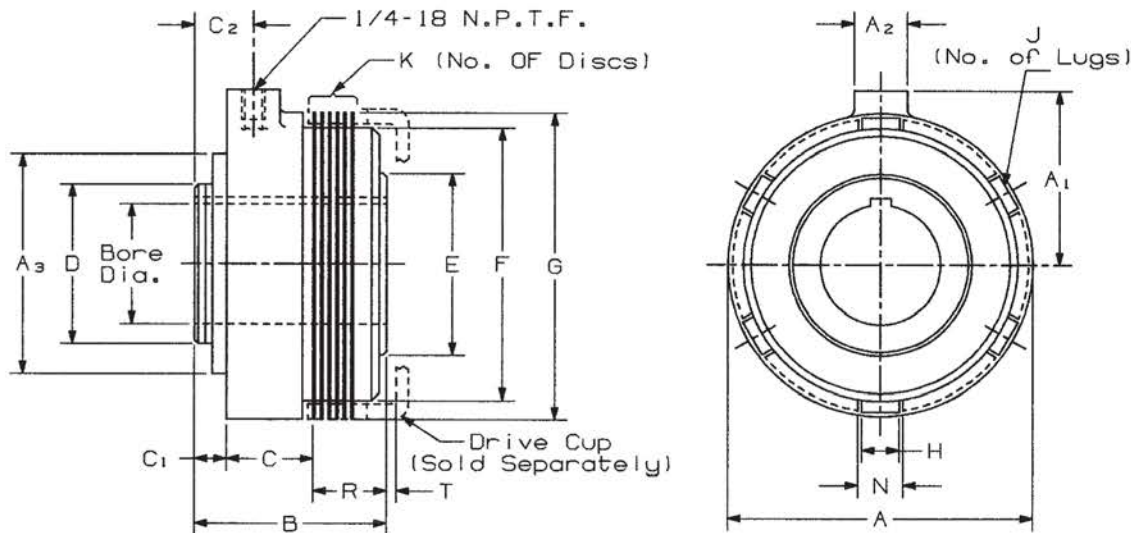

DISC-O-TORQUE® Selection Procedure (continued)

D4 DIMENSIONS

		30	35	45	55	60	70
A	Body O.D.	3.38	3.81	4.88	6	6.56	7.62
B	Axial Length	1.880	27	2.320	2.745	2.780	3.132
C	Cylinder Width	0.84	0.84	0.96	1	1.06	1.14
C1	Port Location	See Product Number Listing (STEP #8)					
D	Hub O.D. (rear)	1.88	2	2.75	3.12	3.62	4
E	Disc Minor O.D.	3	3.50	4.50	5.50	6	7
F	Disc Major O.D.	3.31	3.81	4.88	6	6.56	7.62
G	Disc Lug Width	0.734	0.734	0.796	0.609	0.609	0.734
H	No. of Lugs	6	6	6	12	12	12
J	No. of Disc	6	6	6	6	6	6
N	Slot Width	0.750	0.750	0.812	0.625	0.625	0.750
R	Engagement Length	0.977	1.065	1.245	1.562	1.575	1.775
T	Gap to Drive Cup	0.093	0.095	0.125	0.089	0.095	0.065

		30	35	45	55	60	70
D4	Dynamic torque wet @ 150 PSI	50 ft. lbs.	101 ft. lbs.	188 ft. lbs.	449 ft. lbs.	466 ft. lbs.	816 ft. lbs.
	Static torque wet @150 PSI	66 ft. lbs.	134 ft. lbs.	249 ft. lbs.	594 ft. lbs.	617 ft. lbs.	1080 ft. lbs.
MAX BORE		1.312	1.500	2.125	2.4375	2.9375	3.250

Rated up to 500 PSI. For other actuation pressures, refer to Chart in Step #5.

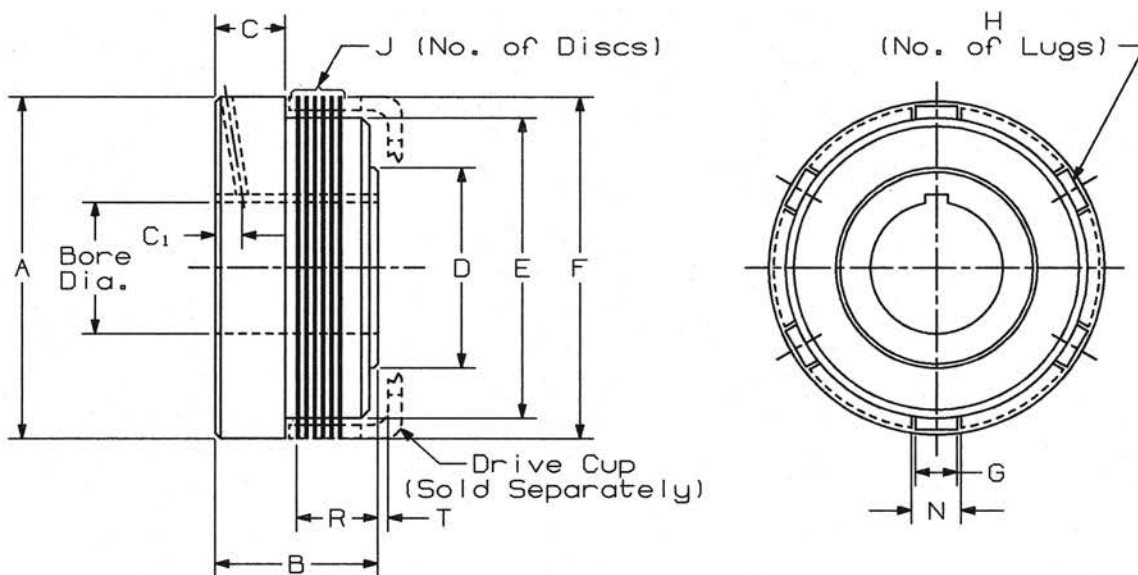

DISC-O-TORQUE® Selection Procedure (continued)

D5 DIMENSIONS

		30	35	45	55	60	70	80
A	Body O.D.	3.31	3.94	4.88	6	6.56	7.75	8.62
A1	Boss Height	2.03	2.34	2.81	3.38	3.69	4.19	4.69
A2	Boss Diameter	0.88	0.88	0.88	0.88	0.88	1.00	1.00
B	Axial Length	2.265	2.385	2.880	3.260	3.445	3.785	4.160
C	Cylinder Width	1.19	1.25	1.44	1.59	1.72	1.81	2.09
C1	Port Location	0.44	0.50	0.44	0.50	0.50	0.56	0.56
C2	Hub Extension	0.03	0.03	0.03	0.03	0.03	0.09	0.03
C3	Lube Port Location	0.44	0.50	0.44	0.50	0.50	0.56	0.69
a°	Lube Port Location	30	30	30	30	15	15	15
D	Hub O.D. (rear)	1.56	1.97	2.56	2.95	3.53	4.12	4.72
E	Hub O.D. (front)	1.94	2.02	2.75	3.09	3.62	4.00	4.75
F	Disc Minor O.D.	3	3.50	4.50	5.50	6.00	7.00	8.00
G	Disc Major O.D.	3.31	3.94	4.88	6.00	6.56	7.62	8.62
H	Disc Lug Width	0.734	0.734	0.796	0.609	0.609	0.734	0.734
J	No. of Lugs	6	6	6	12	12	12	12
K	No. of Disc	6	6	6	7	6	7	7
N	Slot Width	0.750	0.750	0.812	0.625	0.625	0.750	0.750
R	Engagement Length	0.922	1.0	1.225	1.452	1.525	1.706	1.875
T	Gap to Drive Cup	0.148	0.160	0.145	0.198	0.145	0.075	0.145

		30	35	45	55	60	70	80
D5	Dynamic torque wet @ 150 PSI	72 ft. lbs.	125 ft. lbs.	227 ft. lbs.	530 ft. lbs.	587 ft. lbs.	985 ft. lbs.	1250 ft. lbs.
	Static torque wet @150 PSI	95 ft. lbs.	165 ft. lbs.	300 ft. lbs.	700 ft. lbs.	775 ft. lbs.	1300 ft. lbs.	1650 ft. lbs.
MAX BORE		1.250	1.500	2.000	2.375	3.000	3.250	3.875

Rated up to 200 PSI. For other actuation pressures, refer to Chart in Step #5.

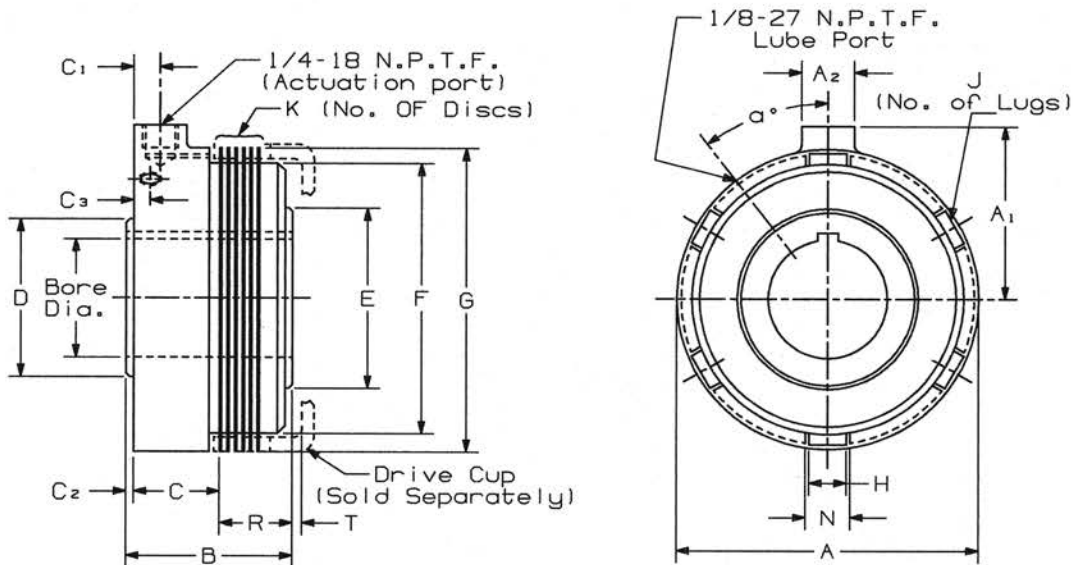

DISC-O-TORQUE® Selection Procedure (continued)

Drive Cup Dimensions

Used with all clutch types. - Sold separately

Drive cups are normally supplied slotted for engagement with the lugs of the friction disc, however on special order the disc and drive cup can be made with gear teeth for driving. The K dimension indicates the number of gear teeth on these units.

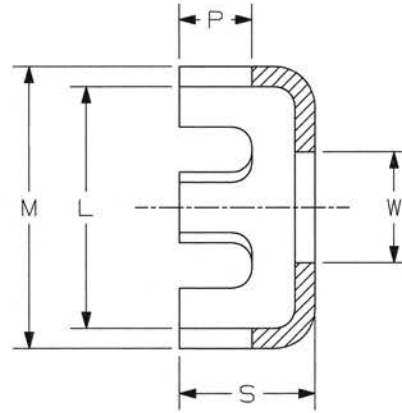

		30	35	45	55	60	70	80	95
L	I.D.	3.062	3.562	4.562	5.562	6.062	7.062	8.062	*
M	O.D.	3.310	3.880	4.880	5.940	6.560	7.690	8.690	*
P	Slot Length	0.840	0.890	1.000	1.270	1.280	1.410	1.530	*
S	Cup Length	1.250	1.380	1.650	1.960	2.050	2.220	2.400	3.370
W	Min. Cup Bore	1.000	1.000	1.000	1.500	2.000	2.000	2.500	3.500
K	No. Teeth (Gear Type)	33	38	48	58	63	73	83	119

Step # 8: Ordering clutch and drive cup.

Drive Cup: (MUST BE ORDERED SEPARATELY)

The drive cups are the same for all clutch types. For hardened or gear style drive cup consult Wood's.

SIZE	DRIVE CUP Product No.
30	D530DC
35	D535DC
45	D545DC
55	D555DC

SIZE	DRIVE CUP Product No.
60	D560DC
70	D570DC
80	D580DC
95	Consult Wood's

On D4 clutches with activation pressures above 300 PSI, a gear style drive cup is recommended.

Order example: For a D355 clutch drive cup order **D555DC**

Clutch:

Product number break down

For a **D460 X 2-1/4** order **D460214**



Additional ordering considerations:

Type D5 clutches are available with the following bearing lube options.

Lube Type I - For lubricating the bearings with the axiliary lube port. (standard)

Lube Type II - For lubricating the needle thrust bearing only with actuating fluid. The angular contact bearing must be lubricated by external spray, mist or splash.

Lube Type III - Bearing lubrication not using Type I or II, but using an external spray mist or splash.

Lube Type IV - For application using Type I and II above for lubrication.

When ordering a D5 clutch note your Lube Type.

DISC-O-TORQUE® Product Numbers

D2		
Clutch Description	Product Number	Wt. Lbs.
D230 X 1/2 RB	D230RB	4.0
D230 X 5/8	D23058	4.0
D230 X 3/4	D23034	4.0
D235 X 5/8 RB	D235RB	6.0
D235 X 7/8	D23578	6.0
D235 X 1	D2351	6.0
D245 X 7/8 RB	D245RB	11.0
D245 X 1-1/8	D245118	11.0
D245 X 1-1/4	D245114	11.0
D255 X 1-1/8 RB	D255RB	18.0
D255 X 1-1/2	D255112	18.0
D255 X 1-5/8	D255158	18.0
D255 X 1-3/4	D255134	18.0
D260 X 1-1/4 RB	D260RB	25.0
D260 X 2	D2602	25.0
D260 X 2-1/8	D260218	25.0
D270 X 1-1/2 RB	D270RB	34.0
D270 X 2-1/4	D270214	34.0
D270 X 2-1/2	D270212	34.0
D280 X 1-7/8 RB	D280RB	49.0
D280 X 2-3/4	D280234	49.0
D280 X 3	D2803	49.0
D295 - SPECIAL ORDER ONLY		60.0

D3		
Clutch Description	Product Number	Wt. Lbs.
D330 X 1/2 RB	D330RB	4.0
D330 X 5/8	D33058	4.0
D330 X 3/4	D33034	4.0
D335 X 5/8 RB	D335RB	6.0
D335 X 7/8	D33578	6.0
D335 X 1	D3351	6.0
D345 X 7/8 RB	D345RB	11.0
D345 X 1-1/8	D345118	11.0
D345 X 1-1/4	D345114	11.0
D355 X 1-1/8 RB	D355RB	18.0
D355 X 1-1/2	D355112	18.0
D355 X 1-5/8	D355158	18.0
D355 X 1-3/4	D355134	18.0
D360 X 1-1/4 RB	D360RB	25.0
D360 X 2	D3602	25.0
D360 X 2-1/8	D360218	25.0
D370 X 1-1/2 RB	D370RB	34.0
D370 X 2-1/4	D370214	34.0
D370 X 2-1/2	D370212	34.0
D380 X 1-7/8 RB	D380RB	49.0
D380 X 2-3/4	D380234	49.0
D380 X 3	D3803	49.0
D395 - SPECIAL ORDER ONLY		60.0

DISC-O-TORQUE DESIGNATOR CHART

NEW	OLD
D2	STD
D3	STH
D4	RO
D5	HTH

D4			
Clutch Description	Product Number	Wt. Lbs.	C1 Dim.
D430 X 3/4 RB	D430RB	3.5	0.410
D430 X 7/8	D43078	3.5	0.394
D430 X 1	D4301	3.5	0.382
D430 X 1-1/8	D430118	3.5	0.370
D435 X 1 RB	D435RB	5.0	0.380
D435 X 1-1/8	D435118	5.0	0.373
D435 X 1-1/4	D435114	5.0	0.364
D435 X 1-3/8	D435138	5.0	0.354
D445 X 1-1/4 RB	D445RB	9.0	0.500
D445 X 1-3/8	D445138	9.0	0.486
D445 X 1-1/2	D445112	9.0	0.476
D445 X 1-5/8	D445158	9.0	0.460
D445 X 1-3/4	D445134	9.0	0.452
D455 X 1-1/2 RB	D455RB	16.0	0.580
D455 X 1-3/4	D455134	16.0	0.563
D455 X 1-7/8	D455178	16.0	0.547
D455 X 2	D4552	16.0	0.537
D455 X 2-1/4	D455214	16.0	0.515
D460 X 1-1/2 RB	D460RB	20.0	0.630
D460 X 2-1/4	D460214	20.0	0.563
D460 X 2-3/8	D460238	20.0	0.553
D460 X 2-1/2	D460212	20.0	0.543
D460 X 2-3/4	D460234	20.0	0.524
D470 X 1-3/4 RB	D470RB	29.0	0.700
D470 X 2-1/2	D470212	29.0	0.645
D470 X 2-5/8	D470258	29.0	0.625
D470 X 2-3/4	D470234	29.0	0.610
D470 X 3	D4703	29.0	0.591

D5		
Clutch Description	Product Number	Wt. Lbs.
D530 X 1/2 RB	D530RB	4.0
D530 X 7/8	D53078	4.0
D530 X 1	D5301	4.0
D535 X 5/8 RB	D535RB	6.5
D535 X 1-1/8	D535118	6.5
D535 X 1-1/4	D535114	6.5
D545 X 7/8 RB	D545RB	12.0
D545 X 1-1/2	D545112	12.0
D545 X 1-3/4	D545134	12.0
D555 X 1-1/8 RB	D555RB	19.0
D555 X 1-7/8	D555178	19.0
D555 X 2	D5552	19.0
D560 X 1-1/4 RB	D560RB	25.0
D560 X 2	D5602	25.0
D560 X 2-1/4	D560214	25.0
D560 X 2-1/2	D560212	25.0
D570 X 1-3/4 RB	D570RB	35.0
D570 X 2-1/2	D570212	35.0
D570 X 2-3/4	D570234	35.0
D580 X 1-7/8 RB	D580RB	51.0
D580 X 2-3/4	D580234	51.0
D580 X 3	D5803	51.0

Wood's welcomes the making of specials and modification of stock to meet your application needs.

Clutch	Disc Kit	Seal Kit	Bearing Kit
D230	D230DK	D230SK	D230BK
D235	D235DK	D235SK	D235BK
D245	D245DK	D245SK	D245BK
D255	D255DK	D255SK	D255BK
D260	D260DK	D260SK	D260BK
D270	D270DK	D270SK	D270BK
D280	D280DK	D280SK	D280BK
D295	D295DK	D295SK	D295BK
D330	D230DK	D230SK	D330BK
D335	D235DK	D235SK	D335BK
D345	D245DK	D245SK	D345BK
D355	D255DK	D255SK	D355BK
D360	D260DK	D260SK	D360BK
D370	D270DK	D270SK	D370BK
D380	D280DK	D280SK	D380BK
D395	D295DK	D295SK	D395BK
D430	D430DK	D430SK	N/A
D435	D435DK	D435SK	N/A
D445	D445DK	D445SK	N/A
D455	D455DK	D455SK	N/A
D460	D460DK	D460SK	N/A
D470	D470DK	D470SK	N/A
D530	D530DK	D530SK	D530BK
D535	D535DK	D535SK	D535BK
D545	D545DK	D545SK	D545BK
D555	D555DK	D555SK	D555BK
D560	D560DK	D560SK	D560BK
D570	D570DK	D570SK	D570BK
D580	D580DK	D580SK	D580BK

Kits contain enough parts to repair one clutch.

Disc Kit - (Formerly RK1)

CONTENTS :

Friction Disc
Separating Disc
Separator Spring
Snap Rings

Seal Kit - (Formerly RK2)

CONTENTS :

Piston Rings
O-Rings

Bearing Kit - (Formerly RK3)

CONTENTS :

Bearings
Shims

* D4 clutches do not have bearings.

Mounting Considerations

In-line Shafts

For direct drive or in-line mounting the shafts should be closely aligned so that the cup will be concentric to the clutch. The cup and clutch should be aligned within .005 inches TIR.

For direct line-to-line shaft mountings, flexible couplings are preferable. One-half of the coupling should be secured to the cup.

Bearings should support the cup on the clutch shaft to maintain concentricity between the clutch and its cup.

A typical flexible coupling in-line shaft direct-drive-mounting is shown.

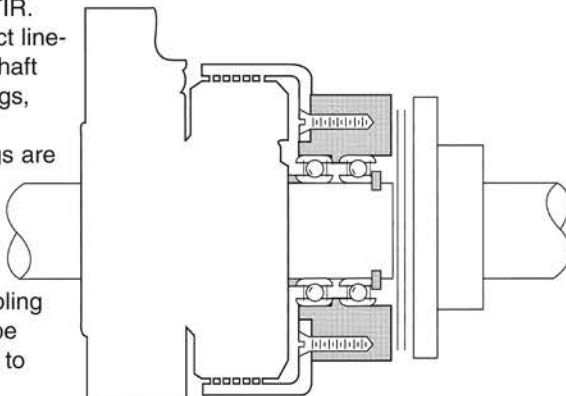

Parallel Shafts

In parallel shaft applications, the cup is secured to a pulley, sprocket or gear. This cup/gear assembly must be bearing mounted on the clutch shaft.

Drive cups, as an optional accessory, are available for all clutch types and sizes as shown on page G3—10.

Cups are furnished with a rough bore as standard and can be modified as required by the application. A typical parallel shaft mounting arrangement is shown.

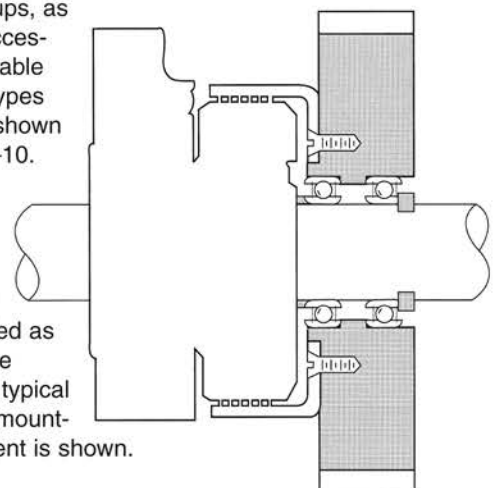

DISC-O-TORQUE® Applications

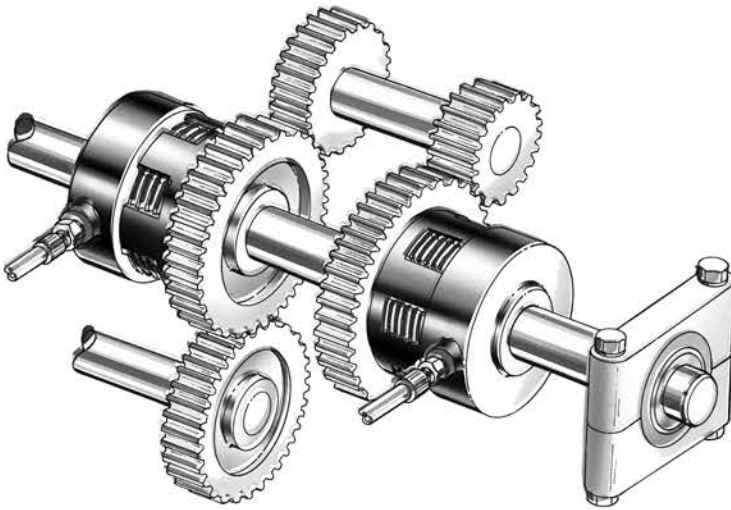

By switching between the two clutches the speed of the driven shaft will change. This allows for different gear ratios and machine speeds.

In this clutch brake application one hydraulic clutch is used to engage the spindle or chuck and upon disengagement the other is used to brake the load.

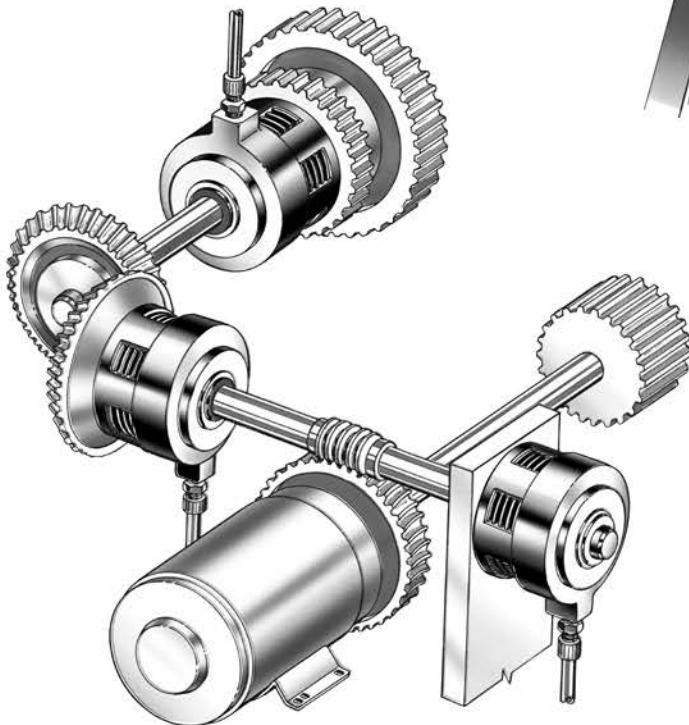
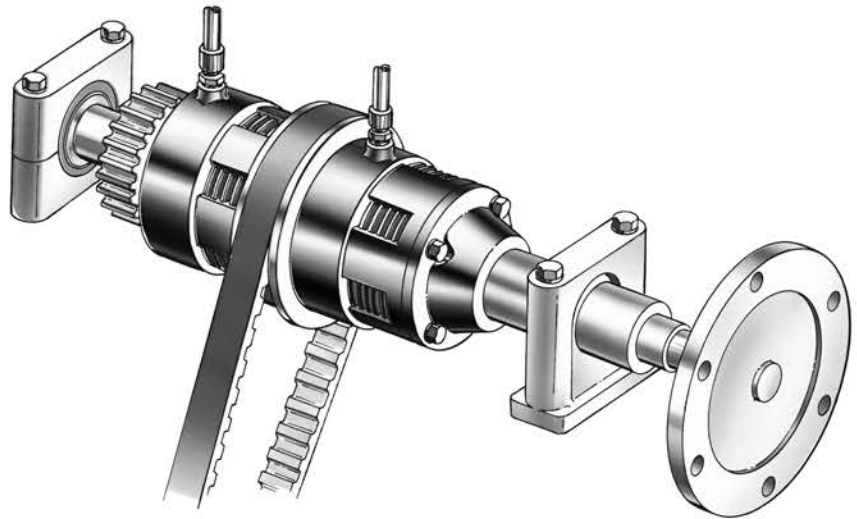

Hydraulic clutches are used in machine tool applications for indexing and speed changes.

The power of one, the strength of many.

Other product solutions from **Altra Industrial Motion**

Our comprehensive product offering is comprised of nine major categories including electromagnetic clutches and brakes, heavy duty clutches and brakes, overrunning clutches, gearing, engineered couplings, engineered bearing assemblies, linear products and belted drives. With thousands of product solutions available, Altra provides true single source convenience while meeting specific customer requirements. Many major OEM's and end users prefer Altra products as their No.1 choice for performance and reliability.

www.altramotion.com



Electromagnetic Clutches and Brakes

Warner Electric
Inertia Dynamics
Matrix International



Heavy Duty Clutches and Brakes

Wichita Clutch
Twiflex Limited
Industrial Clutch



Overrunning Clutches

Formsprag Clutch
Marland Clutch
Stieber Clutch



Engineered Couplings and Universal Joints

TB Wood's
Ameridrives Couplings
Ameridrives Power Transmission
Bibby Turboflex
Lamiflex Couplings



Belted Drives and Sheaves

TB Wood's



Gearing

Boston Gear
Nuttall Gear
Delroyd Worm Gear
Bauer Gear Motor



Linear Products

Warner Linear



Engineered Bearing Assemblies

Kilian Manufacturing



Precision Couplings and Air Motors

Huco Dynatork

All Customer Service phone numbers shown in bold

Electromagnetic Clutches and Brakes

Warner Electric

Electromagnetic Clutches and Brakes

New Hartford, CT - USA
1-800-825-6544

For application assistance:
1-800-825-9050

St Barthelemy d'Anjou, France
+33 (0) 2 41 21 24 24

Precision Electric Coils and Electromagnetic Clutches and Brakes

Columbia City, IN - USA
1-260-244-6183

Matrix International

Electromagnetic Clutches and Brakes, Pressure Operated Clutches and Brakes

Brechin, Scotland
+44 (0) 1356 602000

New Hartford, CT - USA
1-800-825-6544

Inertia Dynamics

Spring Set Brakes, Power On and Wrap Spring Clutch/Brakes

New Hartford, CT - USA
1-800-800-6445

Linear Products

Warner Linear

Linear Actuators
Belvidere, IL - USA
1-800-825-6544

For application assistance:
1-800-825-9050

St Barthelemy d'Anjou, France
+33 (0) 2 41 21 24 24

Couplings

Ameridrives Couplings

Mill Spindles, Ameriflex, Amerisc

Erie, PA - USA
1-814-480-5000

Gear Couplings

San Marcos, TX - USA
1-800-458-0887

Bibby Turboflex

Disc, Gear, Grid Couplings, Overload Clutches

Dewsbury, England
+44 (0) 1924 460801

Boksburg, South Africa
+27 11 918 4270

TB Wood's

Elastomeric Couplings

Chambersburg, PA - USA
1-888-829-6637 – Press #5

For application assistance:
1-888-829-6637 – Press #7

General Purpose Disc Couplings

San Marcos, TX - USA
1-888-449-9439

Ameridrives Power Transmission

Universal Joints, Drive Shafts, Mill Gear Couplings

Green Bay, WI - USA
1-920-593-2444

Huco Dynatork

Precision Couplings and Air Motors

Hertford, England
+44 (0) 1992 501900

Chambersburg, PA - USA
1-888-829-6637

Lamiflex Couplings

Flexible Couplings, Bearing Isolators, and Coupling Guards

São Paulo, SP - Brasil
+55-11-5679-6533

Heavy Duty Clutches and Brakes

Wichita Clutch

Pneumatic Clutches and Brakes

Wichita Falls, TX - USA
1-800-964-3262

Bedford, England
+44 (0) 1234 350311

Twiflex Limited

Caliper Brakes and Thrusters

Twickenham, England
+44 (0) 20 8894 1161

Industrial Clutch

Pneumatic and Oil Immersed Clutches and Brakes

Waukesha, WI - USA
1-262-547-3357

Gearing

Boston Gear

Enclosed and Open Gearing, Electrical and Mechanical P.T. Components

Charlotte, NC - USA
1-800-825-6544

For application assistance:
1-800-816-5608

Bauer Gear Motor

Geared Motors

Esslingen, Germany
+49 (711) 3518 0

Somerset, NJ - USA
1-732-469-8770

Nuttall Gear and Delroyd Worm Gear

Worm Gear and Helical Speed Reducers

Niagara Falls, NY - USA
1-716-298-4100

Overrunning Clutches

Formsprag Clutch

Overrunning Clutches and Holdbacks

Warren, MI - USA
1-800-348-0881 – Press #1

For application assistance:
1-800-348-0881 – Press #2

Marland Clutch

Roller Ramp and Sprag Type Overrunning Clutches and Backstops

South Beloit, IL - USA
1-800-216-3515

Stieber Clutch

Overrunning Clutches and Holdbacks

Heidelberg, Germany
+49 (0) 6221 30 47 0

Belted Drives and Sheaves

TB Wood's

Belted Drives

Chambersburg, PA - USA
1-888-829-6637 – Press #5

For application assistance:
1-888-829-6637 – Press #7

Engineered Bearing Assemblies

Kilian Manufacturing

Engineered Bearing Assemblies

Syracuse, NY - USA
1-315-432-0700

For information concerning our sales offices in Asia Pacific check our website www.altramotion.com.cn



www.tbwoods.com

440 North Fifth Avenue
Chambersburg, PA 17201 - USA
888-829-6637 • 717-264-7161
Fax: 717-264-6427