

# Flexible Couplings

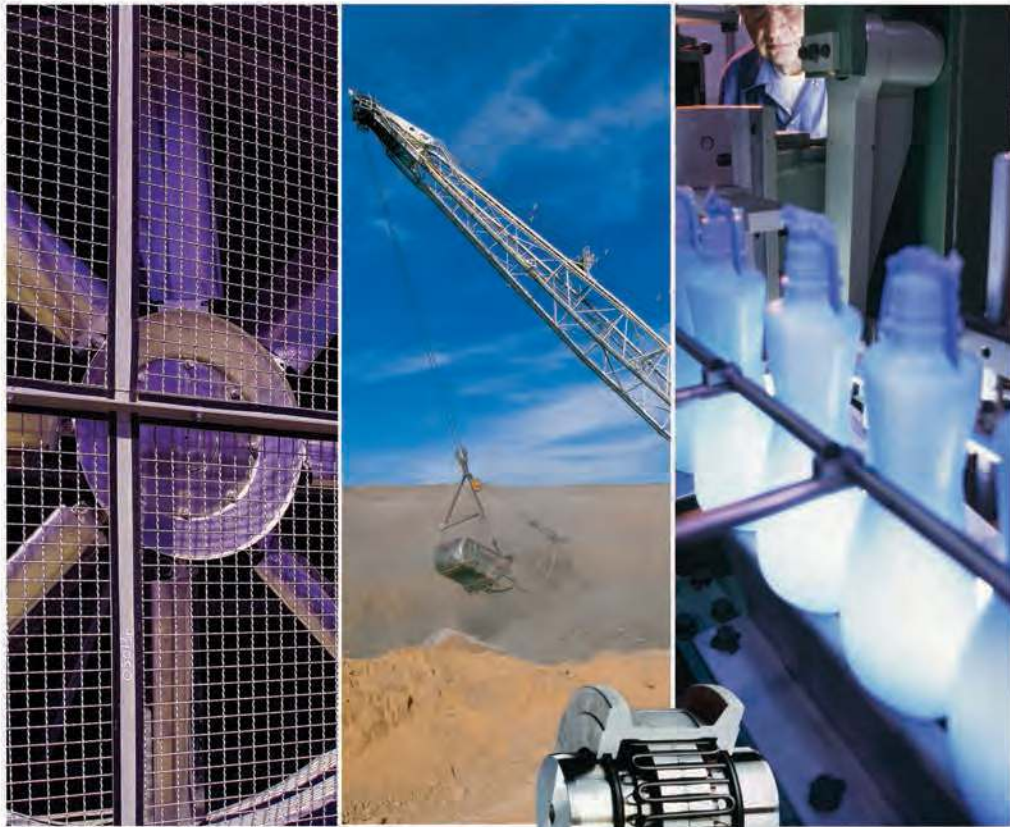

# TB Wood's

TB Wood's is an industry leading designer and manufacturer of mechanical power transmission equipment for industrial control. Our mechanical product lines include: clutch and brake, synchronous and belted variable speed drives; grid, disc, jaw, gear coupling and elastomeric coupling products; sheaves and bushings. Registered trademarks include Sure-Flex®, Dura-Flex®, G-Flex®, and QT Bushings®.

TB Wood's was founded in 1857 and began as a foundry producing wood burning stoves. Our company's tradition of product innovation started early. Wood's entered the power transmission industry at the turn of the century with the introduction of flat belted drives and line shafting.

In April 2007, TB Wood's was purchased by Altra Holdings, Inc. This acquisition placed TB Wood's as part of a larger company with complementary products to help grow the business.



## Altra Industrial Motion

Altra is a leading multinational designer, producer and marketer of a wide range of mechanical power transmission products. We sell our products in over 70 countries throughout the world. Our products are frequently used in critical applications, such as fail-safe brakes for elevators, wheelchairs and forklifts, and in high-volume manufacturing processes, where the reliability and accuracy of our products are critical in both avoiding costly down time and enhancing the overall efficiency of manufacturing operations.

Our products are marketed under a variety of well recognized and established manufacturing brand names. These leading brands are Ameridrives, Boston Gear, Warner Electric, Formsprag Clutch, TB Wood's Incorporated, Industrial Clutch, Kilian Manufacturing, Marland Clutch, Nuttall Gear, Stieber Clutch, Twiflex Ltd, Huco Dynatork, Bibby Turboflex, Matrix International, Inertia Dynamics, Delroyd Worm Gear, Warner Linear, Wichita Clutch, Lamiflex Couplings and Svendborg Brakes.



Visit us on the web at

**tbwoods.com**



# Sure-Flex® Elastomeric Couplings

**F1**



- **Need No Lubrication, No Maintenance**
- **Quick, Easy Installation**
- **Clean, Quiet Performance**

## Capabilities

### 4-WAY FLEXING ACTION absorbs all types of shock, vibration and misalignment

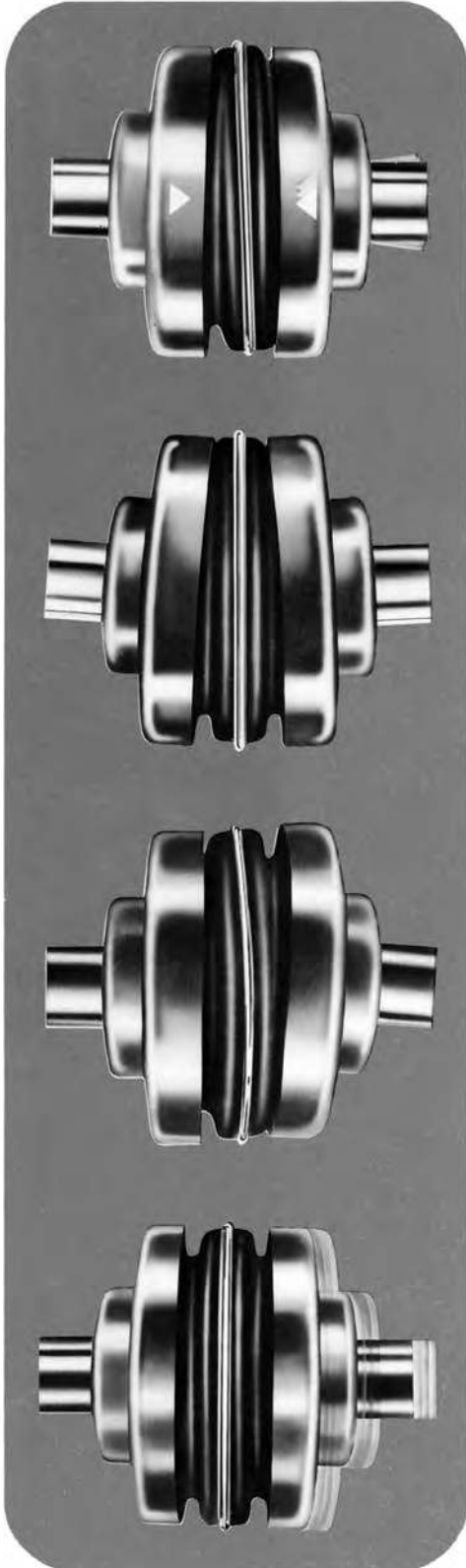

#### TORSIONAL

Sure-Flex coupling sleeves have an exceptional ability to absorb torsional shock and dampen torsional vibrations. The EPDM and Neoprene sleeves wind-up approximately 15° torsionally at their rated torque. Hytrel sleeves will wind-up about 7°.

#### ANGULAR

The unique design of the Sure-Flex coupling's teeth allows for the absorption of angular misalignment without wear. Refer to page F1—18 for actual allowable misalignment limits. These limits allow for the alignment of the coupling using only a scale and calipers.

#### PARALLEL

Parallel misalignment is absorbed without wear or appreciable energy losses. The lateral flexibility of the coupling sleeve minimizes radial bearing loads normally associated with parallel misalignment. This feature also allows for easier installation by the use of components bored for slip fits without fretting corrosion occurring at the shaft. Refer to page F1—18 for parallel misalignment limits. Only a straight-edge and feeler gage are required to obtain these limits.

#### AXIAL

Sure-Flex couplings may be used in applications with limited axial shaft movements. The axial compressibility of the EPDM and Neoprene sleeves allows for shaft end-float without the absolute transfer of thrust loads.

**Features**



**EASY, QUICK  
INSTALLATION**

Sure-Flex can be installed quickly and easily, because there are no bolts, gaskets, covers or seals. Alignment can be checked with a straightedge placed across the outside of the precision-machined flanges. No special tools are needed for installation, alignment or removal.



**NO LUBRICATION,  
TROUBLE-FREE OPERATION**

The teeth of the sleeve lock into the teeth of the flanges without clamps or screws, tightening under torque to provide smooth transmission of power. There is no rubbing action of metal against rubber to cause wear. Couplings are not affected by abrasives, dirt, or moisture. This eliminates the need for lubrication or maintenance, provides clean, dependable, quiet performance.

**SURE-FLEX SELECTION**

**Sure-Flex couplings are selected as component parts.**

1. Determine SLEEVE material and type.  
Refer to pages F1—4 & 5
2. Determine coupling SIZE.  
Refer to pages F1—6, 7, & 8
3. Determine FLANGES to be used.  
Refer to pages F1—9 thru 16

**Specify coupling components.**

- Example #1 - Close coupled  
Size 6, Type S flange w 1-3/8 bore  
Size 6, Type S flange w 1" bore  
Size 6, Solid EPDM sleeve
- Example #2 - 5" Between shaft spacer  
Size 9, Type SC flange for #11 hub  
Size 9, Type SC flange for #9 hub  
Size 11 hub w 2-3/8 bore  
Size 9 short hub w 1-1/8 bore  
Size 9 Solid Hytrel sleeve

PROD. NUMBER	PROD. DESCRIPTION
6S138	6Sx1-3/8
6S1	6Sx1
6J	6JE
9SC5011	9SC50-11
9SC50	9SC50
11SCH238	11SCH x 2-3/8
9SCHS118	9SCHS x 1-1/8
9H	9H

# Sure-Flex® Sleeve

## Selection

Sure-Flex Sleeves are available in four materials or compounds and various shape configurations.

	EPDM	Neoprene	Hytrel	Urethane
<b>CONSTRUCTIONS AVAILABLE</b>				
1 pc, unsplit	JE	JN	H	U
1 pc, split	JES	JNS	-	-
2 piece	E	N	HS	-
<b>TYPICAL USE</b>	General Purpose	Oil Resist Non-flame	General Purpose	Stiffness
<b>REL. RATING</b>	1X	1X	4X	4X
<b>WIND-UP ANGULAR MISALIGN</b>	15°	15°	7°	3°
	1°	1°	1/4°	1/4°
<b>TEMPERATURE (F)</b>				
maximum	+275°	+200°	+250°	+200°
minimum	-30°	-0°	-65°	-80°

## SURE-FLEX SLEEVES







Product No.	Product Description
3J	3JE EPDM
4J	4JE EPDM
5J	5JE EPDM
6J	6JE EPDM
7J	7JE EPDM
8J	8JE EPDM
9J	9JE EPDM
10J	10JE EPDM
3JS	3JES EPDM Split
4JS	4JES EPDM Split
5JS	5JES EPDM Split
6JS	6JES EPDM Split
7JS	7JES EPDM Split
8JS	8JES EPDM Split
9JS	9JES EPDM Split
10JS	10JES EPDM Split
3JN	3JN Neoprene
4JN	4JN Neoprene
5JN	5JN Neoprene
6JN	6JN Neoprene
7JN	7JN Neoprene
8JN	8JN Neoprene
3JNS	3JNS Neoprene Split
4JNS	4JNS Neoprene Split
5JNS	5JNS Neoprene Split
6JNS	6JNS Neoprene Split
7JNS	7JNS Neoprene Split
8JNS	8JNS Neoprene Split

Product No.	Product Description
4	4E EPDM
5	5E EPDM
6	6E EPDM
7	7E EPDM
8	8E EPDM
9	9E EPDM
10	10E EPDM
11	11E EPDM
12	12E EPDM
13	13E EPDM
14	14E EPDM
16	16E EPDM
4N	4N Neoprene
5N	5N Neoprene
6N	6N Neoprene
7N	7N Neoprene
8N	8N Neoprene
9N	9N Neoprene
10N	10N Neoprene
11N	11N Neoprene
12N	12N Neoprene
13N	13N Neoprene
14N	14N Neoprene

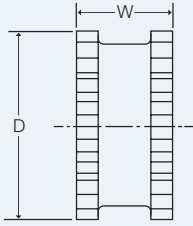
Product No.	Product Description
6H	6H Hytrel
7H	7H Hytrel
8H	8H Hytrel
9H	9H Hytrel
10H	10H Hytrel
11H	11H Hytrel
12H	12H Hytrel
6HS	6HS Split Hytrel
7HS	7HS Split Hytrel
8HS	8HS Split Hytrel
9HS	9HS Split Hytrel
10HS	10HS Split Hytrel
11HS	11HS Split Hytrel
12HS	12HS Split Hytrel
13HS	13HS Split Hytrel
14HS	14HS Split Hytrel
10U	10U Urethane
11U	11U Urethane
12U	12U Urethane

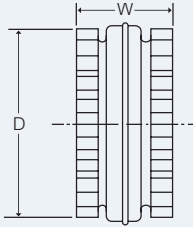
## Selection

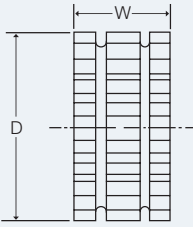
Flexible sleeves for Wood's Sure-Flex couplings are available in four materials (EPDM Neoprene, Hytrel and Urethane) and in three basic constructions. Characteristics of the materials are given on page F1—4 and the various types are shown and described here.

 <p><b>JE, JN</b></p>		 <p><b>Types JES, JNS</b></p>	<p><b>JE-JES-JN-JNS</b></p> <p>J sleeves are molded EPDM rubber (E) or Neoprene (N). They are available in one-piece solid construction (JE, JN) or one-piece split construction (JES, JNS). These sleeves may be used in any Sure-Flex flange within a given size.</p>
 <p><b>E and N (Assembled)</b></p>		 <p><b>Types E and N (Disassembled)</b></p>	<p><b>E-N</b></p> <p>These sleeves are of two-piece design with a retaining ring. They are available in either EPDM (E) or Neoprene (N). They may be used with any flange within a given size. Sleeves are shown here assembled and disassembled.</p>
 <p><b>H or U</b></p>		 <p><b>HS</b></p>	<p><b>H-HS-U</b></p> <p>H (Hytrel) and U (Urethane) sleeves, designed for high-torque applications, transmit four times as much power as an equivalent EPDM or Neoprene sleeve. Available in one-piece solid construction (H or U) or two-piece split construction (HS), these can be used only with S, C and SC flanges. They cannot be used with J or B flanges or as direct replacements for EPDM or Neoprene sleeves.</p>

### DIMENSIONS (in.)

Coupling Size	JE, JES, JN & JNS Sleeves EPDM & Neoprene			E and N Sleeves EPDM & Neoprene			H, U & HS Sleeves Hytrel & Urethane		
	D	W	Wt. (lbs.)	D	W	Wt. (lbs.)	D	W	Wt. (lbs.)
3	1-7/8	1	.06	-	-	-	-	-	-
4	2-5/16	1-1/4	.10	2-5/16	1-1/4	.11	-	-	-
5	2-15/16	1-9/16	.20	2-15/16	1-9/16	.25	-	-	-
6	3-3/4	1-7/8	.40	3-3/4	1-7/8	.49	3-3/4	1-7/8	.44
7	4-11/32	2-3/16	.62	4-11/32	2-3/16	.77	4-11/32	2-3/16	.69
8	5-1/16	2-1/2	1.13	5-1/16	2-1/2	1.4	5-1/16	2-1/2	1.4
9*	6	3	1.46	6	3	2.0	6	3	1.8
10*	7-1/16	3-7/16	2.32	7-1/16	3-7/16	3.2	7-1/16	3-7/16	2.9
11	-	-	-	8-3/16	4	5.1	8-3/16	4	4.5
12	-	-	-	9-9/16	4-11/16	8.1	9-9/16	4-11/16	7.3
13	-	-	-	11-3/16	5-1/2	13.0	11-3/16	5-1/2	11.8
14	-	-	-	13-3/32	6-1/2	21.1	13-3/32	6-1/2	19.3
16	-	-	-	17-29/32	8-3/4	45.3	-	-	-

The 13 and 14 Hytrel available with HS sleeves only.

\*All 9J and 10J sleeves available in EPDM only.   Only sizes available in Urethane.

## Selection

### 1. Select Load Symbol based on your driven machine.

Application	Load Symbol	Application	Load Symbol	Application	Load Symbol
AGITATORS—Paddle, Propeller, Screw . . . . .	L	DEWATERING SCREEN (sewage) . . . . .	M	MILLS	
BAND RESAW (lumber) . . . . .	M	DISC FEEDER . . . . .	L	Ball, Pebble, Rod, Tube, Rubber Tumbling . . .H	
BARGE HAUL PULLER . . . . .	H	DOUGH MIXER . . . . .	M	Dryer and Cooler . . . . .	M
BARKING (lumber) . . . . .	H	DRAW BENCH CONVEYOR and MAIN DRIVE . . . . .	H	MIXERS	
BAR SCREEN (sewage) . . . . .	L	DREDGES		Concrete, Muller . . . . .	M
BATCHES (textile) . . . . .	L	Cable Reel, Pumps . . . . .	M	Banbury . . . . .	H
BEATER AND PULPER (paper) . . . . .	M	Cutter Head Drive, Jig Drive, Screen Drive .H		ORE CRUSHER . . . . .	H
BENDING ROLL (metal) . . . . .	M	Maneuvering and Utility Winch, Stackers . . .M		OVEN CONVEYOR . . . . .	L
BLEACHER (paper) . . . . .	L	DYNAMOMETER . . . . .	L	PLANER (metal or wood) . . . . .	M
BLOWERS		DRYERS (rotary) . . . . .	M	PRESSES	
Centrifugal, Vane . . . . .	L	EDGER (lumber) . . . . .	H	Brick, Briquette Machine . . . . .	H
Lobe . . . . .	M	ELEVATOR		Notching, Paper, Punch, Printing . . . . .	M
BOTTLING MACHINERY . . . . .	L	Bucket . . . . .	M	PUG MILL . . . . .	M
BREW KETTLES (distilling) . . . . .	L	Escalator . . . . .	L	PULP GRINDER (paper) . . . . .	H
BUCKET ELEVATOR OR CONVEYOR . . . . .	M	Freight, Passenger, Service, Man Lift . . . . .	H	PULVERIZERS	
CALENDERS		ESCALATORS . . . . .	L	Hammermill—light duty, Roller . . . . .	M
Calendar (paper) . . . . .	M	EXTRUDER (metal) . . . . .	H	Hammermill—heavy duty, Hog . . . . .	H
Calendar-super (paper), Calendar (rubber) .H		FANS		PUMPS	
CANE KNIVES (sugar) . . . . .	M	Centrifugal . . . . .	L	Centrifugal, Axial . . . . .	L
CARD MACHINE (textile) . . . . .	H	Cooling Tower . . . . .	L	Gear, Lobe, Vane . . . . .	M
CAR DUMPERS . . . . .	H	Forced Draft, Large Industrial or Mine . . . . .	M	Reciprocating—sgl. or dbl. acting, cylinder . . . . .	*
CAR PULLERS . . . . .	M	FEEDERS		REEL, REWINDER (paper) CABLE . . . . .	M
CEMENT KILN . . . . .	H	Apron, Belt, Disc . . . . .	L	ROD MILL . . . . .	H
CENTRIFUGAL BLOWERS,		Reciprocating . . . . .	H	SAWDUST CONVEYOR . . . . .	L
COMPRESSORS, FANS or PUMPS . . . . .	L	Screw . . . . .	M	SCREENS	
CHEMICAL FEEDERS (sewage) . . . . .	L	FILTER, PRESS-OIL . . . . .	M	Air Washing, Water . . . . .	L
CHILLER (oil) . . . . .	M	GENERATORS		Rotary for coal or sand . . . . .	M
CHIPPER (paper) . . . . .	H	Uniform load . . . . .	L	Vibrating . . . . .	H
CIRCULAR RESAW (lumber) . . . . .	M	Varying load, Hoist . . . . .	M	SCREW CONVEYOR . . . . .	L
CLARIFIER or CLASSIFIER . . . . .	L	Welders . . . . .	H	SLAB CONVEYOR (lumber) . . . . .	M
CLAY WORKING MACHINERY . . . . .	M	GRIT COLLECTOR (sewage) . . . . .	L	SLITTERS (metal) . . . . .	M
COLLECTORS (sewage) . . . . .	L	GRIZZLY . . . . .	H	SOAPERS (textile) . . . . .	L
COMPRESSORS		HAMMERMILL		SORTING TABLE (lumber) . . . . .	M
Centrifugal . . . . .	L	Light Duty, Intermittent . . . . .	M	SPINNER (textile) . . . . .	M
Reciprocating . . . . .	*	Heavy Duty, Continuous . . . . .	H	STOKER . . . . .	L
Screw, Lobe . . . . .	L	HOISTS		SUCTION ROLL (paper) . . . . .	M
CONCRETE MIXERS . . . . .	M	Heavy Duty . . . . .	H	TENTER FRAMES (textile) . . . . .	M
CONVERTING MACHINE (paper) . . . . .	M	Medium Duty . . . . .	M	TIRE BUILDING MACHINES . . . . .	H
CONVEYORS		JORDAN (paper) . . . . .	H	TIRE & TUBE PRESS OPENER . . . . .	L
Apron, Assembly Belt, Flight, Oven, Screw .L		KILN, ROTARY . . . . .	H	TUMBLING BARRELS . . . . .	H
Bucket . . . . .	M	LAUNDRY WASHER or TUMBLER . . . . .	H	WASHER and THICKENER (paper) . . . . .	M
COOKERS—Brewing, Distilling, Food . . . . .	L	LINE SHAFTS . . . . .	L	WINCHES . . . . .	M
COOLING TOWER FANS . . . . .	H	LOG HAUL (lumber) . . . . .	H	WINDERS, Paper, Textile, Wire . . . . .	M
COUCH (paper) . . . . .	M	LOOM (textile) . . . . .	M	WINDLASS . . . . .	M
CRANES and HOISTS . . . . .	M	MACHINE TOOLS, MAIN DRIVE . . . . .	M	WIRE	
Heavy Duty Mine . . . . .	H	MANGLE (textile) . . . . .	L	Drawing . . . . .	H
CRUSHERS—Cane (sugar), Stone or Ore . . .H		MASH TUBS (distilling) . . . . .	L	Winding . . . . .	M
CUTTER—Paper . . . . .	H	MEAT GRINDER . . . . .	M	WOODWORKING MACHINERY . . . . .	L
CYLINDER (paper) . . . . .	H	METAL FORMING MACHINES . . . . .	M		

\*Consult Factory

### 2. Determine Service Factor using Load Symbol and driveR.

Load Symbol	L Light	M Medium	H Heavy
Standard AC Motor			
DC Shunt Motor	1.25	1.5	2.0
*Engine, 8 or more cylinders			
High Torque AC Motor			
DC Series & Comp.	1.5	2.0	2.5
*Engine, 4-6 cylinders			
*Engine, 3 cylinders or less	2.0	2.5	3.0
Turbine	1.0	1.25	1.5

\*On applications involving varying torque loads, design around the maximum load. Then determine the resulting service factor at minimum load. If this value is greater than 4.0, special coupling alignment will be required (see page F1—18).

**Caution:** Applications involving reciprocating engines and reciprocating driven devices are subject to rotational vibrational critical speeds which may destroy the coupling. The factory can determine these speeds when the rotational inertia ( $WR^2$ ) of the driveR and driveN units is known.



3. If coupling to the shaft of a 60 HZ AC motor, you may refer to page 8, locate the correct chart & columns for your sleeve material, motor speed and service factor; you can read the coupling size across from the motor horsepower.  
 Example: For 150 HP @ 1750 RPM and 1.5 Service Factor - Use #13 EPDM or Neoprene or #10 Hytrel or Urethane.
4. For other speeds, use the following formula to calculate the required coupling horsepower rating @ 100 rpm.  

$$\text{HP @ 100 rpm} = \text{HP} \times \text{Service Factor} \times 100 / \text{coupling RPM}$$
5. Use the chart below to find a coupling with a HP @ 100 RPM rating which is greater than calculated above.  
 Example: For 5 HP @ 55 RPM and 1.25 Service Factor:  

$$\text{HP @ 100} = 5 \times 1.25 \times 100 / 55 = 11.36$$
  
 Use #12 EPDM or Neoprene or #9 Hytrel with rating of 11.4 HP.

### COUPLING RATINGS

Size	EPDM Sleeves	Neoprene Sleeves	HP @ RPM				Torque (in. lbs.)	Stiffness (in. lbs./rad)	Max RPM
			100	1160	1750	3500			
3	JE,JES	JN,JNS	0.1	1.1	1.7	3.3	60	229	9200
4	E,JE,JES	N,JN,JNS	0.2	2.2	3.3	6.7	120	458	7600
5	E,JE,JES	N,JN,JNS	0.4	4.4	6.7	13	240	916	7600
6	E,JE,JES	N,JN,JNS	0.7	8.3	12.5	25	450	1718	6000
7	E,JE,JES	N,JN,JNS	1.2	13	20	40	725	2769	5250
8	E,JE,JES	N,JN,JNS	1.8	20	32	63	1135	4335	4500
9	E,JE,JES	N	2.9	33	50	100	1800	6875	3750
10	E,JE,JES	N	4.6	53	80	160	2875	10980	3600
11	E	N	7.2	83	126	252	4530	17300	3600
12	E	N	11.4	132	200		7200	27500	2800
13	E	N	18.0	209	315		11350	43350	2400
14	E	N	28.6	331	500		18000	68755	2200
16	E		75.0	870			47250	180480	1500

Size	Hytrel Sleeves	Urethane Sleeves	HP @ RPM				Torque (in. lbs.)	Stiffness (in. lbs./rad)	Max RPM
			100	1160	1750	3500			
6	H, HS		2.9	33	50	100	1800	10000	6000
7	H, HS		4.6	53	80	160	2875	20000	5250
8	H, HS		7.2	84	126	252	4530	30000	4500
9	H, HS		11.4	132	200	400	7200	47500	3750
10	H, HS	U	18.0	209	315	630	11350	100000*	3600
11	H, HS	U	28.6	331	500	1000	18000	125000*	3600
12	H, HS	U	50.0	580	875		31500	225000*	2800
13	HS		75.0	870	1312		47268	368900	2400
14	HS		115.0	1334	2013		72480	593250	2200

\* Urethane values are 220000, 350000, and 600000.

## Selection

### EPDM or NEOPRENE SLEEVES

860 RPM MOTORS						1160 RPM MOTORS						1750 RPM MOTORS						3500 RPM MOTORS					
HP	Service Factors					HP	Service Factors					HP	Service Factors					HP	Service Factors				
	1.0	1.25	1.5	2.0	2.5		1.0	1.25	1.5	2.0	2.5		1.0	1.25	1.5	2.0	2.5		1.0	1.25	1.5	2.0	2.5
1/2	3	3	3	4	4	1/2	3	3	3	3	4	1/2	3	3	3	3	3	1/2	3	3	3	3	3
3/4	3	4	4	4	5	3/4	3	3	4	4	4	3/4	3	3	3	3	4	3/4	3	3	3	3	3
1	4	4	4	5	5	1	3	4	4	4	5	1	3	3	3	4	4	1	3	3	3	3	3
1-1/2	4	5	5	5	6	1-1/2	4	4	5	5	5	1-1/2	3	4	4	4	5	1-1/2	3	3	3	3	4
2	5	5	5	6	6	2	4	5	5	5	6	2	4	4	4	5	5	2	3	3	3	4	4
3	5	6	6	6	7	3	5	5	6	6	6	3	4	5	5	5	6	3	3	4	4	4	5
5	6	6	7	7	8	5	6	6	6	7	7	5	5	5	6	6	6	5	4	4	5	5	5
7-1/2	7	7	8	8	9	7-1/2	6	7	7	8	8	7-1/2	6	6	6	7	7	7-1/2	5	5	5	6	6
10	7	8	8	9	9	10	7	7	8	8	9	10	6	6	7	7	8	10	5	5	6	6	6
15	8	9	9	10	10	15	8	8	9	9	10	15	7	7	8	8	9	15	6	6	6	7	7
20	9	9	10	10	11	20	8	9	9	10	10	20	7	8	8	9	9	20	6	6	7	7	8
25	9	10	10	11	11	25	9	9	10	10	11	25	8	8	9	9	10	25	6	7	7	8	8
30	10	10	11	11	12	30	9	10	10	11	11	30	8	9	9	10	10	30	7	7	8	8	9
40	10	11	11	12	12	40	10	10	11	11	12	40	9	9	10	10	11	40	7	8	8	9	9
50	11	11	12	12	13	50	10	11	11	12	12	50	9	10	10	11	11	50	8	8	9	9	10
60	11	12	12	13	13	60	11	11	12	12	13	60	10	10	11	11	12	60	8	9	9	10	10
75	12	12	13	13	14	75	11	12	12	13	13	75	10	11	11	12	12	75	9	9	10	10	11
100	12	13	13	14	14	100	12	12	13	13	14	100	11	11	12	12	13	100	9	10	10	11	11
125	13	13	14	14	15	125	12	13	13	14	14	125	11	12	12	13	13	125	10	10	11	11	
150	13	14	14	16	16	150	13	13	14	14	16	150	12	12	13	13	14	150	10	11	11		
200	14	14	16	16	16	200	13	14	14	16	16	200	12	13	13	14	14	200	11	11			
250	14	16	16	16	16	250	14	14	16	16	16	250	13	13	14	14		250	11				
300	16	16	16	16		300	14	16	16	16	16	300	13	14	14			300					
350	16	16	16			350	16	16	16	16	16	350	14	14				350					
400	16	16	16			400	16	16	16	16		400	14	14				400					
450	16	16				450	16	16				450	14					450					
500	16	16				500	16	16				500	14					500					
600	16					600	16					600						600					
700						700						700						700					
800						800						800						800					

### HYTREL or URETHANE SLEEVES

860 RPM MOTORS						1160 RPM MOTORS						1750 RPM MOTORS						3500 RPM MOTORS					
HP	Service Factors					HP	Service Factors					HP	Service Factors					HP	Service Factors				
	1.0	1.25	1.5	2.0	2.5		1.0	1.25	1.5	2.0	2.5		1.0	1.25	1.5	2.0	2.5		1.0	1.25	1.5	2.0	2.5
7-1/2	6	6	6	6	6	7-1/2	-	-	-	-	-	7-1/2	-	-	-	-	-	7-1/2	-	-	-	-	-
10	6	6	6	6	6	10	6	6	6	6	6	10	-	-	-	-	-	10	-	-	-	-	-
15	6	6	6	7	7	15	6	6	6	6	7	15	6	6	6	6	6	15	-	-	-	-	-
20	6	6	7	7	8	20	6	6	6	7	7	20	6	6	6	6	6	20	-	-	-	-	-
25	6	7	7	8	8	25	6	6	7	7	8	25	6	6	6	6	7	25	-	-	-	-	-
30	7	7	8	8	9	30	6	7	7	8	8	30	6	6	6	7	7	30	6	6	6	6	6
40	7	8	8	9	9	40	7	7	8	8	9	40	6	6	7	7	8	40	6	6	6	6	6
50	8	8	9	9	10	50	7	8	8	9	9	50	6	7	7	8	8	50	6	6	6	6	7
60	8	9	9	10	10	60	8	8	9	9	10	60	7	7	8	8	9	60	6	6	6	7	7
75	9	9	10	10	11	75	8	9	9	10	10	75	7	8	8	9	9	75	6	6	7	7	8
100	9	10	10	11	11	100	9	9	10	10	11	100	8	8	9	9	10	100	6	7	7	8	8
125	10	10	11	11	12	125	9	10	10	11	11	125	8	9	9	10	10	125	7	7	8	8	9
150	10	11	11	12	12	150	10	10	11	11	12	150	9	9	10	10	11	150	7	8	8	9	9
200	11	11	12	12	13	200	10	11	11	12	12	200	9	10	10	11	11	200	8	8	9	9	10
250	11	12	12	13	13	250	11	11	12	12	13	250	10	10	11	11	12	250	8	9	9	10	10
300	12	12	13	13	14	300	11	12	12	13	13	300	10	11	11	12	12	300	9	9	10	10	11
350	12	12	13	14	14	350	12	12	12	13	14	350	11	11	12	12	12	350	9	10	10	11	11
400	12	13	13	14	14	400	12	12	13	13	14	400	11	11	12	12	13	400	9	10	10	11	11
500	13	13	14	14	-	500	12	13	13	14	14	500	11	12	12	13	13	500	10	10	11	11	-
600	13	14	14	-	-	600	13	13	13	14	-	600	12	12	13	13	14	600	10	11	11	-	-
700	14	14	-	-	-	700	13	13	14	14	-	700	12	12	13	14	14	700	11	11	-	-	-
800	14	14	-	-	-	800	13	14	14	-	-	800	12	13	13	14	14	800	11	11	-	-	-
900	14	-	-	-	-	900	14	14	14	-	-	900	13	13	14	14	-	900	11	-	-	-	-
1000	-	-	-	-	-	1000	14	14	-	-	-	1000	13	13	14	14	-	1000	11	-	-	-	-

# Type J Sure-Flex® BTS

## For Close Coupled Applications

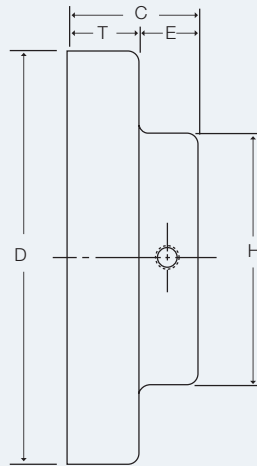

### FLANGES

Type J flanges sizes 3, 4 and 5 are manufactured of sintered carbon steel. The powdered metal manufacturing process provides high dimensional accuracy and uniform material properties for high strength. Size 6 is made of high strength cast iron. All flanges are bored-to-size for a slip fit on standard shafts. The outside diameter of the flange is machined so the surface can be used to check alignment without a special tool. Type J flanges can be used with sleeves of any construction except the Hytrel. Each flange has a keyseat and one (1) setscrew over the keyway. All have a setscrew at 90° from the keyway.

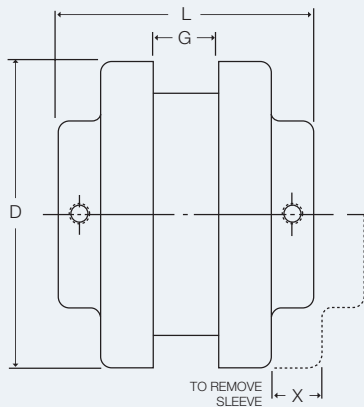

### COUPLINGS

Type J Sure-Flex Couplings are bored-to-size. Normally, they employ the one-piece JE sleeve, or the one-piece JES sleeve with saw cut to permit replacement where there is insufficient gap between shafts.

Spacing between internal flange hubs equals G. Spacing between shafts should be greater than 1/8 in. and less than L minus .85 times the sum of the two bore diameters.

To order complete couplings, specify coupling size with flange symbol (J) giving bore and keyseat. Refer to page F1-3 to order the required coupling.

## DIMENSIONS (in.)

Product No.	Dimensions									Wt. (lbs.)	STOCK BORES*																							
	C	D	E	G	H	L	T	X	(Inches)											Max Bore	Millimeters													
									3/8		1/2	5/8	3/4	7/8	15/16	1	1-1/8	1-3/16	1-1/4		1-3/8	9	11	12	14	15	16	19	20	24	25			
3J	51/64	2.062	13/32	3/8	1-1/2	1-31/32	25/64	5/8	0.3	X	X	X	X	X									7/8	-	X	X	X	X	X	X	-	-	-	
4J	55/64	2.500	27/64	43/64	1-5/8	2-25/64	7/16	5/8	0.4		X	X	X	X	X	X							1	-	-	-	X	X	X	X	X	X	X	X
5J	1-3/64	3.250	29/64	3/4	1-7/8	2-27/32	19/32	59/64	0.9		X	X	X	X	X	X	X						1-1/8	-	-	-	-	-	-	-	-	-	-	-
6J	1-5/16	4.000	9/16	7/8	2-1/2	3-1/2	3/4	1-3/32	1.2				X	X	X	X	X	X	X	X	X		1-3/8	-	-	-	-	-	-	-	-	-	-	-

\*We do not recommend reboring the 3J and 4J Flanges. See page F1-13 for standard keyseat dimensions & F1-10 for bore tolerances.

■ Approximate weight for each flange.





# Type S Sure-Flex® BTS

## For Close Coupled Applications

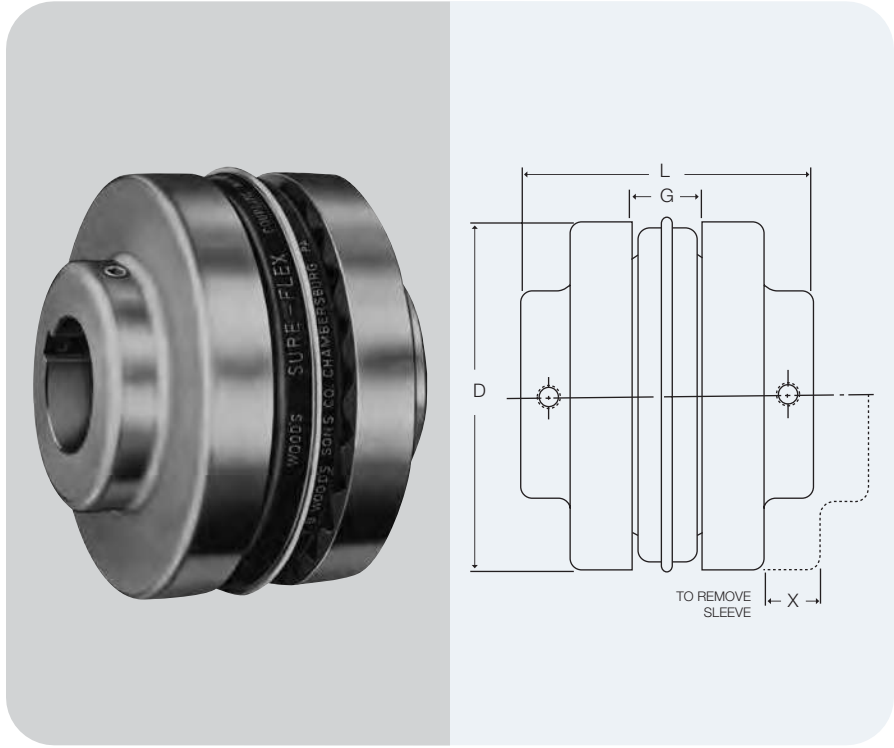

### COUPLINGS

Type S Sure-Flex couplings are normally supplied with the two-piece E sleeve. However, any of the sleeves shown on page F1—5 can be used with Type S flanges.

Spacing between internal flange hubs equals L minus 2 times C. Spacing between shafts should be greater than 1/8 in. and less than L minus .85 times the sum of the two bore diameters.

To order complete couplings, specify coupling size with flange symbol (S) giving bore and keyseat. Refer to page F1—3 to order the required coupling.

### DIMENSIONS (in.)

STOCK BORES																		Max. Bore		SHALLOW KEYSEAT DIMENSIONS ②																		
Millimeters																		① Standard Keyseat	② Shallow Keyseat	Bore	K.S.	Key	Bore	K.S.	Key	Bore	K.S.	Key										
14	15	16	19	20	24	25	28	30	32	35	38	42	45	48	50	52	55												60	65	70	80	90					
X	X	X	X	X	X	X	X																	1-3/16	1-1/4	1-1/4	1/4 X 1/16	1/4 X 3/16 X 1-3/8	-	-	-	-	-	-	-			
	X		X	X	X	X	X	X	X	X														1-7/16	1-1/2	-	-	-	-	-	-	-	-	-	-			
																								-	1-3/4	1-1/2 & 1-5/8	3/8 X 1/8	3/8 X 5/16 X ▲	1-3/4	3/8 X 1/16	3/8 X 1/4 X 1-1/4	-	-	-	-	1-7/8	1/2 X 1/16	1/2 X 5/16 X 1-9/16
																								-	1-7/8	-	-	-	-	-	-	-	-	-	-			
			X	X	X	X	X	X	X	X	X													1-5/8	1-7/8	1-7/8	1/2 X 1/8	1/2 X 3/8 X 1-7/8	-	-	-	-	-	-	-			
				X	X	X	X	X	X	X		X	X	X	X									1-15/16	2-1/4	2-1/8	1/2 X 3/16	1/2 X 7/16 X 2-1/8	-	-	-	-	-	-	-			
																								-	2-3/8	-	-	-	2-3/8	5/8 X 1/8	5/8 X 7/16 X 1-7/8	-	-	-	-			
				X																				2-1/2	2-3/4	-	-	-	-	-	-	-	-	-	-			
																								-	2-7/8	2-7/8	3/4 X 1/8	3/4 X 1/2 X 2-1/4	-	-	-	-	-	-	-	-		
							X	X	X	X	X	X	X	X	X	X	X	X						2-3/4	3-1/8	2-7/8	3/4 X 1/4	3/4 X 5/8 X 2-3/4	-	-	-	-	-	-	-	-		
																								-	3-3/8	-	-	-	3-3/8	7/8 X 3/16	7/8 X 5/8 X 2-5/8	-	-	-	-			
								X	X	X	X	X	X	X	X	X	X	X						3-3/8	3-7/16	3-7/16	7/8 X 3/16	7/8 X 5/8 X 3-7/16	-	-	-	-	-	-	-	-		
																								-	3-7/8	3-7/8	1 X 1/4	1 X 3/4 X 3	-	-	-	-	-	-	-	-		
									X			X	X	X	X	X	X							3-7/8	3-15/16	-	-	-	-	-	-	-	-	-	-			
																								4-1/2	-	-	-	-	-	-	-	-	-	-	-			
																								5	-	-	-	-	-	-	-	-	-	-	-			
																								5-1/2	6	-	-	-	-	-	-	-	-	-	-			

① See charts on page F1—13

② Some large bore Type S flanges are supplied with shallow keyseats. In these cases, a rectangular key is furnished. The bores involved are listed above.

▲ 1-5/8 for 1-1/2 bore, 1-5/16 for 1-5/8 bore.

# Type B Bushed - Flex QD

## For Close Coupled Applications

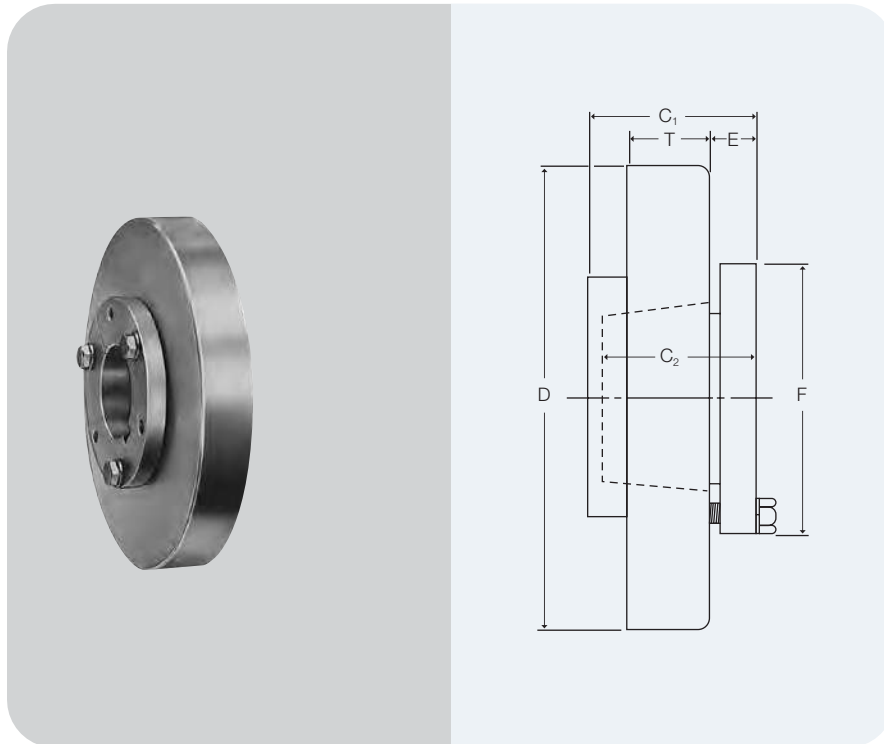

### FLANGES

Type B flanges are made of high-strength cast iron the same as Types S, C and SC Sure-Flex flanges. Type B, however, is designed to accommodate Wood's Sure-Grip Bushing for easy installation and removal.

### BUSHINGS

Sure-Grip Bushings offer convenient mounting of the flange to the shaft securely without setscrews. They are tapered and are split through both the bushing flange and taper to provide a clamp fit, eliminating wobble, vibration and fretting corrosion. This is the same bushing used in Wood's sheaves and pulleys and is readily available everywhere.

### Dimensions (in.)

Product No.	Bushing Required	Dimensions									Max. * Bore	Flange	Weight (lbs.) ■ Bushing
		C <sub>1</sub>	C <sub>2</sub>	D	E	F	G	L	T	X			
<b>6B</b>	JA	1-7/32	1	4.000	15/32	2	7/8	3-3/8	25/32	1-3/32	1-1/4	1.4	.8
<b>7B</b>	JA	1-5/8	1	4.625	15/32	2	1	3-1/2	25/32	1-5/16	1-1/4	1.9	.8
<b>8B</b>	SH	1-29/32	1-1/4	5.450	9/16	2-11/16	1-1/8	4-1/16	29/32	1-1/2	1-5/8	2.9	1.0
<b>9B</b>	SD	2-1/4	1-13/16	6.350	5/8	3-3/16	1-7/16	4-3/4	1-1/32	1-3/4	1-15/16	4.8	1.5
<b>10B</b>	SK	1-15/16	1-7/8	7.500	23/32	3-7/8	1-5/8	5-1/2	1-7/32	2	2-1/2	7.8	2.0
<b>11B</b>	SF	2-3/16	2	8.625	11/16	4-5/8	1-7/8	6-1/4	1-1/2	2-3/8	2-15/16	12.0	3.5
<b>12B</b>	E	2-23/32	2-5/8	10.000	29/32	6	2-5/16	7-1/2	1-11/16	2-11/16	3-1/2	18.0	9.0
<b>13B</b>	F	3-3/4	3-5/8	11.750	1-1/16	6-5/8	2-11/16	8-3/4	1-31/32	3	3-15/16	31.2	14.0
<b>14B</b>	F	3-3/4	3-5/8	13.875	1-1/16	6-5/8	3-1/4	9-7/8	2-1/4	3-1/2	3-15/16	51.4	14.0
<b>16B</b>	J	4-13/16	4-1/2	18.875	1-1/4	7-1/4	4-3/4	12-3/4	2-3/4	4-1/4	4-1/2	120.0	22.0

\* Maximum bore with keyseat. ■ Approximate weight for each flange.

# Type B Bushed - Flex QD

## For Close Coupled Applications

### COUPLINGS

Type B Sure-Flex Couplings are normally supplied with the two-piece E sleeve, and can use any EPDM or Neoprene sleeves. DO NOT use Hytrel sleeves with Type B couplings.

Spacing between internal flange-hubs equals L minus 2 times C. Spacing between shafts should be greater than 1/8 in. and less than G.

To order complete couplings, specify coupling size with flange symbol (B) and bushing. Refer to page F1N3 to order the required coupling. Refer to charts below for bushings.

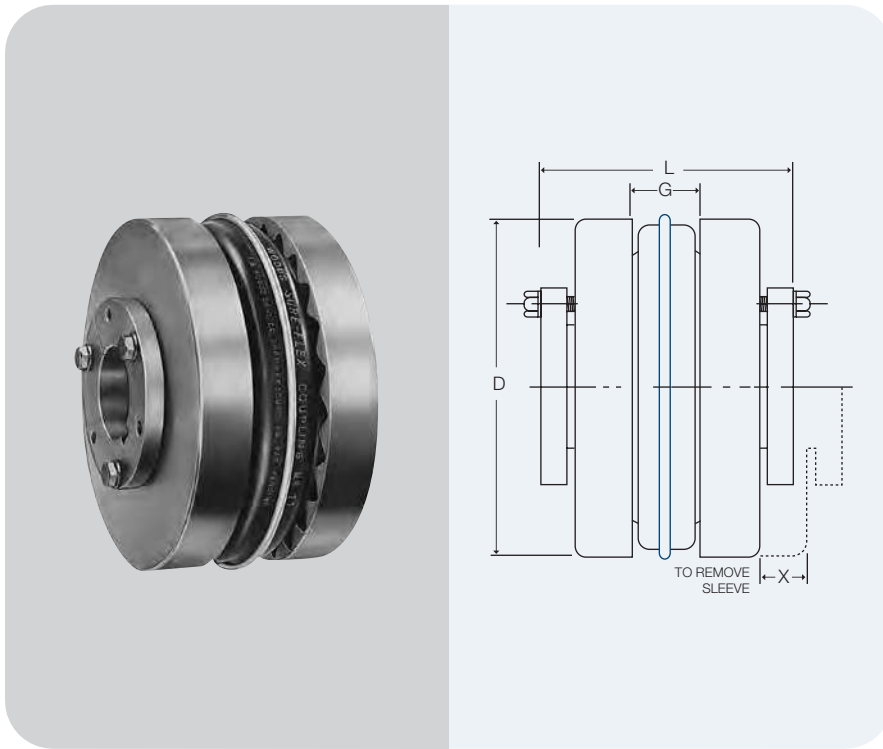

### SURE-GRIP® BUSHING KEYSEAT DIMENSIONS (in.)

Bushing	Bores	Keyseat
<b>JA</b>	1/2 - 1	Standard ②
	1-1/16 - 1-3/16	1/4 x 1/16
	1-1/4	1/4 x 1/32
<b>SH</b>	1/2 - 1 3/8	Standard ②
	1-7/16 - 1 5/8	3/8 x 1/16
	1-11/16	No K.S.
<b>SD</b>	1/2 - 1-11/16	Standard ②
	1-3/4	3/8 x 1/8
	1-13/16	1/2 x 1/8
	1-7/8 - 1-15/16	1/2 x 1/16
<b>SK</b>	2	No K.S.
	1/2 - 2-1/8	Standard ②
	2-3/16 - 2-1/4	1/2 x 1/8
<b>J</b>	2-5/16 - 2 1/2	5/8 x 1/16
	2-9/16 - 2 5/8	No K.S.

Bushing	Bores	Keyseat
<b>SF</b>	1/2 - 2-1/4	Standard ②
	2-5/16 - 2-1/2	5/8 x 3/16
	2-9/16 - 2-3/4	5/8 x 1/16
	2-13/16 - 2-7/8	3/4 x 1/16
<b>E</b>	2-15/16	3/4 x 1/32
	7/8 - 2-7/8	Standard ②
	2-5/16 - 3-1/4	3/4 x 1/8
<b>F</b>	3-5/16 - 3-1/2	7/8 x 1/16
	1 - 3-1/4	Standard ②
	3-5/16 - 3-3/4	7/8 x 3/16
	3-13/16 - 3-15/16	1 x 1/8
<b>J</b>	4	No K.S.
	1-7/16 - 3-13/16	Standard ②
	3-7/8 - 3-15/16	1 x 3/8
<b>J</b>	4 - 4-1/2	1 x 1/8

### ② Standard Keyseat Dimension

Shaft Dia.	Width	Depth
1/2 - 9/16	1/8	1/16
5/8 - 7/8	3/16	3/32
15/16 - 1-1/4	1/4	1/8
1-5/16 - 1-3/8	5/16	5/32
1-7/16 - 1-3/4	3/8	3/16
1-13/16 - 2-1/4	1/2	1/4
2-5/16 - 2-3/4	5/8	5/16
2-13/16 - 3-1/4	3/4	3/8
3-5/16 - 3-3/4	7/8	7/16
3-13/16 - 4-1/2	1	1/2
4-9/16 - 5-1/2	1-1/4	5/8
5-9/16 - 6-1/2	1-1/2	3/4

# Type SC Spacer Couplings BTS

## Conventional Spacer Design

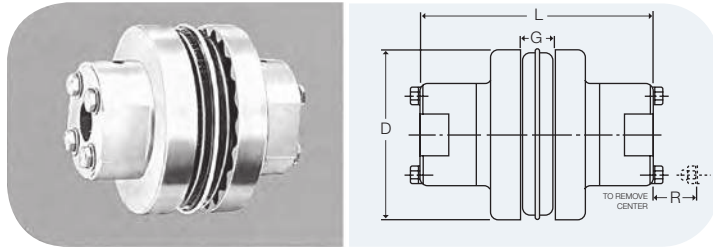

The table below shows assembled dimensions of Sure-Flex Type SC Spacer Couplings. For dimensions of separate components, refer to page F1 – 15.

Coupling Size	Required Distance Between Shafts	Use Flange No.	Use Hub No.	Max. Bore Std. KS	Dimensions				Wt. (lbs.) ■
					D	L <sup>(2)</sup>	G	R	
<b>4JSC</b>	3-1/2	4JSC35	-	1-1/8 <sup>(1)</sup>	2.460	5-5/8	5/8	-	2.7
<b>5SC</b>	3-1/2	5SC35	5SCH	1-1/8	3.250	5-5/8	3/4	9/16	4.5
<b>6SC</b>	3-1/2	6SC35	6SCH-6SCHS	1-3/8	4.000	5-7/8	7/8	3/4	7.3
	4-3/8	6SC44	6SCH-6SCHS	1-3/8	4.000	6-3/4	7/8	3/4	8.1
<b>7SC</b>	5	6SC50	6SCH-6SCHS	1-3/8	4.000	7-3/8	7/8	3/4	8.7
	3-1/2	7SC35	7SCH-7SCHS	1-5/8	4.625	6-3/8	1	5/8	9.9
	4-3/8	7SC44	7SCH-7SCHS	1-5/8	4.625	7-1/4	1	5/8	10.8
<b>8SC</b>	5	7SC50	7SCH-7SCHS	1-5/8	4.625	7-7/8	1	5/8	11.4
	3-1/2	8SC35	8SCH-8SCHS	1-7/8	5.450	6-7/8	1-1/8	13/16	15.2
	4-3/8	8SC44	8SCH-8SCHS	1-7/8	5.450	7-3/4	1-1/8	13/16	16.4
	5	8SC50	8SCH-8SCHS	1-7/8	5.450	8-3/8	1-1/8	1-3/16	17.4
<b>9SC</b>	5	8SC50-10	10SCH-10SCHS	2-3/8	5.450	9-5/8	1-1/8	1-3/16	27.2
	3-1/2	9SC35	9SCH-9SCHS	2-1/8	6.350	7-1/2	1-7/16	1-1/16	18.6
	4-3/8	9SC44	9SCH-9SCHS	2-1/8	6.350	8-1/4	1-7/16	1-1/16	22.2
	5	9SC50	9SCH-9SCHS	2-1/8	6.350	8-7/8	1-7/16	1-1/16	23.2
	7	9SC70-11	11SCH-11SCHS	2-7/8	6.350	10-3/8	1-7/16	1-3/16	40.4
<b>10SC</b>	7-3/4	9SC78-11	11SCH-11SCHS	2-7/8	6.350	13-1/8	1-7/16	1-3/16	51.0
	4-3/4	10SC48	10SCH-10SCHS	2-3/8	7.500	9-3/8	1-5/8	1-3/16	37.6
	5	10SC50	10SCH-10SCHS	2-3/8	7.500	9-5/8	1-5/8	1-3/16	38.4
	7	10SC70-13	13SCH-13SCHS	3-3/8	7.500	13-5/8	1-5/8	1-7/8	72.0
<b>11SC</b>	7-3/4	10SC78-13	13SCH-13SCHS	3-3/8	7.500	14-3/8	1-5/8	1-7/8	76.0
	10	10SC100-13	13SCH-13SCHS	3-3/8	7.500	16-5/8	1-5/8	1-7/8	88.0
	4-3/4	11SC48	11SCH-11SCHS	2-7/8	8.625	10-5/16	1-7/8	1-3/16	54.5
	5	11SC50	11SCH-11SCHS	2-7/8	8.625	10-3/8	1-7/8	1-3/16	54.7
	7	11SC70-14	14SCH	3-7/8	8.625	14-5/8	1-7/8	2	86.1
<b>12SC</b>	7-3/4	11SC78-14	14SCH	3-7/8	8.625	15-3/8	1-7/8	2	90.3
	10	11SC100-14	14SCH	3-7/8	8.625	17-5/8	1-7/8	2	102.7
	7	12SC70	12SCH-12SCHS	2-7/8	10.000	12-7/8	2-5/16	1-1/2	88.1
	7-3/4	12SC70-14	14SCH	3-7/8	10.000	14-5/8	2-5/16	2	99.1
	10	12SC78-14	14SCH	3-7/8	10.000	15-3/8	2-5/16	2	103.3
<b>13SC</b>	10	12SC100-14	14SCH	3-7/8	10.000	17-5/8	2-5/16	2	115.7
	7-3/4	13SC78	13SCH-13SCHS	3-3/8	11.750	14-3/8	2-11/16	1-7/8	129.6
<b>14SC</b>	7-3/4	14SC78	14SCH	3-7/8	13.875	15-3/8	3-1/4	2	179.9

■ Approximate weight for completely assembled spacer coupling.

(1) 4JSC35 x 1-1/8 has shallow keyseat. (2) "L" dimension and weight will change if one or two short (HS) hubs used.

Note: Refer to page F1 – 15 to order — specify components separately.

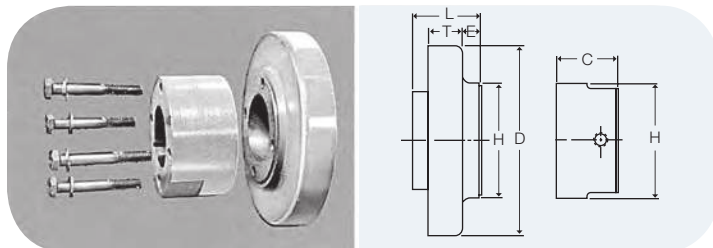

## TYPE SC FLANGES AND HUBS

Tables on page F1 – 15 provide dimensional information for flanges and hubs used for Spacer Couplings. For assembled dimensions, see table above. Any of the sleeves shown on page F1 – 5 may be used.



# Type SC Flanges And Hubs BTS

## Conventional Spacer Design

(ILLUSTRATION AND DIMENSIONAL DRAWINGS SHOWN AT BOTTOM OF PAGE F1 – 14.)

Coupling Size	Flange No.	For Distance Between Shafts*	For Hub	Dimensions					Wt. (lbs.)
				D	E	H	L	T	
4JSC	4JSC35	3-1/8	-	2.460	2-1/16	2	2-1/2	7/16	1.3
5SC	5SC35	3-1/2	5SCH	3.250	51/64	2	1-11/16	19/32	1.3
6SC	6SC35	3-1/2	6SCH-6SCHS	4.000	19/32	2-1/2	1-5/8	23/32	2.0
	6SC44	4-3/8	6SCH-6SCHS	4.000	1-1/32	2-1/2	2-1/16	23/32	2.4
	6SC50	5	6SCH-6SCHS	4.000	1-11/32	2-1/2	2-3/8	23/32	2.7
7SC	7SC35	3-1/2	7SCH-7SCHS	4.625	15/32	2-13/16	1-5/8	25/32	2.5
	7SC44	4-3/8	7SCH-7SCHS	4.625	29/32	2-13/16	2-1/16	25/32	3.0
	7SC50	5	7SCH-7SCHS	4.625	1-7/32	2-13/16	2-3/8	25/32	3.3
8SC	8SC35	3-1/2	8SCH-8SCHS	5.450	9/32	3-1/4	1-5/8	29/32	3.7
	8SC35-10	3-1/2	10SCH-10SCHS	5.450	9/32	4-3/8	1-5/8	29/32	3.5
	8SC44	4-3/8	8SCH-8SCHS	5.450	23/32	3-1/4	2-1/16	29/32	4.3
	8SC50	5	8SCH-8SCHS	5.450	1-1/32	3-1/4	2-3/8	29/32	4.8
	8SC50-10	5	10SCH-10SCHS	5.450	1-1/32	4-3/8	2-3/8	29/32	5.5
9SC	9SC35	3-1/2	9SCH-9SCHS	6.350	1/16	3-5/8	1-11/16	1-1/32	4.1
	9SC44	4-3/8	9SCH-9SCHS	6.350	7/16	3-5/8	2-1/16	1-1/32	5.9
	9SC50	5	9SCH-9SCHS	6.350	3/4	3-5/8	2-3/8	1-1/32	6.4
	9SC50-11	5	11SCH-11SCHS	6.350	3/4	5-1/4	2-3/8	1-1/32	7.0
	9SC70-11	7	11SCH-11SCHS	6.350	1-3/4	5-1/4	3-3/8	1-1/32	10.9
	9SC78-11	7-3/4	11SCH-11SCHS	6.350	2-1/8	5-1/4	3-3/4	1-1/32	12.3
10SC	10SC48	4-3/4	10SCH-10SCHS	7.500	11/32	4-3/8	2-1/4	1-7/32	9.8
	10SC50	5	10SCH-10SCHS	7.500	15/32	4-3/8	2-3/8	1-7/32	10.2
	10SC70-13	7	13SCH-13SCHS	7.500	1-15/32	6-1/8	3-3/8	1-7/32	14.5
	10SC78-13	7-3/4	13SCH-13SCHS	7.500	1-27/32	6-1/8	3-3/4	1-7/32	16.5
	10SC100-13	10	13SCH-13SCHS	7.500	2-31/32	6-1/8	4-7/8	1-7/32	22.5
11SC	11SC48	4-3/4	11SCH-11SCHS	8.625	1/32	5-1/4	1-1/2	1-1/2	12.5
	11SC50	5	11SCH-11SCHS	8.625	1/16	5-1/4	1-9/16	1-1/2	12.6
	11SC70-14	7	14SCH	8.625	1-1/16	6-1/2	2-9/16	1-1/2	16.3
	11SC78-14	7-3/4	14SCH	8.625	1-7/16	6-1/2	2-15/16	1-1/2	18.4
	11SC100-14	10	14SCH	8.625	2-9/16	6-1/2	4-1/16	1-1/2	24.6
12SC	12SC70	7	12SCH-12SCHS	10.000	21/32	5-3/4	2-15/32	1-11/16	23.4
	12SC70-14	7	14SCH	10.000	21/32	6-1/2	2-15/32	1-11/16	21.3
	12SC78	7-3/4	12SCH-12SCHS	10.000	1-1/32	5-3/4	2-27/32	1-11/16	25.3
	12SC78-14	7-3/4	14SCH	10.000	1-1/32	6-1/2	2-27/32	1-11/16	23.4
	12SC100-14	10	14SCH	10.000	2-5/32	6-1/2	3-31/32	1-11/16	29.6
13SC	13SC78	7-3/4	13SCH-13SCHS	11.750	9/16	6-1/8	3-1/4	1-31/32	38.4
14SC	14SC78	7-3/4	14SCH	13.875	1/32	6-1/2	2-23/32	2-1/4	55.2

\* Flanges can be mixed to form different Between-Shaft Dimensions. See chart page F1 – 16. ■ Approximate weight for each flange.

▲ If using 10HS hub, 7/16-14NC x 2-1/4 long capscrew needed (not furnished).

Coupling Size	Hub No.	Max. Bore	STOCK BORES *		Dimensions			Wt. (lbs.) ⑤
			Plain Bore	Bore with Standard Keyway & Set Screw	C	H	Cap Screws Furnished	
4JSC	†	1-1/8	-	5/8 – 7/8 – 1 – 1-1/8*	1-1/16	2	-	-
5SC	5SCH	1-1/8	1/2	5/8 – 3/4 – 7/8 – 1 – 1-1/8	1-3/32	2	4 – 10 x 1-1/2	.8
6SC	6SCH	1-3/8	5/8	3/4 – 7/8 – 1 – 1-1/8 – 1-1/4 – 1-3/8	1-7/32	2-1/2	4 – 1/4 x 1-3/4	1.4
	6SCHS	7/8	-	7/8	31/32	2-1/2	4 – 1/4 x 1-1/2	1.1
7SC	7SCH	1-5/8	5/8	7/8 – 1 – 1-1/8 – 1-3/8 – 1-1/2 – 1-5/8	1-15/32	2-13/16	4 – 1/4 x 1-7/8	2.0
	7SCHS	7/8	-	7/8	1-3/32	2-13/16	4 – 1/4 x 1-1/2	1.5
8SC	8SCH	1-7/8	3/4	7/8 – 1 – 1-1/8 – 1-3/8 – 1-1/2 – 1-5/8 – 1-3/4 – 1-7/8	1-23/32	3-1/4	4 – 5/16 x 2-1/4	3.2
	8SCHS	7/8	-	7/8	1-7/32	3-1/4	4 – 5/16 x 1-3/4	2.0
9SC	9SCH	2-1/8	7/8	1 – 1-1/8 – 1-3/8 – 1-1/2 – 1-5/8 – 1-3/4 – 1-7/8 – 2-1/8	1-31/32	3-5/8	4 – 3/8 x 2-3/4	4.2
	9SCHS	1-1/2	-	1-1/8	1-17/32	3-5/8	4 – 3/8 x 2-1/4	3.7
10SC	10SCH	2-3/8	1-1/8	1-5/8 – 1-7/8 – 2-1/8 – 2-3/8	2-11/32	4-3/8	4 – 7/16 x 3-1/4	7.4
	10SCHS	1-5/8	-	1-1/8	1-21/32	4-3/8	4 – 7/16 x 2-1/2	5.5
11SC	11SCH	2-7/8	1-1/8	1-7/8 – 2-1/8 – 2-3/8 – 2-7/8	2-23/32	5-1/4	4 – 1/2 x 3-1/2	12.2
	11SCHS	1-7/8	-	1-1/8 – 1-5/8	1-29/32	5-1/4	4 – 1/2 x 2-3/4	9.3
12SC	12SCH	2-7/8	1-3/8	2-1/8 – 2-3/8 – 2-7/8	2-31/32	5-3/4	4 – 5/8 x 4	16.6
	12SCHS	2-1/2	-	2-3/8	2-17/32	5-3/4	4 – 5/8 x 3-1/2	14.1
13SC	13SCH	3-3/8	1-3/8	2-3/8 – 2-7/8 – 3-3/8	3-11/32	6-1/8	4 – 5/8 x 4-1/2	19.9
	13SCHS	2-1/2	-	2-1/8 – 2-3/8	2-15/32	6-1/8	4 – 5/8 x 3-1/2	16.0
14SC	14SCH	3-7/8	1-5/8	2-3/8 – 2-7/8 – 3-3/8 – 3-7/8	3-27/32	6-1/2	4 – 5/8 x 5	24.2

† FOR 4JSC the hub is an integral part of the flange. 4JSC x 1-1/8 has 1/4 x 1/16 shallow keyseat. ■ Approximate weight for each hub.

\* See page F1 – 10 for bore tolerances F1 – 13 for std. keyseat dimensions

# Between Shaft Spacings

Spacer couplings are available having the most popular between shaft dimensions. Other spacings can be achieved by mixing flanges.

The “Standard” column provides spacings using identical flanges; the “Combination” column mixes flanges; the column headed “Semi-Spacer” uses one flange that is not made for spacer coupling applications and thus does not have a detachable hub.

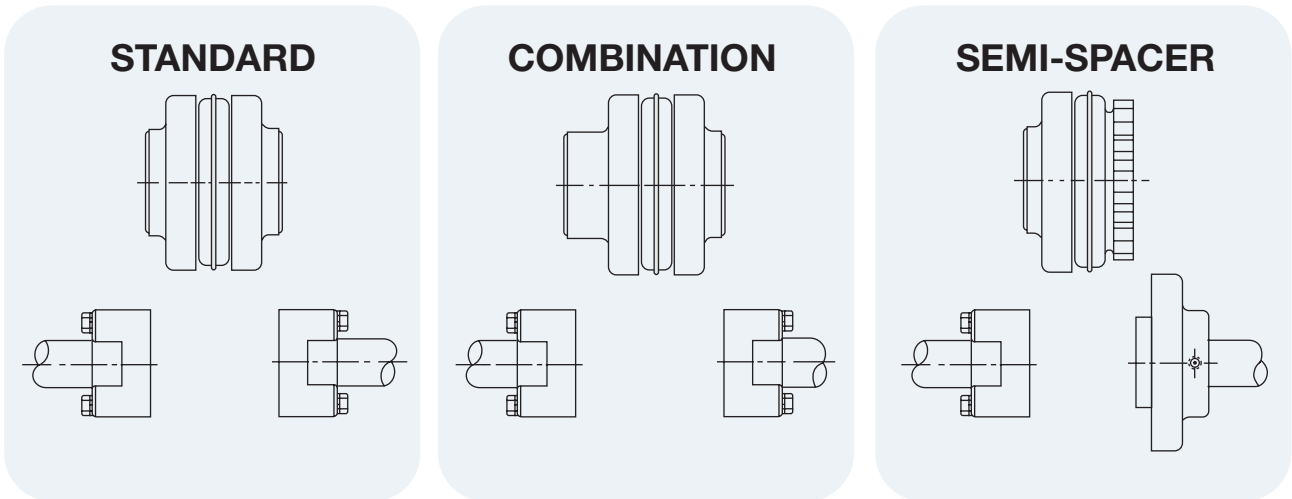

STANDARD	
Spacing	Use Flanges*
3-1/2	2-( ) SC35
4-3/8	2-( ) SC44
5	2-( ) SC50
7	2-( ) SC70
7-3/4	2-( ) SC78
10	2-( ) SC100

COMBINATION	
Spacing	Use Flanges*
3-15/16	SC35 & SC44
4-1/4	SC35 & SC50
4-11/16	SC44 & SC50
5-1/4	SC35 & SC70
5-5/8	SC35 & SC78
5-11/16	SC44 & SC70
6	SC50 & SC70
6-1/16	SC44 & SC78
6-3/8	SC50 & SC78
6-3/4	SC35 & SC100**
7-3/16	SC44 & SC100**
7-3/8	SC70 & SC78
7-1/2	SC50 & SC100
8-1/2	SC70 & SC100
8-7/8	SC78 & SC100

SEMI-SPACER	
Spacing	Use Flanges*
1-7/8	S & SC35
2-5/16	S & SC44
2-5/8	S & SC50
3-5/8	S & SC70
4	S & SC78
5-1/8	S & SC100

\* Check individual coupling size for flange availability.

\*\* Non-Stock

Note: Other combinations available — consult factory.

### CLAMP HUB – SPACER DESIGN

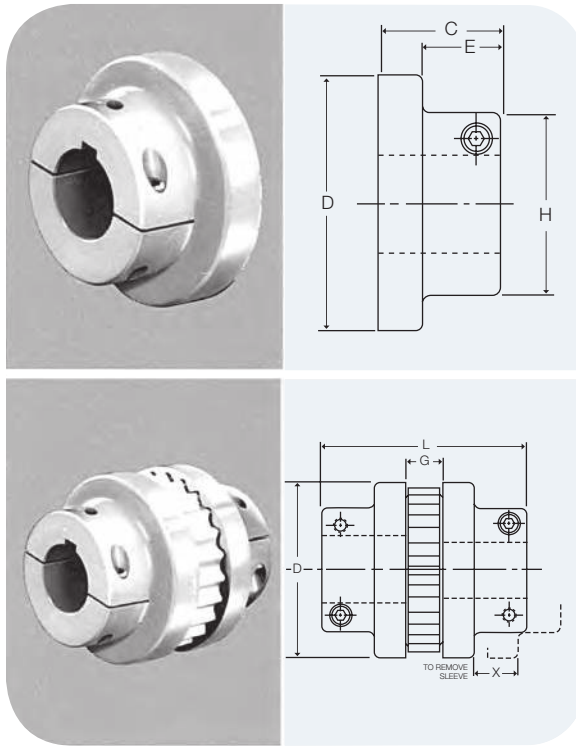

#### FLANGES

Sure-Flex® Type C Clamp Hub flanges employ integral locking collars and screws to assure a clamp fit on the shaft. One setscrew is furnished over the key. They are designed primarily for applications where flanges must be removed from one or both shafts without moving either the driver or driven units. A typical application is a screw compressor which uses a replaceable face seal around the input shaft.

#### COUPLINGS

Type C Clamp Hub Couplings normally use Hytrel sleeves. However, any of the sleeves shown on page F1-5 can be used. Type C couplings may often be used where spacer couplings are required.

Spacing between internal flange hubs equals G.

To order complete couplings, specify coupling size with flange symbol (C), giving bore required. Refer to page F1-3 to order the required coupling.

### DIMENSIONS (in.)

Flange Size	Stock Bores	Min. Bore	Maximum Bore		Distance Between Shafts		Dimensions							Approx. Wt. (lbs.)*
			Standard Keyseat	Shallow Keyseat	Min.	Max.	C	D	E	G	H	L	X	
6C	1-1/8, 1-7/8, 40mm	7/8	1-5/8	1-7/8	2	2 -3/4	1-15/16	4.000	1.16	7/8	3	4-3/4	1	2.6
7C	1-3/8, 1-7/8, 35mm, 40mm	1-1/8	1-7/8	-	2-5/16	3-7/16	2-3/16	4.625	1.41	1-1/16	3-1/4	5-7/16	1-3/16	3.6
8C	1-3/8, 1-5/8, 1-3/4, 1-7/8, 2-1/8, 2-1/4, 2-3/8, 40mm	1-3/8	2-1/4	2-3/8	2-9/16	4	2-1/2	5.450	1.59	1-1/8	3-7/8	6-1/8	1-3/8	6.5
9C	1-5/8, 1-3/4, 1-7/8, 2, 2-1/8, 2-1/4, 2-3/8, 2-1/2	1-5/8	2-1/2	2-11/16	3-1/16	4-5/8	3	6.350	1.97	1-7/16	4-1/4	7-7/16	1-9/16	9.8
10C	1-5/8, 1-7/8, 2-1/4, 2-3/8, 2-1/2	1-5/8	2-7/8	-	3-9/16	5-1/4	3-1/2	7.500	2.28	1-11/16	5	8-1 1/16	1-13/16	16.6
11C	2-1/8, 2-3/8, 2-1/2	1-7/8	3-3/8	-	4-1/8	5-7/8	4	8.625	2.5	1-7/8	5-3/8	9-7/8	2-1/8	26.0
12C	2-1/8	1-7/8	3-3/8	-	4-7/8	6-1/2	4-3/8	10.000	2.69	2-3/8	6	11-1/8	2-3/8	38.3

For Standard keyseat dimensions, see chart page F1 – 13. \* Weight of one flange.

#### Bore Tolerances for Type C Flanges

These bores provide a slip fit.

Bore (in.)	Tolerance (in.)
Up to and including 2"	+0.0005 to +0.0015
Over 2"	+0.0005 to +0.0020

#### Shallow Keyseat Dimensions

Some large bore Type C flanges are supplied with shallow keyseats. In these cases, a rectangular key is furnished. The flanges and bores involved are as follows:

Size	Bore Range	KS	Key Furnished
6C	1- 11 /16 to 1 -7/8	1/2 X 1/16	1/2 x 5/16 x 1-15/16
8C	2-5/16 to 2 -3/8	5/8 x 1/16	5/8 x 3/8 x 2-1/ 2
9C	2-7/16 to 2-11/16	5/8 x 3/16	5/8 x 1/2 x 3

# Sure-Flex® Couplings

## Installation Instructions

### Installation Instructions

Sure-Flex flanges (outer metallic parts) and sleeves (inner elastomeric members) come in many sizes and types. First, determine the size and type of components being used. Remove all components from their boxes, and loosely assemble the coupling on any convenient surface. (Do not attempt to install the wire ring on the two-piece E or N sleeve at this time.) Also check maximum RPM values in the table against operating speed. All rubber sleeves (EPDM and Neoprene) have the same ratings for a given size and may be used interchangeably. However, because rubber and Hytrel sleeves have completely different ratings, they never should be used interchangeably.

- 1 Inspect all coupling components and remove any protective coatings or lubricants from bores, mating surfaces and fasteners. Remove any existing burrs, etc. from the shafts.
- 2 Slide one coupling flange onto each shaft, using snugfitting keys where required. When using Type B flanges, follow the instructions furnished with the Sure-Grip bushing.
- 3 Position the flanges on the shafts to approximately achieve the Y dimension shown in the table. It is usually best to have an equal length of shaft extending into each flange. Move one flange to its final position. Torque fasteners to proper values. Slide the other flange far enough away to install the sleeve. With a two-piece sleeve, do not move the wire ring to its final position; allow it to hang loosely in the groove adjacent to the teeth.

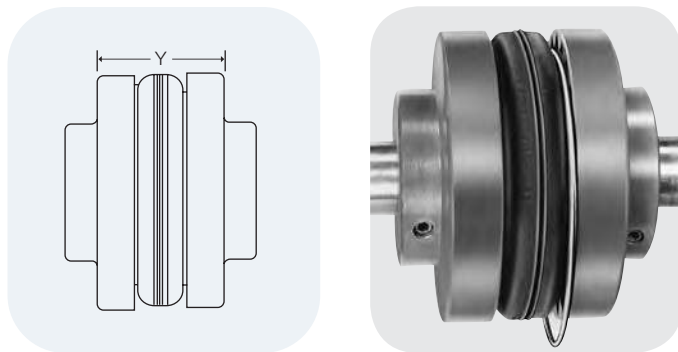

- 4 Slide the loose flange on the shaft until the sleeve is completely seated in the teeth of each flange. (The “Y” dimension is for reference and not critical.) Secure the flange to the shaft. Different coupling sleeves require different degrees of alignment precision. Locate the alignment values for your sleeve size and type in the table.

- 5 Check parallel alignment by placing a straight-edge across the two coupling flanges and measuring the maximum offset at various points around the periphery of the coupling without rotating the coupling. If the maximum offset exceeds the figure shown under “Parallel” in the table, realign the shafts.

- 6 Check angular alignment with a micrometer or caliper. Measure from the outside of one flange to the outside of the other at intervals around the periphery of the coupling. Determine the maximum and minimum dimensions without rotating the coupling. The difference between the maximum and minimum must not exceed the figure given under “Angular” in the table. If a correction is necessary, be sure to recheck the parallel alignment.



Parallel



Angular

MAXIMUM RPM AND ALLOWABLE MISALIGNMENT (Dimensions in inches)							
Sleeve Size	Maximum RPM	Types JE, JN, JES, JNS, E & N			*Type H, HS, Urethane		
		Parallel	Angular	Y	Parallel	Angular	Y
3	9200	.010	.035	1.188	-	-	-
4	7600	.010	.043	1.500	-	-	-
5	7600	.015	.056	1.938	-	-	-
6	6000	.015	.070	2.375	.010	.016	2.375
7	5250	.020	.081	2.563	.012	.020	2.563
8	4500	.020	.094	2.938	.015	.025	2.938
9	3750	.025	.109	3.500	.017	.028	3.500
10	3600	.025	.128	4.063	.020	.032	4.063
11	3600	.032	.151	4.875	.022	.037	4.875
12	2800	.032	.175	4.688	.025	.042	5.688
13	2400	.040	.195	6.688	.030	.050	6.625
14	2200	.045	.242	7.750	.035	.060	7.750
16	1500	.062	.330	10.250	-	-	-

**Note:** Values shown above apply if the actual torque transmitted is more than 1/4 the coupling rating. For lesser torque, reduce the above values by 1/2.

\*Type H and HS sleeves should not be used as direct replacements for EPDM or Neoprene sleeves.

- 7 If the coupling employs the two-piece sleeve with the wire ring, force the ring into its groove in the center of the sleeve. It may be necessary to pry the ring into position with a blunt screwdriver.

- 8 Install coupling guards per OSHA requirements.

**CAUTION: Coupling sleeves may be thrown from the coupling assembly with substantial force when the coupling is subjected to a severe shock load or abuse.**



# Dura-Flex® Couplings

## F2



Patent No. 5,611,732

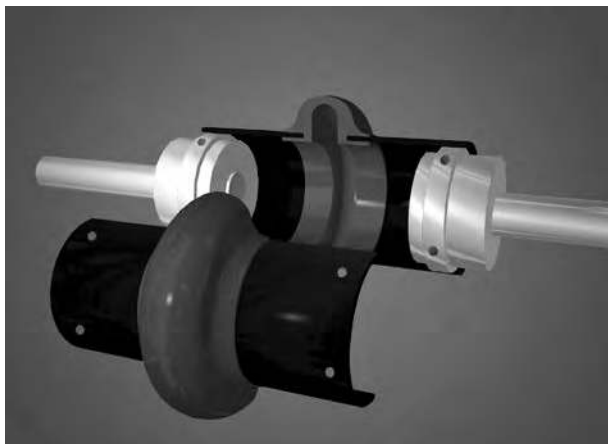

The specially designed split-in-half element can be easily replaced without moving any connected equipment.

## FEATURES

- Designed from the ground up using finite element analysis to maximize flex life.
- Easy two piece element installation. No need to move the hubs during replacement.
- One spacer size to handle most different between shaft spacings.
- Light weight element absorbs shock loading and torsional vibration.
- Same hubs used on both spacer and standard elements.
- No lubrication.
- Good chemical resistance.
- Stock bore-to-size (BTS), Sure-Grip bushed (QD) and Taper-Lock® bushed (TL) Hubs.

® Taper-Lock is a registered trademark of Rockwell Automation-Dodge.

# Dura-Flex® Coupling

## Selection

### A. Determine the Prime Mover Classification

Prime Mover	Class
• Electric Motors (Standard duty), Hydraulic Motors, Turbines	A
• Gasoline or Steam Engines (4 or more cylinders)	B
• Diesel or Gas Engines, High Torque Electric Motors	C

### B. Determine the Load Characteristics and the Service Factor

Typical Applications	Load	Characteristics	Prime Mover Class		
			A	B	C
Agitators (pure liquids), Blowers (centrifugal, Can and Bottle Filling Machines, Conveyors - uniformly loaded or fed (belt, chain, screw), Fans (centrifugal), Generators (uniform load), Pumps (centrifugal), Screens (air washing, water), Stokers (uniform load), Woodworking Machines (planers, routers, saws)	Uniform	Even loads - no shock - non reversing - infrequent starts (up to 10 per hour) - low starting torques	1.0	1.5	2.0
Beaters, Blowers (lobe, vane), Compressors (centrifugal, rotary), Conveyors - non uniformly loaded or fed (belt, bucket, chain, screw), Dredge Pumps, Fans (forced draft, propeller), Kilns, Paper Mills (calendars, converting machines, conveyors, dryers, mixers, winders), Printing Presses, Pumps (gear, rotary), Shredders, Textile Machinery (dryers, dyers)	Moderate shock	Uneven loads - moderate shock Infrequent reversing-moderate torques	1.5	2.0	2.5
Cranes (bridge, hoist, trolley), Fans (cooling tower), Generators (welding), Hammer Mills, Mills (ball, pebble, rolling, tube, tumbling), Pumps (oil well), Wire Drawing Machines	Heavy shock	Uneven loads - heavy shock - frequent starts and stops - high starting torques -high inertia peak loads	2.0	2.5	3.0

**Note:** The above applications depict the generally accepted conditions encountered in industry. Conditions subject to extreme-temperatures, abrasive dusts, corrosive liquids, excessively high starting torques, etc., must be considered as extra heavy shock loads. These conditions will increase service factors. Consult TB Wood's for these selections.

### C. Calculate Design Horsepower or Design Torque

- If Prime Mover is a 1160, 1750, or 3500 rpm motor.  
Design Hp = Prime Mover HP x Service Factor  
Go to page F2—3 and reference the corresponding motor rpm column.
- If Prime Mover is not one of the three speeds listed above.  
Design HP @ 100 rpm = (Primer Mover Hp x Service Factor x 100) / Coupling RPM  
Go to page F2—3 and reference HP @ 100 RPM column.
- If Using Prime Mover Torque  
Design Torque = Prime Mover Torque x Service Factor  
Go to page F2—3 and reference Torque column.

### D. Select Coupling (DURA-FLEX Couplings are sold by component)

A DURA-FLEX Assembly consists of one element (STD or Spacer) and two hubs (BTS or QD). Optional high speed rings may also be ordered for spacer elements. Below is an ordering example for Dura-Flex Couplings.

	Part #	Description	Size 20 Example
Element (1)	WE2 - WE80	Standard element, sizes 2 through 80	WE20
	WES2 - WES80	Spacer element, sizes 2 through 80	WES20
Hubs (2)	WE[2-80] x Bore	BTS hubs - stock bore (specify bore size)	WE20H138
	WE[4-80] - Bushing	QD hubs (sizes 4 through 80, bushing not included)	WE20H
	WE[3-80] - TL Bushing	TL hubs (sizes 3 through 80, bushing not included)	WE20HTL
HS Rings (1)	WE[20-80]R	High speed rings - sizes 20-80 (standard for sizes 2-10)	WE20R

### COUPLING RATINGS (STD & SPACER)

Coupling Size	HP@RPM				Torque (IN LBS)	Stiffness in lbs/Radian	Maximum RPM		Max. Misalignment	
	1000	1160	1750	3500			Standard	Spacer	Parallel	Angular
WE2	.30	3.50	5.28	10.55	190	3170	7500	7500	1/16	4°
WE3	.58	6.72	10.13	20.27	365	4710	7500	7500	1/16	4°
WE4	.88	10.12	15.27	30.54	550	5370	7500	7500	1/16	4°
WE5	1.48	17.02	25.68	51.37	925	9820	7500	7500	1/16	4°
WE10	2.30	26.69	40.26	80.52	1450	15800	7500	7500	1/16	4°
WE20	3.65	42.33	63.86	127.73	2300	27600	6600	4800	3/32	3°
WE30	5.79	67.18	101.35	202.70	3650	42200	5800	4200	3-32	3°
WE40	8.85	101.23	152.72	305.43	5500	65200	5000	3600	3/32	3°
WE50	12.14	140.80	212.42	424.83	7650	123000	4200	3100	3-32	3°
WE60	19.84	230.07	347.08	694.17	12500	167000	3800	2800	1/8	2°
WE70	35.12	407.39	614.60	1229.20	22125	205000	3600	2600	1/8	2°
WE80	62.70	727.32	1097.30	2194.50	39500	305000	2000	1800	1/8	2°

\*Maximum spacer RPM = Maximum standard RPM if using optional high speed rings. Operating temperature range is -40 F to 200 F.

### BTS HUBS - STOCK BORES

BORE SIZE	PRODUCT NO.*	WE2H	WE3H	WE4H	WE5H	WE10H	WE20H	WE30H	WE40H	WE50H	WE60H	WE70H	WE80H
1/2	12	OS	OS										
5/8	58	X	X	OSX									
3/4	34	XS	XS		OS								
7/8	78	XS	XS	XS	X	OS	OS						
15/16	15/16			X									
1	1	XS	XS	XS	X	X	X	OS	OS				
1-1/16	1116				X								
1-1/8	118	XS	XS	XS	XS	XS	XS	X					
1-3/16	1316			X	X								
1-1/4	114		XS	X	X	X	XS			O			
1-5/16	1516			X	X								
1-3/8	138		XS	XS	XS	XS	XS	XS					
1-7/16	1716			X	X	X							
1-1/2	112			X	X	X	XS	XS	XS				
1-9/16	1916			X									
1-5/8	158			XS	XS	XS	XS	XS	XS		O		
1-11/16	11116			X	X	X	X	X					
1-3/4	134				X	X	XS	XS	XS	X			
1-7/8	178				XS	XS	XS	XS	XS	X			
1-15/16	11516					X	X						
2	2					S	X	XS					
2-1/8	218					X	XS	XS	X	X	X	O	
2-3/16	2316						X						
2-1/4	214						XS	XS	X	X			
2-3/8	238						XS	XS	XS	X	X	X	O
2-1/2	212							XS	X				
2-5/8	258											X	
2-3/4	234							XS	XS				
2-7/8	278							XS	XS	X	X	X	X
3-3/8	338								XS	X	X	X	X
3-3/4	334												X
3-7/8	378										X	X	X
4	4										X		
4-3/8	438											X	
4-7/8	478												X
<b>MAX BORE</b>		1-1/8	1-3/8	1-11/16	1-7/8	2-1/8	2-3/8	2-7/8	3-3/8	3-5/8	4	4-1/2	6

O NO KEYSEAT

X STANDARD KEYSEAT

S STEEL HUB OPTION

MAX. BORE INCLUDES STANDARD KEYSEAT

\* **PRODUCT NUMBER EXAMPLE** → WE5H114 for WE5 x 1-1/4 HUB  
WE5HS118 for WE5 x 1-1/8 STEEL HUB

### BORE TOLERANCES (BTS)

BORE SIZE	TOLERANCE
UP TO AND INCLUDING 2"	+ .0005 to + .0015
OVER 2"	+ .0005 to + .0020

# Dura-Flex® BTS Couplings

## Dimensions

### Assembly Dimensions for BTS Couplings.

(All dimensions in inches) Minimum Shaft Spacing = .25"

### Dimensions Common to BTS Standard and Spacer Assemblies

SIZE	A	B	C	Max. Bore
WE2 & WES2	3.70	1.85	0.94	1-1/8
WE3 & WES3	4.24	2.32	1.50	1-3/8
WE4 & WES4	4.52	2.6	1.69	1-5/8
WE5 & WES5	5.40	3.13	1.75	1-7/8
WE10 & WES10	6.48	3.65	1.88	2-1/8
WE20 & WES20	7.36	4.48	2.06	2-3/8
WE30 & WES30	8.41	5.42	2.31	2-7/8
WE40 & WES40	9.71	6.63	2.50	3-3/8
WE50 & WES50	11.34	8.13	2.75	3-5/8
WE60 & WES60	12.53	8.75	3.25	4
WE70 & WES70	14.00	9.25	3.62	4-1/2
WE80 & WES80	16.00	11.3	4.98	6

### Standard Element Assembly

Product No.*	OAL MAX	OAL MIN	Maximum DBSE	Weight lbs.
WE2	3.78	3.22	1.90	1.5
WE3	4.32	3.80	1.32	3.3
WE4	4.68	3.82	1.30	4.4
WE5	5.30	4.32	1.80	7.4
WE10	5.57	4.33	1.81	11.2
WE20	6.82	4.62	2.70	16.3
WE30	7.61	5.19	2.99	27.7
WE40	8.16	5.56	3.16	45.4
WE50	9.21	6.13	3.71	59.0
WE60	10.70	7.20	4.20	82.6
WE70	11.88	8.24	4.64	109.0
WE80	16.60	10.48	6.64	242.0

\* Product number is element only.

### Spacer Element Assembly

Product No.*	OAL MAX	OAL MIN	Maximum DBSE	Weight lbs.
WES2	5.92	5.72	4.04	2.5
WES3	8.02	7.50	5.02	4.8
WES4	8.38	7.52	5.00	6.1
WES5	8.50	7.52	5.00	9.4
WES10	8.76	7.52	5.00	13.6
WES20	11.17	9.35	7.05	19.2
WES30	11.65	9.35	7.03	31.0
WES40	11.89	9.35	6.89	48.9
WES50	12.31	9.35	6.81	63.5
WES60	16.28	12.78	9.78	91.0
WES70	16.81	13.17	9.57	128
WES80	19.73	13.61	9.77	258

\* Product number is element only.

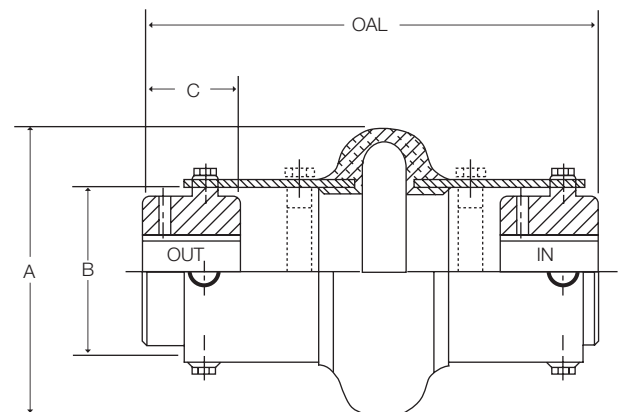
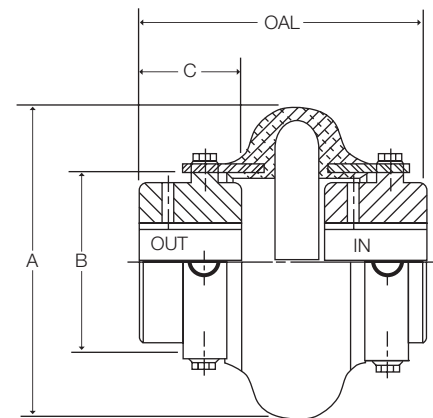

Sizes WES2 through WES10 are furnished with high speed rings. All larger sizes, rings can be ordered as an option.

All weights shown are with MPB style hubs.

Shaft Spacing from 1/4" up to the MAX DBSE can be accommodated by positioning hubs IN or OUT or by using various existing hole patterns.  
OAL - Over All Length does not include bolt heads

# Dura-Flex® QD Bushed Couplings

## Dimensions

### Assembly Dimensions for QD Bushed Couplings.

(All dimensions in inches) Minimum Shaft Spacing = .25"

#### Dimensions Common to QD Bushed Standard and Spacer Assemblies

SIZE	A	B	D	Bushing	Max. Bore
WE4 & WES4	4.52	2.60	1.00	JA	1-1/4
WE5 & WES5	5.40	3.13	1.25	SH	1-11/16
WE10 & WES10	6.48	3.65	1.31	SDS	2
WE20 & WES20	7.36	4.48	1.88	SK	2-5/8
WE30 & WES30	8.41	5.42	2.00	SF	2-15/16
WE40 & WES40	9.71	6.63	2.63	E	3-1/2
WE50 & WES50	11.34	8.13	2.63	E	3-1/2
WE60 & WES60	12.53	8.75	3.63	F	4
WE70 & WES70	14.00	9.25	4.50	J	4-1/2
WE80 & WES80	16.00	11.3	6.75	M	5-1/2

#### Standard Element Assembly

Product No.*	OAL MAX	OAL MIN	Maximum DBSE	Weight lbs.
WE4	3.88	3.24	1.88	3.8
WE5	4.50	4.24	2.00	6.0
WE10	5.07	3.83	2.45	8.8
WE20	6.62	4.38	2.86	15.9
WE30	6.19	5.43	2.19	25.1
WE40	7.00	6.50	1.74	47.0
WE50	8.13	6.61	2.87	48.0
WE60	9.00	8.68	1.74	79.4
WE70	10.86	10.12	1.86	124
WE80	15.10	13.97	1.60	268

\* Product number is element only.

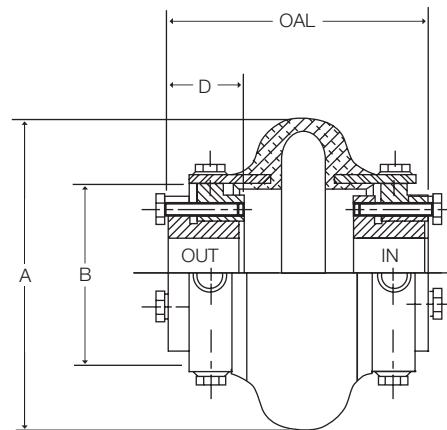

#### Spacer Element Assembly

Product No.*	OAL MAX	OAL MIN	Maximum DBSE	Weight lbs.
WES4	7.58	7.28	5.58	5.5
WES5	7.70	7.44	5.20	8.0
WES10	8.26	7.28	5.64	11.2
WES20	10.97	9.35	7.21	18.8
WES30	10.23	9.47	6.23	28.4
WES40	10.73	10.23	5.47	50.5
WES50	11.23	9.71	5.99	52.5
WES60	14.58	14.34	7.32	106.8
WES70	15.79	15.05	6.79	143
WES80	18.23	17.11	4.73	284

\* Product number is element only.

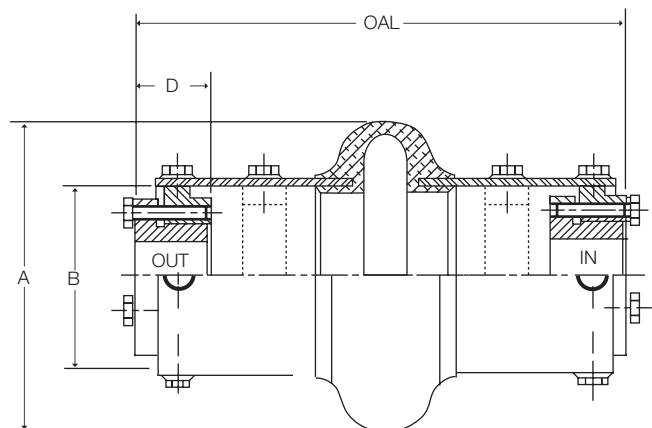

Sizes WES4 through WES10 are furnished with high speed rings. All larger sizes, rings can be ordered as an option.

All weights shown are with MPB bushings.

Shaft Spacing from 1/4" up to the MAX DBSE can be accommodated by positioning hubs IN or OUT or by using various existing hole patterns.

OAL - Over All Length does not include bolt heads

# Dura-Flex® Taper-Lock® Bushed Couplings

## Dimensions

### Assembly Dimensions for Taper-Lock® Bushed Couplings.

(All dimensions in inches) Minimum Shaft Spacing = .25"

### Dimensions Common to Taper-Lock® Bushed Standard and Spacer Assemblies

SIZE	A	B	H	Bushing	Max. Bore
WE3 & WES3	4.24	2.32	0.88	TL1008	1
WE4 & WES4	4.52	2.60	0.88	TL1008	1
WE5 & WES5	5.40	3.13	0.88	TL1108	1-1/8
WE10 & WES10	6.48	3.65	1.00	TL1310	1-7/16
WE20 & WES20	7.36	4.48	1.00	TL1610	1-11/16
WE30 & WES30	8.41	5.42	1.25	TL2012	2-1/8
WE40 & WES40	9.71	6.63	1.75	TL2517	2-11/16
WE50 & WES50	11.34	8.13	1.75	TL2517	2-11/16
WE60 & WES60	12.53	8.75	2.00	TL3020	3-1/4
WE70 & WES70	14.00	9.25	3.50	TL3535	3-15/16
WE80 & WES80	16.00	11.3	4.00	TL4040	4-7/16

### Standard Element Assembly

Product No.*	OAL	Maximum DBSE	Weight lbs.
WE3	3.44	1.68	1.8
WE4	3.44	1.68	2.6
WE5	3.94	2.18	4.0
WE10	4.07	2.07	6.0
WE20	4.50	2.50	9.0
WE30	5.07	2.57	13.6
WE40	5.88	2.38	21.8
WE50	6.51	3.01	31.5
WE60	7.32	3.32	46.6
WE70	9.42	2.42	66.7
WE80	11.72	3.72	82.0

\* Product number is element only.

### Spacer Element Assembly

Product No.*	OAL MAX	OAL MIN	Maximum DBSE	Weight lbs.
WES3	7.14	7.28	5.38	3.2
WES4	7.14	7.28	5.38	4.2
WES5	7.14	7.28	5.38	6.0
WES10	7.26	7.28	5.26	7.9
WES20	8.85	9.35	6.85	11.9
WES30	9.11	9.35	6.61	18.0
WES40	9.61	9.61	6.11	26.8
WES50	9.61	9.61	6.11	37.4
WES60	12.90	12.90	8.90	60.7
WES70	14.35	14.35	7.35	81.4
WES80	14.85	14.35	6.85	93.2

\* Product number is element only.

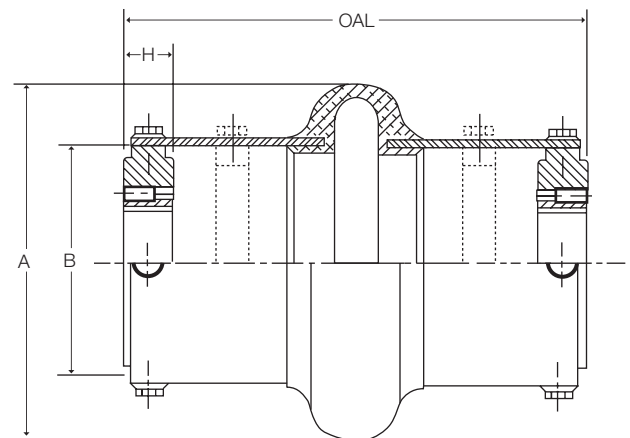
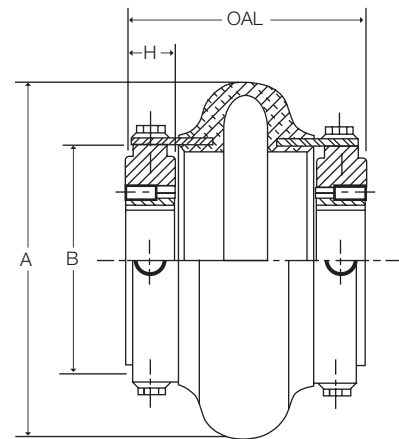

Sizes WES3 through WES10 are furnished with high speed rings. All larger sizes, rings can be ordered as an option.

All weights shown are with MPB bushings.

©Taper-Lock is a registered trademark of Rockwell Automation-Dodge.





Patent No. 5,611,732

## FEATURES

- Metric Hardware
- Designed from the ground up using finite element analysis to maximize flex life.
- Easy two piece element installation. No need to move the hubs during replacement.
- One spacer size to handle most different between shaft spacings.
- Light weight element absorbs shock loading and torsional vibration.
- Same hubs used on both spacer and standard elements.
- No lubrication.
- Good chemical resistance.

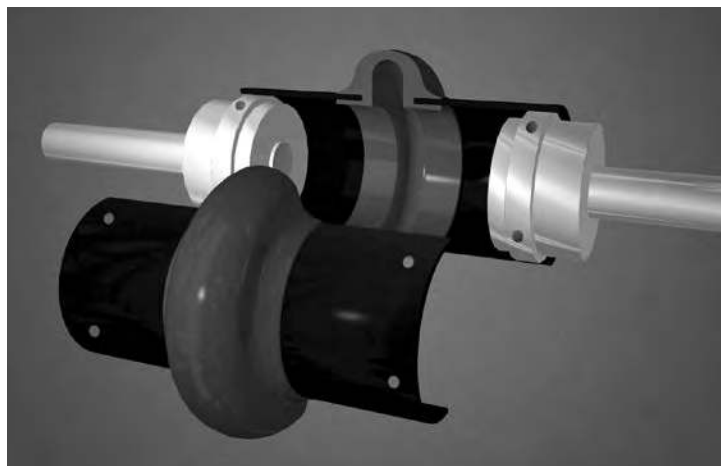

The specially designed split-in-half element can be easily replaced without moving any connected equipment.

# Dura-Flex® Metric Couplings

## Dimensions

### A. Determine the Prime Mover Classification

Prime Mover	Class
• Electric Motors (Standard duty), Hydraulic Motors, Turbines	A
• Gasoline or Steam Engines (4 or more cylinders)	B
• Diesel or Gas Engines, High Torque Electric Motors	C

### B. Determine the Load Characteristics and the Service Factor

Typical Applications	Load	Characteristics	Prime Mover Class		
			A	B	C
Agitators (pure liquids), Blowers (centrifugal, Can and Bottle Filling Machines, Conveyors - uniformly loaded or fed (belt, chain, screw), Fans (centrifugal), Generators (uniform load), Pumps (centrifugal), Screens (air washing, water), Stokers (uniform load), Woodworking Machines (planers, routers, saws)	Uniform	Even loads - no shock - non reversing - infrequent starts (up to 10 per hour) - low starting torques	1.0	1.5	2.0
Beaters, Blowers (lobe, vane), Compressors (centrifugal, rotary), Conveyors - non uniformly loaded or fed (belt, bucket, chain, screw), Dredge Pumps, Fans (forced draft, propeller), Kilns, Paper Mills (calendars, converting machines, conveyors, dryers, mixers, winders), Printing Presses, Pumps (gear, rotary), Shredders, Textile Machinery (dryers, dyers)	Moderate shock	Uneven loads - moderate shock Infrequent reversing-moderate torques	1.5	2.0	2.5
Cranes (bridge, hoist, trolley), Fans (cooling tower), Generators (welding), Hammer Mills, Mills (ball, pebble, rolling, tube, tumbling), Pumps (oil well), Wire Drawing Machines	Heavy shock	Uneven loads - heavy shock - frequent starts and stops - high starting torques - high inertia peak loads	2.0	2.5	3.0

**Note:** The above applications depict the generally accepted conditions encountered in industry. Conditions subject to extreme temperatures, abrasive dusts, corrosive liquids, excessively high starting torques, etc., must be considered as extra heavy shock loads. These conditions will increase service factors. Consult TB Wood's for these selections.

### C. Calculate Design Horsepower or Design Torque

- If Prime Mover is a 970, 1450, or 3000 rpm motor.  
Design KW = Prime Mover KW x Service Factor  
Go to page F2—9 and reference the corresponding motor rpm column.
- If Prime Mover is not one of the three speeds listed above.  
Design KW @ 100 rpm = (Prime Mover KW x Service Factor x 100) / Coupling RPM  
Go to page F2—9 and reference KW @ 100 RPM column.
- If Using Prime Mover Torque  
Design Torque = Prime Mover Torque x Service Factor  
Go to page F2—9 and reference Torque column.

## Dimensions

### D. DURA-FLEX Couplings are sold by component

A DURA-FLEX Assembly consists of one element (STD or Spacer) and two hubs (BTS or QD). Optional high speed rings may also be ordered for spacer elements. Below is an ordering example for Dura-Flex Couplings.

	Part #	Description	Size 20 Example
Element (1)	WE2M – WE80M	Standard Metric Element, sizes 2 through 80	WE20M
	WES2M – WES80M	Spacer Metric Element, sizes 2 through 80	WES20M
Hubs (2)	WE[2-80] HMPB	BTS Hubs – MPB suitable to rebore	WE20HMPB
	WE[3-80] HMTL Bushing	TL Hubs (sizes 3 through 80, bushing not included)	WE20HMTL
*HS Rings (1)	WE[20-80]RM	High speed rings – sizes 20-80 (standard for sizes 2-10)	WE20RM

\*Spacer element only

### COUPLING RATINGS (STD & SPACER)

Coupling Size	KW @ RPM				Torque (Nm)	Stiffness NM/RAD	Maximum Rpm		Max. Misalignment	
	100	970	1450	3000			Standard	Spacer *	Parallel (MM)	Angular
<b>WE2M</b>	0.22	2.17	3.24	6.71	22	358	7500	7500	1.6	4°
<b>WE3M</b>	0.43	4.20	6.27	12.98	41	532	7500	7500	1.6	4°
<b>WE4M</b>	.66	6.37	9.52	19.69	62	607	7500	7500	1.6	4°
<b>WE5M</b>	1.10	10.71	16.00	33.11	105	1110	7500	7500	1.6	4°
<b>WE10M</b>	1.72	16.64	24.87	51.45	164	1790	7500	7500	1.6	4°
<b>WE20M</b>	2.72	26.40	39.47	81.65	260	3120	6600	4800	2.4	3°
<b>WE30M</b>	4.32	41.88	62.61	129.53	412	4770	5800	4200	2.4	3°
<b>WE40M</b>	6.60	64.01	95.69	197.98	621	7370	5000	3600	2.4	3°
<b>WE50M</b>	9.05	87.81	131.27	271.58	864	13900	4200	3100	2.4	3°
<b>WE60M</b>	14.79	143.51	214.52	443.84	1412	18900	3800	2800	3.2	2°
<b>WE70M</b>	26.19	254.03	379.74	785.67	2500	23200	3600	2600	3.2	2°
<b>WE80M</b>	46.76	453.53	677.95	1402.66	4463	34500	2000	1800	3.2	2°

\*Maximum spacer RPM = Maximum standard RPM if using optional high speed rings

# Dura-Flex® Metric BTS Couplings

## Dimensions

### Assembly Dimensions for BTS Couplings.

(All dimensions in millimeters) Minimum Shaft Spacing = 6.35mm

### Dimensions Common to BTS Standard and Spacer Assemblies

SIZE	A	B	C	Max Bore
WE2M & WES2M	94	1.85	24	29
WE3M & WES3M	108	2.32	38	35
WE4M & WES4M	115	2.6	43	41
WE5M & WES5M	137	3.13	44	48
WE10M & WES10M	165	3.65	48	54
WE20M & WES20M	187	4.48	52	60
WE30M & WES30M	214	5.42	59	73
WE40M & WES40M	247	6.63	64	86
WE50M & WES50M	288	8.13	70	92
WE60M & WES60M	318	8.75	83	102
WE70M & WES70M	356	9.25	92	114
WE80M & WES80M	406	11.3	124	152

### Standard Element Assembly

Product No.	OAL MAX	OAL MIN	Maximum DBSE	Weight kg
WE2M	96	82	48	.07
WE3M	110	97	34	1.5
WE4M	119	97	33	2.0
WE5M	135	110	46	3.4
WE10M	141	105	46	5.1
WE20M	173	109	69	7.4
WE30M	193	118	76	12.6
WE40M	207	129	80	20.6
WE50M	234	147	94	26.8
WE60M	272	164	107	37.5
WE70M	279	183	123	49.4
WE80M	375	236	169	110

Product number is element only.

### Spacer Element Assembly

Product No.	OAL MAX	OAL MIN	Maximum DBSE	Weight kg
WES2M	145	145	103	1.1
WES3M	204	185	128	2.2
WES4M	213	185	127	2.8
WES5M	216	185	127	4.3
WES10M	223	185	127	6.2
WES20M	284	237	180	8.7
WES30M	296	237	180	14.1
WES40M	302	237	175	22.2
WES50M	313	237	173	28.8
WES60M	414	315	248	41.3
WES70M	427	318	243	58.1
WES80M	501	318	248	117.0

Product number is element only.

Shaft Spacing from 6.35 mm up to the MAX DBSE can be accommodated by positioning hubs IN or OUT or by using various existing hole patterns. OAL — Over All Length does not include bolt heads.

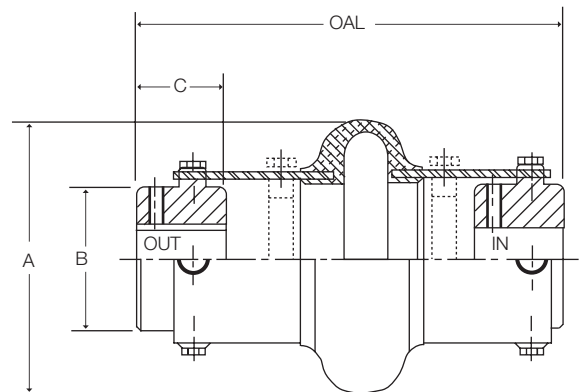
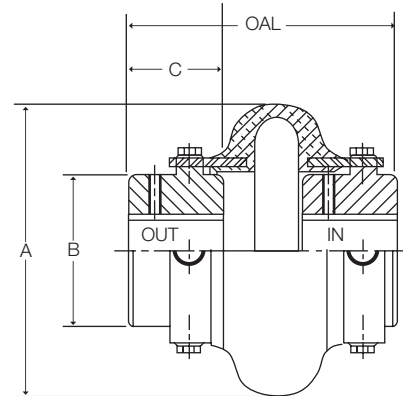

Sizes WES2M through WES10M are furnished with high speed rings. All larger sizes, rings can be ordered as an option.

All weights shown are with MPB style hubs.

# Dura-Flex® Metric Taper-Lock® Bushed Couplings

## Dimensions

### Assembly Dimensions for TAPER-LOCK® Bushed Couplings.

(All dimensions in millimeters) Minimum Shaft Spacing = 6.35 mm

### Dimensions Common to TAPER-LOCK® Bushed Standard and Spacer Assemblies

SIZE	A	B	H	Bushing	Max Bore
WE3M & WES3M	108	59	22	TL1008	26
WE4M & WES4M	115	66	22	TL1008	26
WE5M & WES5M	137	80	22	TL1210	32
WE10M & WES10M	165	93	25	TL1610	44
WE20M & WES20M	187	114	25	TL1610	44
WE30M & WES30M	214	138	32	TL2012	55
WE40M & WES40M	247	168	44	TL2517	68
WE50M & WES50M	288	207	44	TL2517	68
WE60M & WES60M	318	222	51	TL3020	82
WE70M & WES70M	356	235	89	TL3535	100
WE80M & WES80M	406	287	102	TL4040	113

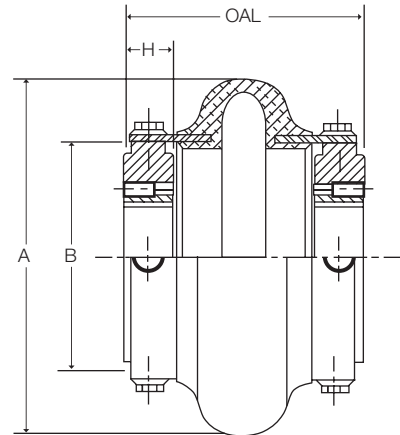

### Standard Element Assembly

Product No.	OAL	Maximum DBSE	Weight kg
WE3M	87	43	0.8
WE4M	87	43	1.2
WE5M	100	56	1.8
WE10M	103	52	2.7
WE20M	114	64	4.1
WE30M	129	65	6.2
WE40M	149	60	9.9
WE50M	165	76	14.3
WE60M	186	84	21.1
WE70M	238	60	30.3
WE80M	298	95	37.2

Product number is element only.

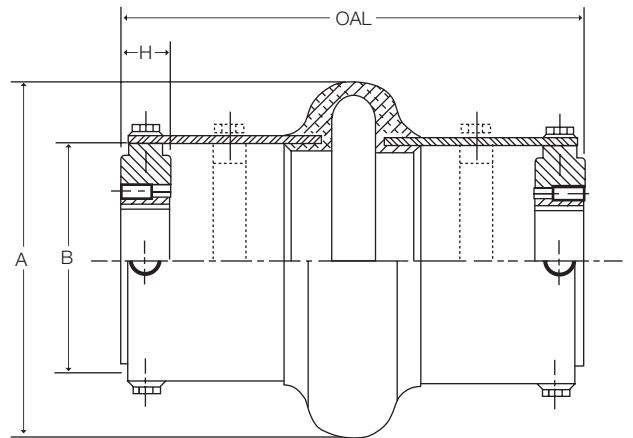

### Spacer Element Assembly

Product No.	OAL MAX	OAL MIN	Maximum DBSE	Weight kg
WES3M	185	185	137	1.5
WES4M	185	185	137	1.9
WES5M	185	185	137	2.7
WES10M	185	185	133	3.6
WES20M	237	237	174	5.4
WES30M	237	237	168	8.2
WES40M	244	237	155	12.2
WES50M	244	237	155	17.0
WES60M	328	315	226	27.5
WES70M	364	318	186	36.9
WES80M	377	318	174	42.3

Product number is element only.

© TAPER-LOCK: J.H. Fenner & Co. Limited, England.

Shaft Spacing from 6.35 mm up to the MAX DBSE can be accommodated by positioning hubs IN or OUT or by using various existing hole patterns.  
OAL — Over All Length does not include bolt heads.

Sizes WES3M through WES10M are furnished with high speed rings. All larger sizes, rings can be ordered as an option.

All weights shown are with MPB bushings.

# We Have A Product For All Your Coupling Needs

---

Besides the full line of stock DURA-FLEX couplings —  
Wood's has other stock coupling lines that may fill your application.

---



## Sure-Flex®

- Operates in shear
- No lubrication
- Four-way flexibility
- Easy installation

**Up to 115 HP  
@ 100 rpm**

---

## Gear Couplings

- High Torque Capacity
- Torsionally Stiff
- Good Inherent Balance
- Rated for Higher Speeds
- Many Types and Configurations

**Up to 2714 HP  
@ 100 rpm**



## Jaw Couplings

- Economical
- No maintenance
- Industry standard
- Large inventories

**Up to 30 HP  
@ 100 rpm**

---

## Form-Flex®

- All metal construction
- No lubrication
- Wide temperature range
- Zero backlash
- API offering

**Up to 3175 HP  
@ 100 rpm**





# Jaw Type Elastomeric Couplings

**F3**

## L-JAW



## Straight Jaw

- 100% interchangeable with industry standard
- 4 Insert materials available
- Large selection of sizes

## C-JAW

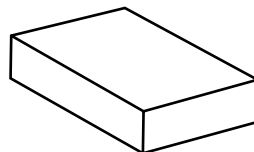

## Straight Jaw

- Uses individual cushions
- For higher torque loads
- Cushions easily replaced

# Jaw Couplings

## Selection

### Determine the Prime Mover Classification

Prime Mover	Class
• Electric Motors (Standard duty), Hydraulic Motors, Turbines	A
• Gasoline or Steam Engines (4 or more cylinders)	B
• Diesel or Gas Engines, High Torque Electric Motors	C

### Determine the Load Characteristics and the Service Factor

Typical Applications	Load	Characteristics	Prime Mover Class		
			A	B	C
Agitators (pure liquids), Blowers (centrifugal, Can and Bottle Filling Machines, Conveyors - uniformly loaded or fed (belt, chain, screw), Fans (centrifugal), Generators (uniform load), Pumps (centrifugal), Screens (air washing, water), Stokers (uniform load), Woodworking Machines (planers, routers, saws)	Uniform	Even loads - no shock - non reversing - infrequent starts (up to 10 per hour) - low starting torques — Up to 8 hours per day — Over 8 hours per day	1.0 1.5	1.5 2.0	2.0 2.5
Beaters, Blowers (lobe, vane), Compressors (centrifugal, rotary), Conveyors - non uniformly loaded or fed (belt, bucket, chain, screw), Dredge Pumps, Fans (forced draft, propeller), Kilns, Paper Mills (calendars, converting machines, conveyors, dryers, mixers, winders), Printing Presses, Pumps (gear, rotary), Shredders, Textile Machinery (dryers, dyers)	Moderate shock	Uneven loads - moderate shock Infrequent reversing-moderate torques — Up to 8 hours per day — Over 8 hours per day	1.5 2.0	2.0 2.5	2.5 3.0
Cranes (bridge, hoist, trolley), Fans (cooling tower), Generators (welding), Hammer Mills, Mills (ball, pebble, rolling, tube, tumbling), Pumps (oil well), Wire Drawing Machines	Heavy shock	Uneven loads - heavy shock - frequent starts and stops - high starting torques - high inertia peak loads — Up to 8 hours per day — Over 8 hours per day	2.0 2.5	2.5 3.0	3.0 3.5

**Note:** The above applications depict the generally accepted conditions encountered in industry. Conditions subject to extreme temperatures, abrasive dusts, corrosive liquids and dusts. Excessively high starting torques, etc., must be considered as extra heavy shock loads. These conditions will increase service factors. Consult factory for these selections.

### Calculate Design Horsepower or Design Torque

- If Prime Mover is a 1200, 1800, or 3600 rpm motor.  
Design Hp = Prime Mover HP x Service Factor  
Go to page F3—3 and reference the corresponding motor rpm column.
- If Prime Mover is not one of the three speeds listed above.  
Design Hp @ 100 rpm = (Prime Mover Hp x Service Factor x 100) / Coupling RPM  
Go to page F3—3 and reference HP @ 100 RPM column.
- If Using Prime Mover Torque  
Design Torque = Prime Mover Torque x Service Factor  
Go to page F3—3 and reference Torque column.

### Jaw Couplings are sold by component

Below is an ordering example for each Jaw style coupling.  
All listed components must be ordered to receive a complete coupling.

Components	L-JAW		C-JAW	
	Product No.	Description	Product No.	Description
<b>Driver Hub</b>	<b>L09958</b>	L099 x 5/8	<b>C280178</b>	C280 x 1-7/8
<b>Driven Hub</b>	<b>L09912NK</b> no keyseat	L099 x 1/2	<b>C280158</b>	C280 x 1-5/8
<b>Insert</b>	<b>L099N</b>	L099 Buna-N	<b>C280N</b> (contains 6 cushions)	C280 Buna-N
<b>Cover</b>	none	none	<b>C280CH</b> with hardware	C280 Cover

### L-JAW TYPE

PRODUCT NO.	MAX BORE	MAX RPM	BUNA-N SPIDER (N)					HYTREL SPIDER (H)				
			TORQUE IN. LBS	HP PER 100 RPM	HP/SPEEDS (RPM)			TORQUE IN. LBS	HP PER 100 RPM	HP/SPEEDS (RPM)		
					1200	1800	3600			1200	1800	3600
L035	3/8	31000	3.5	0.006	0.07	0.10	0.20					
L050	5/8	18000	26.3	0.042	0.50	0.75	1.50	50.0	0.079	0.95	1.43	2.86
L070	3/4	14000	43.2	0.069	0.82	1.23	2.47	114	0.181	2.17	3.26	6.51
L075	7/8	11000	90.0	0.143	1.71	2.57	5.14	227	0.360	4.32	6.48	12.97
L090	1	9000	144.0	0.228	2.74	4.11	8.23	401	0.636	7.64	11.45	22.91
1. L095	1-1/8	9000	194.0	0.308	3.69	5.54	11.08	561	0.890	10.68	16.02	32.04
L099	1-3/16	7000	318.0	0.505	6.05	9.08	18.16	792	1.257	15.08	22.62	45.24
2. L100	1-7/16	7000	417.0	0.662	7.94	11.91	23.82	1134	1.799	21.59	32.39	64.77
L110	1-5/8	5000	792.0	1.257	15.08	22.62	45.24	2268	3.599	43.18	64.77	129.55
L150	1-7/8	5000	1240.0	1.967	23.61	35.41	70.83	3708	5.883	70.60	105.90	211.80
L190	2-1/8	5000	1726.0	2.739	32.86	49.29	98.59	4680	7.426	89.11	133.66	267.32
L225	2-5/8	4600	2340.0	3.713	44.55	66.83	133.66	6228	9.882	118.58	177.87	355.74
L276	2-7/8	4200	4716.0	7.483	89.79	134.69	269.38					

BRONZE INSERTS HAVE SAME RATING AS HYTREL INSERTS.  
 URETHANE INSERTS RATINGS MULTIPLY BUNA-N INSERT BY 1.5.  
 1. USES L090 SPIDERS      2. USES L099 SPIDERS

**WARNING: DO NOT USE BRONZE INSERT OVER 250 RPM.**

### C-JAW TYPE

PRODUCT NO.	MAX BORE	MAX RPM	BUNA-N CUSHION SET (N)				
			TORQUE IN. LBS	HP PER 100 RPM	HP SPEEDS (RPM)		
					1200	1800	3600
C226	2-1/2	4800	2988.0	4.700	56.40	84.60	169.20
C276	2-7/8	4200	4716.0	7.500	90.00	135.00	270.00
C280	3	3500	7560.0	12.000	144.00	216.00	432.00
C285	4	3200	9182.0	14.600	175.20	262.80	525.60
C295	3-1/2	2300	11340.0	18.000	216.00	324.00	648.00
C2955	4	2300	18900.0	30.000	360.00	540.00	1080.00

### SPIDER CHARACTERISTICS

CHARACTERISTICS	BUNA-N (N)	URETHANE (U)	HYTREL (H)	BRONZE (B)
OIL RESISTANCE	GOOD	GOOD	EXCELLENT	EXCELLENT
CHEMICAL RESISTANCE	POOR	GOOD	EXCELLENT	EXCELLENT
FLEXIBILITY	EXCELLENT	GOOD	FAIR	POOR
TEMPERATURE RANGE	<b>F</b> <b>C</b> -40 TO +212 -40 TO +100	-30 TO +160 -35 TO +71	-60 TO +250 -51 TO +121	-40 TO +450 -40 TO +232
TORSIONAL STIFFNESS	FULL SOFT	MEDIUM SOFT	HARD	HARD
AVERAGE HARDNESS (SHORE NUMBER)	<b>80A</b>	<b>90A</b>	<b>55D</b>	-
MAX. MISALIGNMENT				
• ANGULAR	1°	1°	1/2°	1/2°
• PARALLEL	.015"	.015"	.015"	.010"
AVAILABILITY				
<b>L-JAW</b>	X	X	X	X
<b>C-JAW</b>	X			
COLOR	BLACK	BLUE	WHITE	BRONZE

TO ORDER SPIDER OR CUSHION SET SPECIFY THE COUPLING SIZE WITH THE MATERIAL SUFFIX.

EXAMPLE:  
 L150H = HYTREL SPIDER FOR L150 COUPLING

# Stock Bores

## Dimensions

### STOCK L-JAW INCH HUBS

BORE (IN.)	PRODUCT NO.	L035	L050	L070	L075	L090	L095	L099	L100	L110	L150	L190	L225	L276
1/8	18	0												
3/16	3/16	0												
1/4	14	X	X	X	X	X								
5/16	5/16	0	0	X	0	X								
3/8	38	X	X	X	X	X								
7/16	7/16		X	X	X	X	X	X	X					
1/2	12		X	X	X	X	X	X	X					
9/16	9/16		1	1	X	1	1	1	X					
5/8	58		X	X	1	1	1	1	1	X	X			
11/16	11/16			1	1	1	1	1	1					
3/4	34			1	1	X	1	1	1	1	1	X	X	
7/8	78				1	1	1	1	1	1	1	1	1	0
15/16	15/16					1	1	1	1	1	1	1	1	
1	1					1	1	1	1	1	1	1	1	
1-1/16	1116						1		1	1	1		1	
1-1/8	118						1	1	1	1	1	1	1	1
1-3/16	1316							1	1	1	1	1	1	
1-1/4	114								1	1	1	1	1	1
1-5/16	1516								1	1				
1-3/8	138								1	1	1	1	1	1
1-7/16	1716								1	1	1	1	1	
1-1/2	112									1	1	1	1	
1-9/16	1916									1	1		1	
1-5/8	158									1	1	1	1	
1-11/16	11116										1	1	1	
1-3/4	134										1	1	1	1
1-13/16	11316										1			
1-7/8	178										1	1	1	
1-15/16	11516											1	1	
2	2											1	1	1
2-1/16	2116													
2-1/8	218											1	1	1
2-3/16	2316												1	
2-1/4	214												1	1
2-3/8	238												1	
2-1/2	212												1	1
2-5/8	258												1	
2-7/8	278													1

0 NO KEYSEAT    1 STANDARD KEYSEAT    X NO KEYSEAT OR STANDARD KEYSEAT

Product Number Example → L09012 for L090 x 1/2 HUB

NOTE: L-JAW Hubs also available in aluminum – contact factory.

### BORE TOLERANCES

BORE SIZE	TOLERANCE
UP TO AND INCLUDING 2"	+ .0005
OVER 2"	+ .0015
	+ .0005
	+ .0020

### Standard Keyseat Dimensions

Shaft Dia.	Width	Depth
1/2 - 9/16	1/8	1/16
5/8 - 7/8	3/16	3/32
15/16 - 1-1/4	1/4	1/8
1-5/16 - 1-3/8	5/16	5/32
1-7/16 - 1-3/4	3/8	3/16
1-13/16 - 2-1/4	1/2	1/4
2-5/16 - 2-3/4	5/8	5/16
2-13/16 - 3-1/4	3/4	3/8
3-5/16 - 3-3/4	7/8	7/16
3-13/16 - 4-1/2	1	1/2
4-9/16 - 5-1/2	1-1/4	5/8
5-9/16 - 6-1/2	1-1/2	3/4

## Dimensions

### STOCK L-JAW METRIC BORE HUBS

BORE (MM)	PRODUCT NO.	L035	L050	L070	L075	L090	L095	L099	L100	L110	L150	L190	L225	L276
5	5	0												
6	6	1												
7	7		0											
8	8	0	0	0										
9	9													
10	10		X											
11	11		1		1									
12	12		1	1	1	1	1							
14	14		X	1	1	1	1	1	1					
15	15		1	1	1	1	1							
16	16			1	1	1	1		1					
17	17				1		1							
18	18				1	1	1		1	1				
19	19			1	1	1	1		1					
20	20				1	1	1	1	1	1	1			
22	22				1		1	1	1	1				
24	24					1	1	1	1	1				
25	25					1	1	1	1	1	1	1		
28	28						1	1	1	1				
30	30							1	1	1	1	1		
32	32								1	1	1		1	
35	35								1	1	1	1		
38	38									1	1	1	1	
40	40									1	1	1	1	
42	42									1	1	1	1	
45	45										1			
48	48										1	1		
50	50											1		
55	55													
60	60													1
65	65													1

0 No Keyseat    1 Standard Keyseat    X No Keyseat or Standard Keyseat

### C-Jaw Product Number Example:

<u>Item</u>	<u>Part No.</u>	<u>Description</u>
Hub	C226212	C226 x 2-1/2
Cushion	C226N	Cushion Kit
Cover	C226CH	Cover Kit

### BORE TOLERANCES

BORE SIZE	TOLERANCE
UP TO AND INCLUDING 2"	+ .0005
OVER 2"	+ .0015
	+ .0005
	+ .0020

### C-JAW HUBS

BORE SIZE	PRODUCT NO.	C226	C276	C280	C285	C295	C2955
SOLID	S						
1/8	18						
3/16	3/16						
1/4	14						
5/16	5/16						
3/8	38						
7/16	7/16						
1/2	12						
9/16	9/16						
5/8	58						
11/16	11/16						
3/4	34						
7/8	78	0	0				
15/16	15/16						
1	1						
1-1/16	1116						
1-1/8	118						
1-3/16	1316						
1-1/4	114			X	X		
1-5/16	1516						
1-3/8	138	1					
1-7/16	1716						
1-1/2	112	1				0	
1-9/16	1916						
1-5/8	158	1					
1-11/16	11116						
1-3/4	134	1	1				0
1-7/8	178	1	1				
1-15/16	11516						
2	2	1	1				
2-1/8	218	1	1	1			
2-1/4	214						
2-3/8	238	1	1	1			1
2-1/2	212			1			
2-5/8	258		1	1			1
2-7/8	278						1
3	3						
3-3/8	338						
3-1/2	312						
3-5/8	358						
3-3/4	334						
3-7/8	378						

### Standard Keyseat Dimensions

Shaft Dia.	Width	Depth
1/2 - 9/16	1/8	1/16
5/8 - 7/8	3/16	3/32
15/16 - 1-1/4	1/4	1/8
1-5/16 - 1-3/8	5/16	5/32
1-7/16 - 1-3/4	3/8	3/16
1-13/16 - 2-1/4	1/2	1/4
2-5/16 - 2-3/4	5/8	5/16
2-13/16 - 3-1/4	3/4	3/8
3-5/16 - 3-3/4	7/8	7/16
3-13/16 - 4-1/2	1	1/2
4-9/16 - 5-1/2	1-1/4	5/8
5-9/16 - 6-1/2	1-1/2	3/4

# L-Jaw And C-Jaw Couplings

## Dimensions

### L-JAW DIMENSIONS

Coupling Size	Hub Mat'l	DIMENSIONS					Weight Lbs*
		OD	HD	LTB	B	C	
L035	S.I.	0.63	0.63	0.27	0.81	0.28	0.10
L050	S.I.	1.08	1.08	0.63	1.72	0.47	0.30
L070	S.I.	1.36	1.36	0.75	2.00	0.50	0.60
L075	S.I.	1.75	1.75	0.81	2.13	0.50	1.00
L090	S.I.	2.11	2.11	0.81	2.13	0.50	1.50
L095	S.I.	2.11	2.11	1.00	2.50	0.50	1.80
L099	S.I.	2.53	2.53	1.06	2.88	0.75	2.50
L100	S.I.	2.53	2.53	1.38	3.50	0.75	3.50
L110	S.I.	3.33	3.33	1.69	4.23	0.85	6.60
L150	S.I.	3.75	3.75	1.75	4.50	1.00	9.10
L190	C.I.	4.50	4.00	1.94	4.88	1.00	17.00
L225	C.I.	5.00	4.25	2.19	5.38	1.00	23.00
L276	C.I.	6.19	5.00	3.13	7.88	1.63	47.00

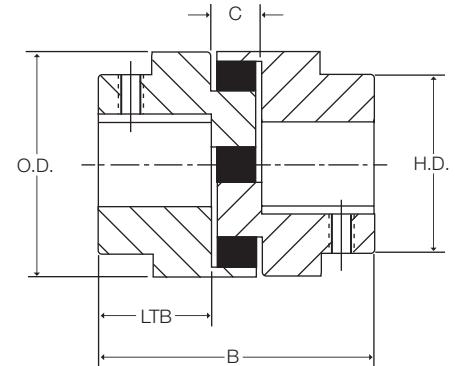

### C-JAW DIMENSIONS

Coupling Size	Hub Mat'l	DIMENSIONS					Weight Lbs*
		OD	HD	LTB	B	C	
C226	C.I.	5.15	4.12	2.75	7.00	1.50	29.00
C276	C.I.	6.18	5.00	3.12	7.87	1.63	47.00
C280	C.I.	7.50	5.50	3.12	7.87	1.63	61.00
C285	C.I.	8.50	6.50	3.75	9.13	1.63	87.00
C295	C.I.	9.12	6.31	3.75	9.38	1.88	97.00
C2955	C.I.	9.12	7.12	4.25	10.38	1.88	117.00

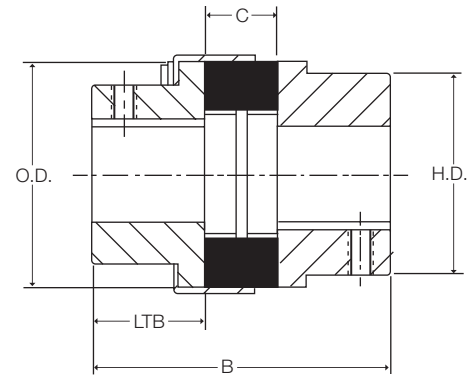

S.I. = Powdered metal • C.I. = Cast Iron

\*Weight of coupling assembly with minimum bores.

NOTE: L-JAW Hubs also available in aluminum – contact factory.



# G-Flex Grid Couplings

The Original Bibby  
Grid Coupling

**F4**



- Long Life
- Low Maintenance
- Design Flexibility

# G-Flex Grid Couplings

## Features

### Principal of Operation

Positive protection against the damaging effects of shock loads, impact loads and vibration.

The grid is torsionally flexible. The circumferential flexibility is progressive due to the curved profile of the grooves – ‘state-of-the-art’ in resilient coupling design.

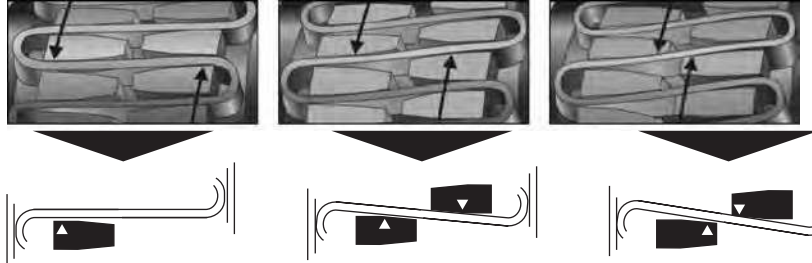

### Accommodating Shaft Misalignment and End-Float

The grid will accommodate combinations of misalignments present at set-up or occurring during machine displacement, settlement, etc.

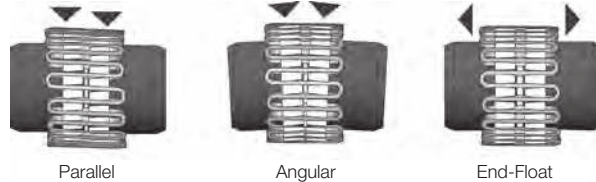

Limited End-Float kits are available on request.

### Effectiveness of Torsional Damping

As the grid coupling transmits torque, the flexing of the tapered grid spring damps vibrations and cushions shock loads.

This unique characteristic is due to the torsional flexibility of the coupling being proportionate to the unsupported length of each flexible grid rung. The resultant reduction in peak loading protects and extends the life of the transmission equipment.

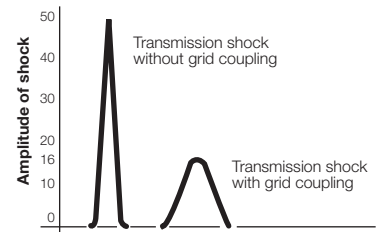

### Versatile Design

Both 1000T10 and 1000T20 couplings feature identical hubs and grid springs, the different cover styles provide great versatility – one is horizontally split “T10”, the other is vertically split “T20”.

All coupling components are designed to be interchangeable with other taper grid couplings. The stock coupling can be used vertically or horizontally without modification.

### Easy Installation and Maintenance

The grid springs are easily installed by hand or with a soft mallet. The cover fasteners can be tightened with standard wrenches. Every TB Wood’s coupling is delivered with detailed installation instructions. Periodic Lubrication of the coupling is required and each cover half is supplied with standard plugs which can be easily removed for re-lubrication.

### Recommended Fits between Shafts and Hubs

Coupling bore tolerances for sizes up to and including 1090T can be specified to suit a clearance fit with the shaft. In these instances the hub is provided with set screws. Relative positions are given in the following table.

#### “S” Position from Hub Faces

1020 = 1.2”	1060 = 2.0”
1030 = 1.3”	1070 = 2.1”
1040 = 1.5”	1080 = 2.5”
1050 = 1.7”	1090 = 2.8”

For sizes above 1090T or where interference fits are preferred for smaller coupling sizes, bore tolerances will be consistent with AGMA standards.

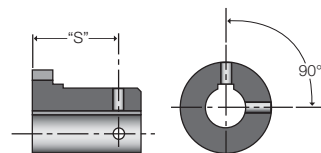

# Taper Grid Resilient Couplings

## Series 1000T10 And Series 1000T20

Dr. James Bibby originally invented the Resilient Coupling in 1917 and the 1000 Series is the latest level of this well accepted product. This Bibby Turboflex product has become universally accepted where reliable protection against shaft misalignment and vibration is desirable.

Since those early days refinements in design and material specifications have kept pace with advancing technology, achieving significant improvements in power/weight ratios.

TB Woods is proud to offer this proven product.



### 1000T10

- Horizontally Split Cover
- General Purpose
- Easy access to grid minimizes downtime
- Ideal for limited space applications
- Stop lug in cover prevents spinning during reversing service



### 1000T20

- Vertically Split Cover
- General purpose
- Ideal for higher running speeds

### High Performance

The TB Wood's Taper Grid Coupling continues that tradition. The tapered grid is made from high tensile alloy steel which is carefully formed to the grid shape before hardening and tempering under controlled conditions. The grid surface is then shot-peened. This process leaves the grid spring with a residually stressed surface layer which is in compression and which impedes the propagation of cracks. Since nearly all fatigue and stress corrosion failures originate at the surface of a part, the layer of compressive stress induced by shot-peening produces a dramatic increase in the working life and fatigue strength of the grid. This technological improvement in manufacturing process coupled with precise monitoring of raw material specification and control of trapezoidal shape, permits TB Wood's to offer state of the art grid springs of high performance and reliability.

### Scientific Design

The hub is precision manufactured from high quality materials, with the hub tooth profile scientifically designed to permit progressive loading under torsional shock conditions. The combination of tapered grid and precision manufactured hub provides easy assembly. The excellent shock absorption characteristics, and the ability to accommodate misalignment protects the connected equipment.

### Long Life

While the coupling is designed for long life under tough conditions, maintenance and taper grid replacement can be performed quickly and easily without the need to move and realign connected equipment. Two cover design options are available in the TB Wood's range of couplings. Both designs have been carefully engineered to provide a shaft coupling which is highly reliable and easy to install.

# Vertically Split Cover Couplings

## Series 1000T20

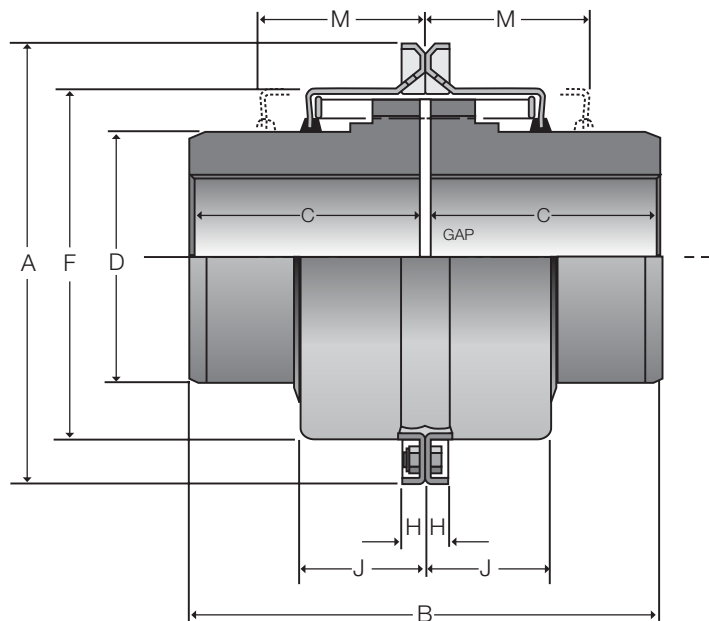

SIZE	COUPLING RATING (IN-LBS)	MAX RPM	MIN BORE (IN)	MAX BORE (IN)**	CPLG WT (LBS)*	WR2/ (LB/ FT2)*	DIMENSIONS IN INCHES								
							A	B	C	D	F	H	J	M	GAP
1020	460	6000	0.50	1.13	3.50	3.80	4.37	3.86	1.87	1.56	2.48	0.37	0.96	1.89	0.13
1030	1,319	6000	0.50	1.38	4.90	6.20	4.76	3.86	1.87	1.94	2.83	0.37	0.99	1.89	0.13
1040	2,204	6000	0.50	1.63	6.60	9.20	5.08	4.13	2.00	2.25	3.15	0.37	1.02	2.01	0.13
1050	3,850	6000	0.50	1.88	11.00	21.50	5.83	4.88	2.37	2.63	3.82	0.51	1.24	2.40	0.13
1060	6,054	6000	0.75	2.13	14.80	34.20	6.38	5.12	2.50	3.00	4.33	0.51	1.27	2.52	0.13
1070	8,798	5500	0.75	2.50	21.40	54.70	6.81	6.14	3.00	3.44	4.76	0.51	1.33	2.64	0.13
1080	18,144	4750	1.06	3.00	36.60	133.30	7.87	7.13	3.50	4.13	5.87	0.51	1.74	3.50	0.13
1090	33,013	4000	1.06	3.50	52.00	246.00	9.13	7.87	3.87	4.87	6.61	0.51	1.86	3.78	0.13
1100	55,582	3250	1.63	4.00	87.10	587.70	10.51	9.69	4.75	5.59	7.80	0.63	2.37	4.76	0.19
1110	82,489	3000	1.63	4.50	114.40	891.90	11.26	10.20	5.00	6.31	8.50	0.63	2.49	4.88	0.19
1120	121,255	2700	2.38	5.00	167.10	1708.60	12.56	12.01	5.87	7.06	9.69	0.63	2.91	5.63	0.25
1130	176,129	2400	2.63	6.00	253.50	3690.50	14.88	12.99	6.37	8.56	11.18	0.87	2.97	5.79	0.25
1140	253,130	2200	2.63	7.25	381.40	6475.40	16.38	14.76	7.25	10.00	12.68	0.87	3.09	6.14	0.25

\* Coupling weight and WR<sup>2</sup> with no bore

\*\* Max bore is for hub with keyway for rectangular key

# Horizontally Split Cover Couplings

## Series 1000T10

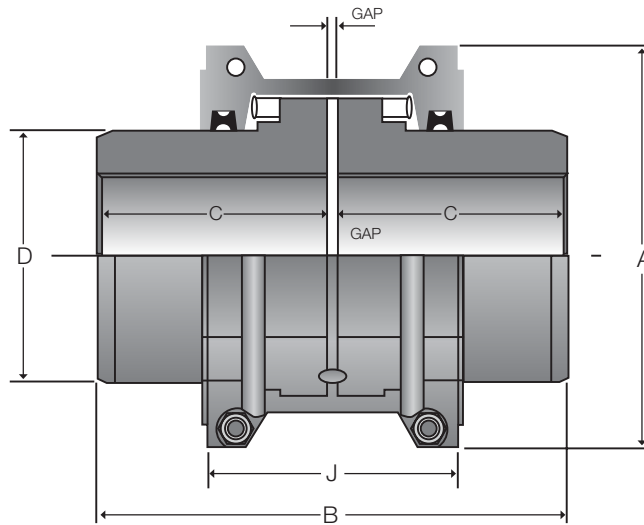

SIZE	COUPLING RATING (IN-LBS)	MAX SPEED	MIN BORE (IN)	MAX BORE (IN)**	CPLG WT (LBS)*	WR <sup>2</sup> / (LB/FT <sup>2</sup> )*	DIMENSIONS IN INCHES					
							A	B	C	D	J	GAP
1020	460	4500	0.50	1.13	4.00	4.80	4.02	3.86	1.87	1.56	2.64	0.13
1030	1,319	4500	0.50	1.38	5.30	7.50	4.37	3.86	1.87	1.94	2.68	0.13
1040	2,204	4500	0.50	1.63	7.10	11.30	4.65	4.13	2.00	2.25	2.76	0.13
1050	3,850	4500	0.50	1.88	11.50	23.90	5.43	4.88	2.37	2.63	3.11	0.13
1060	6,054	4350	0.75	2.13	15.70	41.00	5.94	5.12	2.50	3.00	3.62	0.13
1070	8,798	4125	0.75	2.50	22.30	61.50	6.38	6.14	3.00	3.44	3.74	0.13
1080	18,144	3600	1.06	3.00	39.00	153.80	7.64	7.13	3.50	4.13	4.57	0.13
1090	33,013	3600	1.06	3.50	54.00	268.90	8.39	7.87	3.87	4.87	4.80	0.13
1100	55,582	2440	1.63	4.00	91.00	615.10	9.88	9.69	4.75	5.59	6.14	0.19
1110	82,489	2250	1.63	4.50	118.20	922.60	10.63	10.20	5.00	6.31	6.42	0.19
1120	121,255	2025	2.38	5.00	173.50	1742.70	12.13	12.01	5.87	7.06	7.56	0.25
1130	176,129	1800	2.63	6.00	260.10	3382.90	13.66	12.99	6.37	8.56	7.68	0.25
1140	253,130	1650	2.63	7.25	388.00	6321.60	15.12	14.76	7.25	10.00	7.91	0.25

\* Coupling weight and WR<sup>2</sup> with no bore

\*\* Max bore is for hub with keyway for rectangular key

# Coupling Selection

---

## Procedure

Use the Application Service Factor table, Torque Rating and Maximum Coupling Bore Sizes tables to assist you in the selection procedure for products listed in this catalog. Contact TB Wood's technical staff to discuss any special requirements.

1. Select Service Factor (SF).  
From Table 1 (see page F4-8) and  
Table 1A (see page F4-9)

2. Calculate required minimum  
basic rating:

**a) Normal Service (Nominal Torque)**

$$\text{Basic Rating (in.lb.)} = \frac{\text{Transmitted Power (HP)} \times 63025 \times \text{SF}}{\text{RPM}}$$

**b) Repetitive High Peak Torque Applications** – See \*Note

**i. Non Reversing Duty**

$$\text{Selection Torque (in.lb.)} = \text{Nominal Torque (from a. above)}$$

$$\text{Selection Torque (in.lb.)} = 2 \times \text{Nominal Torque (from a. above)}$$

3. Select coupling having a basic rating equal to or exceeding the calculated value.
4. Check that speed does not exceed the coupling maximum speed.
5. Use Maximum Coupling Bore Sizes Table to determine Maximum Coupling Bore suitable for respective driving and driven shafts.

**\*Note:**

- The system peak torque is the maximum load created by the driving or driven equipment.
- Occasional peak torques of twice the catalog rating can be accommodated providing they occur less than 1000 times during the life of the coupling.

**Recommended fit between shafts and hubs**

Stock bore hubs are supplied with a clearance fit on sizes VP to and including 1090. Larger sizes are supplied with an interference fit.



# How To Select A Grid Coupling

The standard selection method can be used for most motor or engine driven applications. The following information is required to make a selection.

- 1 Power to be handled (HP) - P
- 2 (Alternative to Power is Torque (in.lb.) - T
- 3 Speed of operation (rpm) - N
- 4 Distance between the Shaft Ends - DBSE
- 5 Shaft Diameters for Driver & Driven Machines - D1 & D2

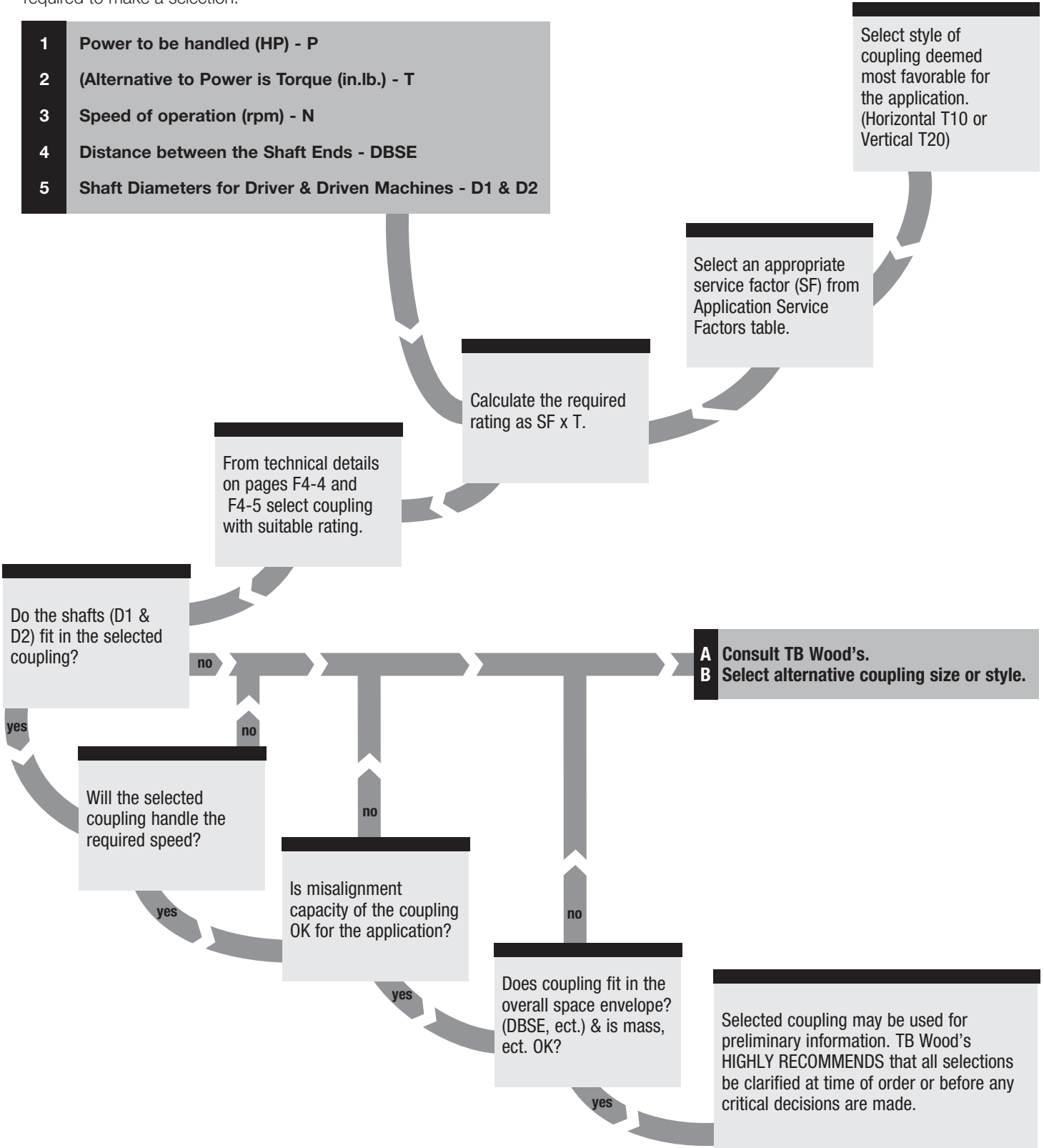

# Application Service Factors

**Table 1**

Application	Service Factor	Application	Service Factor	Application	Service Factor
<b>Agitators</b> .....	1.0	<b>Laundry Machines</b> .....	2.0	<b>Rubber Industry</b>	
<b>Blowers</b>		<b>Machine Tools</b>		Extruder .....	1.75
Centrifugal .....	1.0	Main drives .....	1.5	Calender .....	2.0
Lobe/Vane .....	1.25	Notching press/Planer/Punch .....	1.75	Bunbury mixer/Cracker/Mixing .....	
<b>Clay Working Machines</b>		Auxiliary and traverse drives .....	2.0	mill/Plasticator/Refiner .....	2.5
Brick press, Pug mill, Briquette machine ..	1.75	<b>Metalworking</b>		<b>Steel Industry</b>	
<b>Compressors</b>		Presses .....	2.0	Soaking pit/Cover drive:	
Centrifugal .....	1.0	Hammers .....	2.0	Lift .....	1.0
Lobe/Rotary .....	1.25	Straighteners .....	2.0	Travel .....	2.0
<b>Reciprocating</b>		Bending .....	1.5	Coilers (up or down) cold mills only .....	1.5
1 to 3 cylinders .....	3.0	Shears .....	1.5	Coilers (up or down) hot mills only .....	2.0
4 or more cylinders .....	1.75	Punching .....	2.0	<b>Coke Plants</b>	
<b>Conveyors</b>		<b>Mills (Rotary type)</b>		Pusher rain drive .....	2.5
<b>Uniformly fed horizontal:</b>		Ball or pebble .....	2.0	Door opener .....	2.0
Screw, Apron, Assembly, Belt, Chain,		Rod or tube .....	2.0	Pusher and Lorry car traction drive .....	3.0
Flight, Oven .....	1.0	Dryer and cooler .....	1.75	Cold mills – Strip and temper mills .....	2.0
<b>Heavy Duty:</b>		<b>Mixers</b>		Hot mills – Strip and sheet mills .....	3.0
Dredge, Inclined belt and screw .....	1.5	Drum .....	1.5	Reversing, blooming or slabbing mills .....	
Reciprocating .....	3.0	Concrete (continuous or intermittent) .....	1.75	Refer to TB Wood's	
<b>Cranes and Hoists</b>		Grizzly .....	2.0	Edging mills .....	
Main hoist – medium duty/mine haulage .....	2.5	<b>Oil Industry</b>		Refer to TB Wood's	
Main hoist – heavy duty .....	3.0	Chiller .....	1.25	Cooling beds .....	1.5
Long or cross travel/Slew or luff skip		Oil well pumping		Wire drawing/Slitters, steel mills only .....	1.75
hoist/slope .....	1.75	(<than 150% peak torque) .....	2.0	Drawbench/Furnace pusher/hot	
<b>Crushers</b> .....	2.5	<b>Paper Mills</b>		and cold saws/Ingot curs/Reelers/	
<b>Dredgers</b> .....	2.0	Bleacher .....	1.0	Straighteners .....	2.0
<b>Elevators</b>		Felt stretcher .....	1.25	Seamless tube mills piercer/	
Centrifugal and gravity discharge .....	1.25	Stock chest/stock pump – rotary/winder .....	1.5	Rod mills/mill tables/Manipulators/ Feed	
<b>Fans</b>		Bleacher and pulper/Calender/Couch/		rolls-blooming mills .....	3.0
Centrifugal .....	1.0	Dryer/Fourdrinier/ Press/Pulp grinder/		<b>Sugar Industry</b>	
Forced draft .....	1.5	Suction roll .....	1.75	Cane carrier and leveller .....	1.75
Induced draft with damper .....	1.5	Jordan/Stock pump-reciprocating .....	2.0	Cane knife and crusher .....	2.0
Mine/Cooling tower .....	2.0	Barking drum/Chipper .....	2.5	Mill stands Turbine driven-Helical	
Induced draught without control .....	2.0	<b>Plastic</b>		or Herringbone gears .....	1.5
<b>Food</b>		Calenders/Crushers/Extruders/Mixers .....	1.5	Electric drive or steam driven with	
Beet slicer .....	1.75	<b>Pulverizers</b>		all Helical or Herringbone or spur	
Cereal cooker .....	1.25	Roller/Hammer mill, light duty .....	1.5	gears with any prime mover .....	1.75
Dough mixer .....	1.75	Hog/Hummer mill, heavy duty .....	1.75	<b>Textiles</b>	
Meat grinder .....	1.75	<b>Pumps</b>		Batcher .....	1.25
Bottling, can filling .....	1.00	Centrifugal .....	1.0	Dyeing machinery .....	1.25
<b>Generators</b>		Descaling with accumulators/ Rotary gear,		Calender/Card machine/Dry can/Loom .....	1.5
Even load .....	1.0	Lobe and Vane .....	1.25	<b>Tobacco and Cigarette Machinery</b> .....	1.5
Hoist and Railway service .....	1.5	<b>Reciprocating</b>		<b>Water Waste Treatment</b>	
Welder load .....	2.0	1 cylinder, single or double acting .....	3.0	Aerators .....	1.5
<b>Kiln</b> .....	2.0	2 cylinder, single acting .....	2.0	Screw pumps .....	1.5
		2 cylinders, double acting .....	1.75	Screens .....	1.5
		3 cylinders or more .....	1.5	<b>Wind Turbines</b> .....	1.25
				<b>Wood Working Machinery</b>	
				Trimmers, haulage, barkers, planes, saws .....	2.0

The above service factors are for general guidance only and should be considered as a minimum. They are complimentary to customers specialist knowledge for their own equipment.

## Reciprocating Engines

**Table 1A**

Number of Cylinders	Service Factor
6 and over	0.5 + S.F. Table 1
4 or less	1.0 + S.F. Table 1
Less than 4	Refer to TB Wood's

For drives where the operation is near or actually passes through a major torsional natural frequency, a mass elastic analysis of the system is advised. When the Service Factor in Table 1 is greater than 2.0, consult your supplier or TB Wood's.

**Rating** – To determine the torque rating, calculate using the procedures given on page F4-6. Information may also be found on the nameplate of the motor, etc.

**Service Factor** – When selecting a coupling it is important to consider the characteristics of the drive and driven equipment. A figure known as the Service Factor has been calculated based on an average of a wide range of applications. This can be used as a guide in the selection process and is displayed in Table 1 on page F4-8.

**Size** – In making the decision from the following product groups which is most suited to the application, select a size equal to or higher than the rating calculated. Particular attention should be made to bore sizes, and guidance for this is in the Table related to Max Bore Sizes.

**Speed** – Ensure that the speed is compatible.

**Should full information not be supplied to TB Wood's at the time of ordering, it will be the responsibility of the customer to ensure that the coupling has been correctly selected.**

**As our policy is one of continual improvement, this specification is not to be regarded as binding in any way, and is subject to alteration without notice. Certified drawings are available on request.**

# Stock Bores

## Stock Grid Inch Hubs

BORE (IN.)	PRODUCT NO.	1020T	1030T	1040T	1050T	1060T	1070T	1080T	1090T	1100T	1110T	1120T	1130T	1140T
Solid-No bore	<b>RB</b>	X	X	X	X	X	X	X	X	X	X	X	X	X
1/2	<b>12</b>	X												
9/16	<b>9/16</b>	X												
5/8	<b>58</b>	X	X											
3/4	<b>34</b>	X	X	X	X									
7/8	<b>78</b>	X	X	X	X	X								
15/16	<b>15/16</b>	X	X	X	X									
1	<b>1</b>	X	X	X	X	X	X							
1-1/16	<b>1116</b>	X	X	X	X	X								
1-1/8	<b>118</b>	X	X	X	X	X	X							
1-3/16	<b>1316</b>		X	X										
1-1/4	<b>114</b>		X	X	X	X	X	X						
1-3/8	<b>138</b>		X	X	X	X	X	X	X					
1-7/16	<b>1716</b>			X	X	X	X	X	X					
1-1/2	<b>112</b>			X	X	X	X	X	X					
1-9/16	<b>1916</b>			X	X	X	X							
1-5/8	<b>158</b>			X	X	X	X	X	X					
1-11/16	<b>11116</b>				X		X	X						
1-3/4	<b>134</b>				X	X	X	X	X					
1-13/16	<b>11316</b>				X	X	X							
1-7/8	<b>178</b>				X	X	X	X	X					
1-15/16	<b>11516</b>					X	X	X	X					
2	<b>2</b>					X	X	X	X	X				
2-1/8	<b>218</b>					X	X	X	X	X				
2-3/16	<b>2316</b>						X	X						
2-1/4	<b>214</b>						X	X	X	X				
2-3/8	<b>238</b>					X	X	X	X	X				
2-7/16	<b>2716</b>						X	X	X	X				
2-1/2	<b>212</b>						X	X	X	X	X			
2-5/8	<b>258</b>							X	X	X				
2-11/16	<b>21116</b>							X						
2-3/4	<b>234</b>							X	X	X	X			
2-7/8	<b>278</b>							X	X	X	X			
2-15/16	<b>21516</b>							X	X	X				
3	<b>3</b>							X	X	X	X	X		
3-1/8	<b>318</b>								X	X				
3-1/4	<b>314</b>								X	X	X	X		
3-3/8	<b>338</b>								X	X	X			
3-7/16	<b>3716</b>								X	X	X			
3-1/2	<b>312</b>								X	X	X	X		
3-5/8	<b>358</b>								X	X	X			
3-3/4	<b>334</b>										X			
3-7/8	<b>378</b>									X	X	X		
3-15/16	<b>31516</b>									X	X	X		
4	<b>4</b>									X	X	X		
4-1/8	<b>418</b>										X			
4-3/16	<b>4316</b>										X			
4-7/16	<b>4716</b>										X			
4-1/2	<b>412</b>										X	X	X	
4-15/16	<b>41516</b>											X	X	
5	<b>5</b>											X		
5-7/16	<b>5716</b>												X	
Max Bore		1-1/8	1-3/8	1-5/8	1-7/8	2-1/8	2-1/2	3	3-1/2	4	4-1/2	5	6	7-1/4

Max bore is for hub w/ keyway for rectangular key

Example: Size 1020 coupling hub with 1-1/8" bore = 1020T118  
 Size 1040 coupling hub with NO bore - for rebore = 1040TRB

# Product Features and Options

Features	Form-Flex®						Torsiflex-i
	A-Series		G-Series				TFI
	AR, AP AX, AY, AA	A5, A6, A7	GP	G5	GR	GCH, GCF, HSH, FSH	
<b>Standard Bore Fit:</b>	Clearance		Interference				
<b>Set Screws:</b>	Standard		Optional				
<b>Puller Holes:</b>	Optional						Standard
<b>Standard Flex Disc:</b>	300 Series Stainless Steel <sup>(1)</sup>					Alloy Steel <sup>(2)</sup>	300 Series SS
<b>Balance Class:</b>	AGMA 7	N/A	AGMA 8	N/A	AGMA 8	N/A	AGMA 9
<b>Dynamic Balance:</b>	Optional	Per TBW Commercial Standard	Optional	Per TBW Commercial Standard	Optional	N/A	Optional

(1) Stainless Steel is standard. Alloy Steel is optional.

(2) Alloy Steel is standard. Stainless Steel is optional.

## Form-Flex® Disc Coupling Advantages

- Over 40 years experience in flexible disc couplings
- All metal Construction
- No Lubrication
- No Moving Parts
- Long Life
- High Torsional Stiffness
- Precise Positioning - Zero Backlash

## Applications

Flexible Disc couplings can be used in a wide variety of application from general industrial equipment to high speed precision machines. They are one of the most versatile coupling designs and can be customized to meet the demands of almost every application. Some of the applications in which Flexible Disc couplings can be used are:

- General Purpose & API610 Pumps
- Centrifugal & Screw Compressors
- Reciprocating Compressors
- Fans & Blowers
- Food Processing
- Machine Tools
- Cooling towers
- Printing Presses
- Engine & Electric Motor Driven Applications
- Power Generation

# Coupling Application Types Table

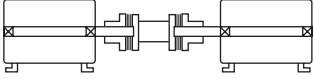
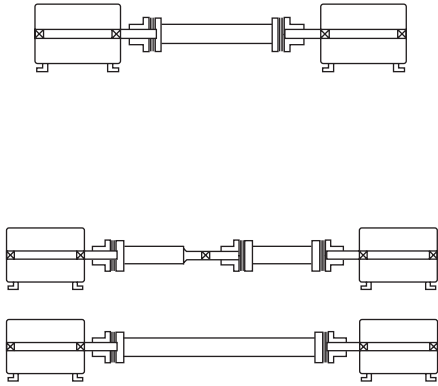
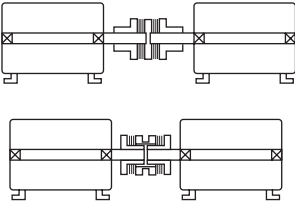
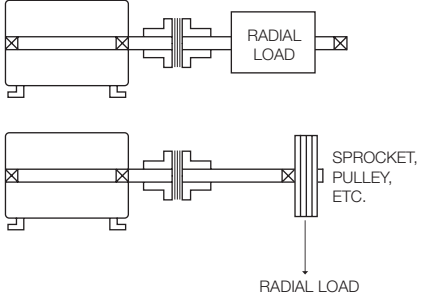
Coupling Type	Typical Applications	Series
<p><b>Spacer Couplings Double Flex</b></p>	<p>Spacer couplings are used to connect fully supported shafts with wider separations than can be reached with a close couple design. Spacer couplings allow room for installation and maintenance without moving the connected equipment. Shaft separations are generally in the range of 3 to 12 inches. These couplings accommodate angular, parallel and axial misalignment.</p>	 <p><b>AP, GP, TFI, GCF, GCH, FSH, HSH</b></p>
<p><b>Floating Shaft Coupling</b></p>	<p>Floating shaft couplings are spacer style couplings which are designed to connect widely separated shafts. The coupling spacers are fabricated. Both steel and TrueTube composite tubing options are available.</p> <p>Semi-floating shaft couplings are a special single flex version of the floating shaft coupling. These may be used alone for some applications or in combination with floating shaft couplings and pillow block bearings to span long distances.</p> <p>Composite floating shaft couplings should be considered as an alternative to multiple span applications with center bearings.</p>	 <p><b>A5, A5C, G5, B5C</b></p>
<p><b>Close Couple Double Flex</b></p>	<p>Close couple designs accommodate angular, parallel and axial misalignment types where two fully supported shafts are located very close together. Close shaft separations are generally in the range of 1/8 to 2 inches.</p>	 <p><b>AA, AX, AY</b></p>
<p><b>Single Flex</b></p>	<p>Single flexing couplings compensate for angular and axial misalignment only. Single couplings should only be used in a three bearing system with a self-aligning bearing as shown in the illustration. Single couplings may also be used in pairs to support a clutch, transducer or other system component. These arrangements are double flexing and must be used with two fully supported shafts as described below.</p>	 <p><b>AR, GR</b></p>

# Coupling Selection Process

1) Select correct Service Factor (S.F.) from the chart below.

2) Calculate HP/100 RPM or Design Torque (lb-in).

$$\text{HP/100 RPM} = \frac{\text{HP} \times \text{S.F.} \times 100}{\text{coupling RPM}}$$

OR

$$\text{Design Torque (lb-in)} = \frac{63025 \times \text{HP} \times \text{S.F.}}{\text{coupling RPM}}$$

OR

$$\text{Design Torque} = \text{Torque (lb-in)} \times \text{S.F.}$$

Calculate kW/100 RPM or Design Torque (Nm)

$$\text{kW/100RPM} = \frac{\text{kW} \times \text{S.F.} \times 100}{\text{coupling RPM}}$$

$$\text{Design Torque (Nm)} = \frac{9550 \times \text{kW} \times \text{S.F.}}{\text{coupling RPM}}$$

$$\text{Design Torque} = \text{Torque (Nm)} \times \text{S.F.}$$

3) Compare this to the HP/100 RPM (kW/100 RPM) column or the Rated Torque column.

4) Check other limiting factors such as max bores, minimum DBSE, max speed and overall dimensions.

Unit Conversions: HP x .746 = kW or kW x 1.34 = HP  
Nm x 8.851 = lb-in or lb-in x .113 = Nm

## SERVICE FACTOR TABLE

These service factors assume a smooth motor or turbine type driver. The adders listed for other driver types must be added to the service factor shown for the driven equipment.

Adders For Driver Type		Driven Equipment	S.F.	Driven Equipment	S.F.	Driven Equipment	S.F.
DRIVER	ADD	CONVEYORS-Uniform load (Cont.)		FANS		PAPER MILLS-(Cont.)	
TURBINE	0	Flight	1.25	Centrifugal	1.00	Couch	1.75
AC MOTORS		Oven	1.50	Cooling Tower	2.00	Cutters, Platers	2.00
With Soft Start	0	Screw	1.25	FEEDERS		Cylinders	1.75
NEMA A or B, IEC N	0	CONVEYORS-Non-Uniform Load		Apron	1.25	Dryers	1.75
NEMA C or D, IEC H	1	Apron	1.50	Belt	1.25	Felt Stretchers	1.25
DC MOTORS		Assembly	1.25	Disc	1.25	Felt Whipper	2.00
Shunt Type	0	Belt	1.25	Reciprocating	2.50	Presses	2.00
Series or Compound	1	Bucket	1.50	Screw	1.25	Reel	1.50
I/C ENGINES		Chain	1.50	FOOD INDUSTRY		Stock Chests	1.50
8 or More Cylinders	1	Flight	1.50	Cereal Cookers	1.25	Suction Roll	1.75
4-6 Cylinders	1.5	Oven	1.50	Dough Mixers	1.75	Washers and Thickeners	1.50
1-3 Cylinders	2	Reciprocating	2.50	Meat Grinders	1.75	Winders	1.50
<b>Driven Equipment</b>	<b>S.F.</b>	Screw	1.50	Slicers	1.75	PRINTING PRESSES	1.50
AGITATORS		Shaker	2.50	LUMBER INDUSTRY		PUMPS	
Pure Liquids	1.00	CRANES AND HOISTS		Barkers-Drum Type	2.00	Centrifugal	1.00
Liquids and Solids	1.25	Main Cranes	2.00	Edger Feeders	2.00	Reciprocating	
Liquids-Variable Density	1.25	Reversing	2.00	Live Rolls	2.00	Double Acting	2.00
BLOWERS		Skip Hoists	1.75	Log Haul	2.00	Single Acting 1-2 Cylinders	2.25
Centrifugal	1.00	Trolley Drive	1.75	Off Bearing Rolls	2.00	Single Acting 3+ Cylinders	1.75
Lobe	1.50	Bridge Drive	1.75	Planers	1.75	Rotary-Gear, Lobe, Vane	1.50
Vane	1.25	Slope	1.50	Slab Conveyors	1.50	TEXTILE INDUSTRY	
BRIQUETTER MACHINE	1.00	DREDGES		Sorting Table	1.50	Batchers	1.25
CAN FILLING MACHINE	1.00	Cable Reels	1.75	Trimmer Feed	1.75	Calenders	1.75
COMPRESSORS		Conveyors	1.50	MACHINE TOOLS		Card Machines	1.50
Centrifugal	1.25	Maneuvering Winches	1.75	Bending Roll	2.00	Cloth Finishing Machines	1.50
Lobe	1.50	Pumps	1.75	Plate Planer	1.50	Dry Cans	1.75
Reciprocating	C/F	Screen Drives	1.75	Spindle Drives	1.50	Dryers	1.50
CONVEYORS-Uniform Load		Stracers	1.75	Table/Axis Drives	1.25	Dyeing Machinery	1.25
Apron	1.25	Utility Winches	1.50	Tapping Machines	2.50	Looms	1.50
Assembly	1.00	ELEVATORS		PAPER MILLS		Mangles	1.25
Belt	1.00	Bucket	1.75	Beater & Pulper	1.75	Nappers	1.25
Bucket	1.25	Centrifugal Discharge	1.50	Bleacher	1.00	Soapers	1.25
Chain	1.25	Freight	2.00	Calendars	2.00	Spinners	1.50
		Gravity Discharge	1.50	Converting Machines	1.50	Tinter Frames	1.50









# Coupling Selection Guide

- 1) Consult factory for applications in shaded areas.
- 2) Torque ratings may vary by coupling series.
- 3) Use the 1.0 service factor column if a service factor was used in the HP/100 RPM calculation.

**Consult Altra Couplings Engineering**

**Not Recommended for these Applications**

Typical Application Conditions						
SMOOTH MOTOR OR TURBINE DRIVEN 	STEADY MOTOR OR TURBINE DRIVEN 	MODERATE MOTOR OR TURBINE DRIVEN 	MEDIUM MOTOR OR TURBINE DRIVEN 	HEAVY-HIGH TQ. MOTOR OR ENGINE DRIVEN 	EXTRA HEAVY ENGINE DRIVEN 	EXTREMELY HEAVY ENGINE DRIVEN 
SOFT START WITH STEADY LOAD	AVERAGE STARTING LOADS AND SLIGHT TORQUE VARIATIONS	ABOVE AVERAGE STARTING LOADS AND MODERATE LOAD VARIATIONS	HIGH STARTING TORQUES AND MEDIUM TO HEAVY LOAD VARIATIONS	MILD SHOCK LOADING ENGINES. DRIVING SMOOTH LOADS. EXTREME RELIABILITY	HEAVY SHOCK LOADING OR LIGHT REVERSING	EXTREME SHOCK LOADING. FREQUENT WIDE TORQUE VARIATIONS

Type/Size	Torque Rating				O.D. (in)	Service Factor						# of Bolts	
	HP / 100 RPM	Max Continuous (lb-in)	Peak Overload (lb-in)	Rated HP/100 RPM at Service Factor Shown									
				1.0		1.5	2.0	2.5	3.0	3.25	4.0		
Form-Flex® A-Series	05	0.48	300	600	2.65	0.48	0.32	0.24	0.19				4
	10	1.27	800	1,600	3.19	1.27	0.85	0.63	0.51				
	15	2.50	1,575	3,150	3.65	2.50	1.67	1.25	1.00				
	20	3.49	2,200	4,400	4.08	3.49	2.33	1.75	1.40				
	25	6.03	3,800	7,600	4.95	6.03	4.02	3.01	2.41				
	30	11.00	6,930	13,860	5.63	11.00	7.33	5.50	4.40				
Form-Flex® G-Series	35	18.00	11,340	22,680	6.63	17.99	12.00	9.00	7.20				6
	311	17.5	11,000	22,000	5.88	17.45	11.64	8.73	6.98	5.8	5.4		
	321	32.5	20,500	41,000	6.38	32.53	21.68	16.3	13.0	10.8	10		
	332	50.8	32,000	64,000	7.20	50.8	33.8	25	20	17	16		
	346	73.0	46,000	92,000	8.20	73.0	48.7	36	29	24	22		8
	380	127	80,000	160,000	9.36	127	85	63	51	42	39		
	340	63.5	40,000	80,000	8.38	63.5	42.3	32	25	21	20	16	
	412	190	120,000	240,000	11.00	190	127	95	76	63	59	48	
	419	301	190,000	380,000	12.50	301	201	151	121	100	93	75	
	424	476	300,000	600,000	15.00	476	317	238	190	159	146	119	
	444	690	435,000	870,000	16.38	690	460	345	276	230	212	173	
	456	889	560,000	1,120,000	18.00	889	592	444	355	296	273	222	
	483	1317	830,000	1,660,000	19.44	1317	878	658	527	439	405	329	
	511	1745	1,100,000	2,200,000	22.00	1745	1164	873	698	582	537	436	
520	3173	2,000,000	4,000,000	24.88	3173	2116	1587	1269	1058	976	793		
525	3967	2,500,000	5,000,000	26.75	3967	2644	1983	1587	1322	1221	992		
530	4760	3,000,000	6,000,000	28.00	4760	3173	2380	1904	1587	1465	1190		
540	6347	4,000,000	8,000,000	33.50	6347	4231	3173	2539	2116	1953	1587		
Torsiflex-i TFI	17	2.4	1,504	2,632	2.87	2.39	1.59	1.19	0.95	0.80	0.73		6
	27	3.8	2,390	4,183	3.35	3.79	2.53	1.90	1.52	1.26	1.17		
	38	5.3	3,363	5,885	4.21	5.34	3.56	2.67	2.13	1.78	1.64		
	140	19.7	12,391	21,684	5.00	19.66	13.1	9.83	7.86	6.6	6.0		
	260	36.5	23,031	40,304	6.06	36.54	24	18.3	14.6	12	11		
	400	56.2	35,404	61,957	6.93	56.2	37	28	22	19	17		
	750	105	66,383	116,170	7.99	105	70	53	42	35	32		8
	1310	184	115,948	202,909	9.49	184	123	92	74	61	57		
	1900	267	168,169	294,296	10.98	267	178	133	107	89	82		
	2500	351	221,275	387,231	11.65	351	234	176	140	117	108		
	3300	463	292,083	511,145	12.84	463	309	232	185	154	143		
	6000	843	531,060	929,355	15.55	843	562	421	337	281	259		
8500	1194	752,335	1,316,586	17.44	1194	796	597	477	398	367			
12000	1685	1,062,120	1,858,710	19.45	1685	1123	843	674	562	519			
Form-Flex® (HSH/FSH)	22	15.1	9,500	14,250	6.00	15.07	10.05	7.54	6.03	5.02	4.64	3.8	8
	26	25.4	16,000	24,000	6.87	25.39	16.9	12.7	10.2	8.5	7.8	6	
	31	38.1	24,000	36,000	8.12	38.08	25	19.0	15.2	13	12	10	
	35	69.8	44,000	66,000	9.12	69.8	47	35	28	23	21	17	
	37	95.2	60,000	90,000	10.06	95.2	63	48	38	32	29	24	
	42	116	73,000	109,500	11.00	116	77	58	46	39	36	29	
	45	157	99,000	148,500	11.44	157	105	79	63	52	48	39	
	50	203	128,000	192,000	13.00	203	135	102	81	68	62	51	
	55	300	189,000	283,500	15.00	300	200	150	120	100	92	75	
	60	414	261,000	391,500	16.00	414	276	207	166	138	127	104	
	70	658	415,000	622,500	18.50	658	439	329	263	219	203	165	
	75	846	533,000	799,500	20.00	846	564	423	338	282	260	211	
	80	1087	685,000	1,027,500	22.00	1087	725	543	435	362	334	272	
	85	1315	829,000	1,243,500	23.75	1315	877	658	526	438	405	329	
	92	1650	1,040,000	1,560,000	25.75	1650	1100	825	660	550	508	413	
92HT	2221	1,400,000	2,100,000	25.75	2221	1481	1111	889	740	683	555		

# Standard Bore Tolerances

## Imperial Standard Bore and Keyway Info

### Recommended Bore Tolerance for Imperial Shafts (Inches)

Nominal Shaft Range		Shaft Tol.	Interference Fit Bore Tol.	Clearance Fit Bore Tol.
Over	To (Incl.)			
.4375	1.5	+.0000 / -.0010	-.0005 / -.0010	+.0010 / -.0000
1.5	2		-.0010 / -.0020	+.0010 / -.0000
2	3		-.0010 / -.0020	+.0015 / -.0000
3	4		-.0015 / -.0030	
4	5		-.0020 / -.0035	
5	7		-.0025 / -.0040	
7	8		-.0030 / -.0050	N/A
8	9		-.0035 / -.0055	N/A
9	10		-.0040 / -.0060	N/A

Reference AGMA 9002-B04

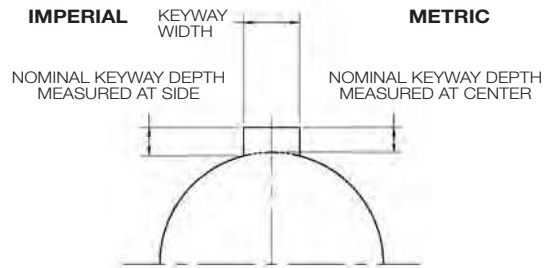

### Recommended Hub Keyway Dimensions (Inches)

Nominal Bore Range		Key Dims.		
Over	To (Incl.)	Width	Depth Square Key	Depth Reduced Key
0.312	0.438	0.094	0.047	-
0.438	0.562	0.125	0.063	0.047
0.562	0.875	0.188	0.094	0.062
0.875	1.250	0.25	0.125	0.094
1.250	1.375	0.312	0.156	0.125
1.375	1.750	0.375	0.188	0.125
1.750	2.250	0.500	0.250	0.188
2.250	2.750	0.625	0.313	0.219
2.750	3.250	0.750	0.375	0.250
3.250	3.750	0.875	0.438	0.313
3.750	4.500	1.000	0.500	0.375
4.500	5.500	1.250	0.625	0.438
5.500	6.500	1.500	0.750	0.500
6.500	7.500	1.750	0.875	0.750
7.500	9.000	2.000	1.000	0.750
9.000	11.000	2.500	1.250	0.875

Standard keyway fit is Commercial Class per AGMA 9002-B04

## Metric Standard Bore and Keyway Info

### Recommended Bore Tolerance for Metric Shafts (mm)

Nominal Shaft Range		Shaft Tol.	Shaft Des.	Clearance Fit		Clearance Fit	
Over	To (Incl.)			Bore Tol.	Bore Des.	Bore Tol.	Bore Des.
12	18	+.008 / -.003	j6	+.016 / +.034	F7	-.015 / -.004	M6
19	30			+.020 / +.041	F7	-.017 / -.004	M6
32	50	+.018 / +.002	k6	+.025 / +.050	F7	-.013 / +.003	K6
55	80			+.030 / +.060	F7	-.021 / +.009	K7
85	100	+.035 / +.013	m6	+.036 / +.071	F7	-.035 / +.000	M7
110	120					+.035 / +.013	-.059 / -.024
125	180	+.040 / +.015		+.043 / +.083	F7	-.068 / -.028	P7
190	200			+.046 / +.017	+.050 / +.096	F7	-.079 / -.033
210	225	-.109 / -.063					R7
230	250	-.113 / -.067					R7
260	280	+.052 / +.020		+.056 / +.108	F7	-.126 / -.074	R7

Reference AGMA 9112-A04

### Recommended Hub Keyway Dimensions (mm)

Nominal Bore Range		Nominal Key Size	Hub Keyway		
Over	To (Incl.)		Width	Depth	
				Nominal	Nominal
10	12	4X4	4	1.8	
12	17	5X5	5	2.3	
17	22	6X6	6	2.8	
22	30	8X7	8	3.3	
30	38	10X8	10	3.3	
38	44	12X8	12	3.3	
44	50	14X9	14	3.8	
50	58	16X10	16	4.3	
58	65	18X11	18	4.4	
65	75	20X12	20	4.9	
75	85	22X14	22	5.4	
85	95	25X15	25	5.4	
95	110	28X16	28	6.4	
110	130	32X18	32	7.4	
130	150	36X20	36	8.4	
150	170	40X22	40	9.4	
170	200	45X25	45	10.4	
200	230	50X28	50	11.4	
230	260	56X32	56	12.4	
260	290	63X32	63	12.4	

Standard metric keyway width tolerance per Js9

# Engineering Standards

## INDUSTRY STANDARDS REFERENCED

AGMA 9002-B04 - BORES AND KEYWAYS FOR FLEXIBLE COUPLINGS (INCH SERIES)  
AGMA 9112-A04 - BORES AND KEYWAYS FOR FLEXIBLE COUPLINGS(METRIC SERIES)  
AGMA 922-A96 - LOAD CLASSIFICATION AND SERVICE FACTORS FOR FLEXIBLE COUPLINGS  
API610 / ISO 13709 - CENTRIFUGAL PUMPS FOR PETROLEUM, PETROCHEMICAL AND NATURAL GAS INDUSTRY, 11th Edition - Torsiflex-i meets the requirements of API610, 11th Edition when supplied with interference fit bores.  
API671 / ISO 10441 - SPECIAL PURPOSE COUPLINGS FOR PETROLEUM, CHEMICAL AND GAS INDUSTRY SERVICES, 4th Edition  
NEMA MG1 14.38, MG1 20.81 AND MG1 21.82 - All Form-Flex® & Torsiflex-i flexible disc couplings meet these standards without the addition of a limited end float device

Certain tables and data in this catalog were extracted from the reference AGMA standards with the permission of the publisher, the American Gear Manufacturers Associations, 1901 North Meyer Drive, Arlington, VA 22209.

## DYNAMIC BALANCING RECOMMENDATIONS

Use this graph to determine the appropriate balance class based on coupling weight and operating speed. The balance classes listed on the graph are for equipment with average sensitivity to coupling unbalance. The user should determine how sensitive the equipment train is to coupling unbalance. Use one balance class higher if your system has higher than average sensitivity to unbalance. Use one balance class lower if your system has lower than average sensitivity to unbalance. Use this guide to check your coupling selection against the recommended balance class for your operating conditions.

The following factors should be considered when determining a machine's sensitivity to coupling unbalance.

- 1) Shaft End Deflection: Machines having flexible shaft extensions are relatively sensitive to coupling unbalance.
- 2) Bearing Load Due to Coupling Weight Relative to Total Bearing Load: Machines having lightly loaded bearings, bearings that are primarily loaded by the weight of the coupling or other overhung weight are relatively sensitive to coupling unbalance.
- 3) Bearing, Bearing Support and Foundation Flexibility: Machines or systems with flexible foundations for supports for the rotating elements are relatively sensitive to coupling unbalance.
- 4) System Natural Frequencies: Machines operating at or near natural frequencies are sensitive to coupling unbalance.
- 5) Machine Separation: System having widely separated machines are relatively sensitive to coupling unbalance.
- 6) Shaft Extension Relative to Bearing Span: Machines having a short bearing span relative to their shaft extensions are sensitive to static unbalance.

BALANCE CLASS SELECTION CHART

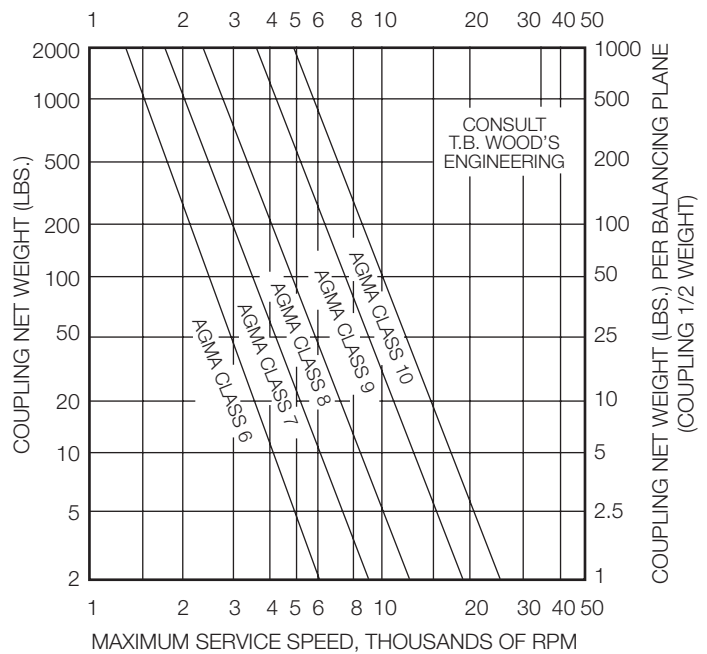

## HOW FLEXIBLE DISC COUPLINGS ACCOMMODATE MISALIGNMENT

Double flexing metal disc couplings may be used to accommodate angular, parallel and axial misalignment. Single flexing couplings may only be used to accommodate angular and axial misalignment. A metal disc type coupling uses a double hinge effect through two flexible discs and the spacer to compensate for parallel offset misalignment between shafts. Parallel misalignment imposes the same angular deflection (A) on each flex disc. Angular misalignment of either connected shaft, (B), creates additional angular deflections which are added to the angular offset due to parallel misalignment. The total misalignment angle, (C), at the flex disc is equal to the angular offset due to parallel misalignment (A) plus the angular offset due to angular misalignment (B). The maximum misalignment angle (C) should never exceed the rated misalignment capacity of the coupling type being used. Machinery equipment changes in actual operation and over the life of the equipment. We recommend that the machinery misalignment be set as close to zero as possible when a coupling is installed. We recommend keeping the measured misalignment below 25% of the rated misalignment capacity of the coupling type used when the machinery is installed and aligned. The remaining coupling misalignment capacity will then be available to accommodate additional misalignment caused by foundation shifts, vibrations, thermal growth or other causes.

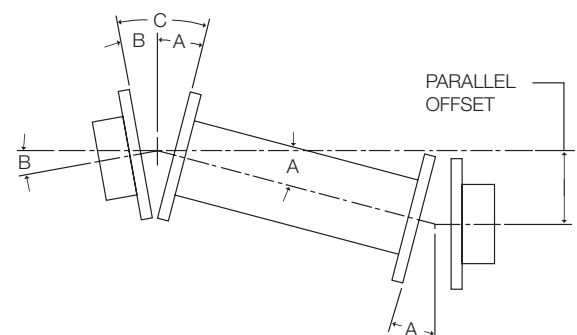

# Product Differentiation

Form-Flex® A - Series	Form-Flex® G - Series	Torsiflex-i TFI - Series
Higher bore capacity in low torque range	Higher Torque Density	Higher Torque Density and large bore capacity
1 ° Misalignment	.3 - .5 ° Misalignment	.3 - .5 ° Misalignment
Clearance Fit is standard	Interference Fit is standard	Interference Fit is standard
AGMA 7 balance class	AGMA 8 balance class	AGMA 9 balance class
Non-Unitized Flex Pack	Unitized Flex Pack	Factory assembled Transmission Unit
ATEX Group II/ Cat 3	ATEX Group II/ Cat 3	ATEX Group II/ Cat 2 Anti-Sparking design is standard
Low to Moderate Speeds	Low to Moderate Speeds	High to Moderate speeds

## DISC PACK DESIGN COMPARISON

**Form-Flex® G-Series  
Sizes 311-380**

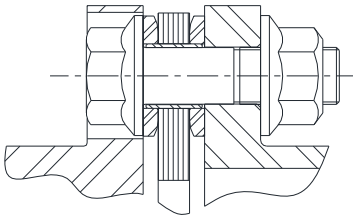

**UNITIZED**

- Disc pack force transferred to washer & hub interface
- Low bolt bending stress
- All torque transmitted through friction
- Higher torque capacity

**Form-Flex® G-Series  
Sizes 340 & 412-511**

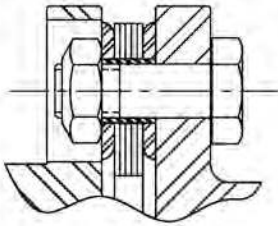

**Form-Flex® G-Series  
Sizes 517-540**

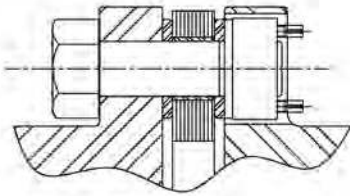

**Form-Flex®  
A-Series  
Sizes 5-35**

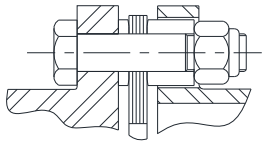

**Form-Flex®  
HSH/FSH**

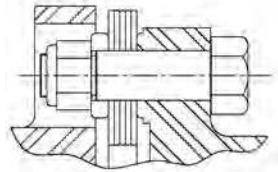

**NON-UNITIZED**

- Disc pack creates a bending moment on bolt
- High bolt bending stress
- Torque transmitted through shear and friction
- Lower torque capacity

## UNITIZED DISC DESIGNS

**Form-Flex®  
G-Series, Sizes 311-380  
(excluding 340)**

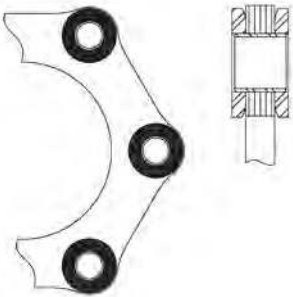

**Form-Flex®  
G-Series, Sizes 340 & 412-540**

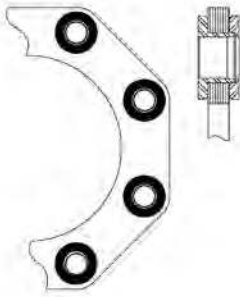

## NON-UNITIZED DISC DESIGNS

**Form-Flex®  
A-Series sizes 5-35**

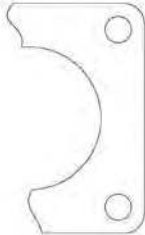

**Torsiflex-i  
Sizes 27-1310**

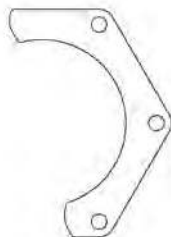

**Torsiflex-i  
Sizes 1900-1200**

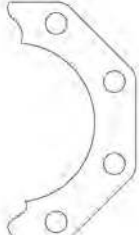

**Form-Flex®  
HSH/FSH**



# Spacer Couplings

---

## PRODUCT DESCRIPTION

- Designed for moderate to higher speed applications
- Construction includes:
  - Two fully machined steel hubs
  - One fully machined steel spool spacer
  - Standard hardware and stainless steel disc packs
- Form-Flex® A-Series designs use non-unitized disc packs
- Form-Flex® G-Series designs use unitized disc packs
- Torsiflex-i designs use a drop out transmission unit with non-unitized disc packs
- Custom length spacer up to max DBSE
- Balancing and other modifications to suit your special system requirements
- Can be bored for any shaft configuration (see page 38 & 39 for hub design options)



## TYPICAL APPLICATIONS

- Pumps
- Centrifugal and Screw Compressors
- Fans and Blowers
- Mixers
- Turbo Compressors

## SPECIAL APPLICATIONS

- Test Stands
- Machine Tools / Positioning Systems
- Electrical Insulation

# Spacer Coupling AP Series - Form-Flex®

## Double Flex Spacer

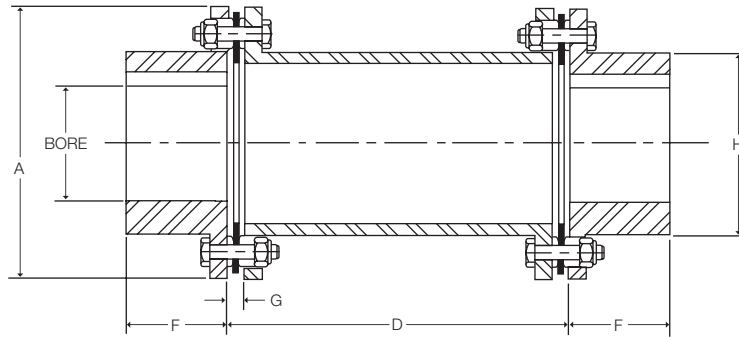

Size	Max Bore				Dimensions (in)								
	AJ		AZ		A	B		D DBSE		F	G	H	J
	(in)	(mm)	(in)	(mm)		Min	Max	Min	Max				
5	0.875	22	1.19	30	2.65	3.72	6.94	1.72	4.94	1.00	0.24	1.30	0.54
10	1.250	33	1.63	43	3.19	4.06	7.00	2.06	5.00	1.00	0.27	1.80	0.56
15	1.375	36	1.75	48	3.65	4.67	8.89	2.41	6.63	1.13	0.32	2.00	0.88
20	1.688	46	2.13	58	4.08	5.02	9.27	2.38	6.63	1.32	0.34	2.40	0.79
25	2.000	53	2.56	68	4.95	6.16	13.12	2.92	9.88	1.62	0.45	2.80	1.00
30	2.380	63	2.88	79	5.63	7.57	13.70	3.81	9.94	1.88	0.47	3.30	1.14
35	2.938	80	3.75	101	6.63	8.81	17.56	4.31	13.06	2.25	0.55	4.15	0.97

Dimensions are shown for standard AJ hubs unless otherwise specified.

Size	HP/100 RPM	Rated Torque (lb-in)	Peak O/L Torque (lb-in)	AGMA 7 Max RPM	Weight (lbs) (1)		WR <sup>2</sup> (lb-in <sup>2</sup> ) (1)		Misalignment Capacity	
					at D Min	Add Per Inch of D	at D Min	Add Per Inch of D	Axial (+/-in)	Angular (Degrees/Disc Pack)
5	0.48	300	600	8,500	2.32	0.14	1.87	0.05	0.015	1°
10	1.27	800	1,600	7,500	3.62	0.22	4.48	0.11	0.020	
15	2.5	1,575	3,150	6,700	5.44	0.26	8.86	0.19	0.021	
20	3.49	2,200	4,400	6,200	6.96	0.32	13.8	0.34	0.027	
25	6.03	3,800	7,600	5,500	12.7	0.41	38.8	0.62	0.030	
30	11	6,930	13,860	5,000	19	0.46	77.7	0.92	0.032	
35	18	11,340	22,680	4,400	27.6	0.63	156	2.29	0.042	

1) Weight and WR<sup>2</sup> values shown are for AJ hubs at max inch bore and spacer length at D Min

### STANDARD MATERIALS (CLASS A)

HUBS - CARBON STEEL

SPACER - CARBON STEEL

HARDWARE - ALLOY STEEL

DISC PACK - STAINLESS STEEL

### ORDERING

AP SERIES COUPLINGS ARE SOLD AS COMPONENTS

COUPLINGS CONSIST OF:

2 - HUBS - Example (AJ25A x 1-3/4")

1 - SPACER SUB-ASSEMBLY - Example for DBSE = 5.00"  
(AP25A500)

### MATERIAL / FINISH OPTIONS

CLASS A - Steel hubs and spacer, alloy steel hardware, 300 series stainless steel disc pack

CLASS B - Zinc plated steel hubs, and spacer, alloy steel hardware, 300 series stainless steel disc pack

CLASS C - Zinc plated steel hubs, and spacer, stainless steel hardware, 300 series stainless steel disc pack

CLASS E - 300 series stainless steel hubs and spacer, stainless steel hardware, 300 series stainless steel disc pack

(Only available for sizes 15 thru 35)



# Spacer Coupling GP Series - Form-Flex®

## Double Flex Spacer



Size	Torque Rating			Max Speed (RPM)		Weight (lbs) (1)		WR <sup>2</sup> (lb-in <sup>2</sup> ) (1)		Misalignment Capacity	
	HP / 100 (RPM)	Max Continuous (lb-in)	Peak Overload (lb-in)	AGMA 8	ABS. Max	at D Min	Add Per Inch of D	at D Min	Add Per Inch of D	Axial (+/- in)	Angular (Degrees/Disc Pack)
311	17	11,000	22,000	5,400	13,000	16.20	0.62	66.70	2.09	0.028	0.5°
321	33	20,500	41,000	4,900	12,000	25.75	0.66	123.01	2.54	0.029	
332	51	32,000	64,000	4,400	11,500	40.27	0.94	242.39	4.27	0.030	
346	73	46,000	92,000	4,100	9,000	54.42	1.03	429.27	6.94	0.050	
380	127	80,000	160,000	3,800	7,000	79.30	1.20	792.67	8.75	0.080	0.33°
412	190	120,000	240,000	3,500	6,000	110.1	1.45	1607.6	13.29	0.080	
419	301	190,000	380,000	3,000	5,000	197.8	2.32	3660.0	27.92	0.100	
424	476	300,000	600,000	2,750	5,000	287.6	3.08	8127.6	62.49	0.100	
444	690	435,000	870,000	2,500	4,000	413.3	3.38	13587	87.03	0.110	
456	1015	640,000	1,280,000	2,350	3,500	539	4.73	21896	133.5	0.120	
483	1317	830,000	1,660,000	2,200	3,500	727	5.36	33653	195.1	0.130	
511	1904	1,200,000	2,400,000	2,050	3,000	978	6.75	60082	310.3	0.140	
520	3173	2,000,000	4,000,000	1,750	2,500	1752	10.14	114979	586.5	0.180	
525	3967	2,500,000	5,000,000	1,700	2,500	2113	11.07	185975	762.5	0.200	
530	4760	3,000,000	6,000,000	1,600	2,500	2533	15.43	243383	1160.9	0.200	
540	6347	4,000,000	8,000,000	1,450	2,000	3831	19.23	557906	2247.7	0.240	

1) Weight and WR<sup>2</sup> values shown are for standard hubs at max inch bore and spacer length at D Min

### STANDARD MATERIALS

HUBS - CARBON STEEL

SPACER - CARBON STEEL

HARDWARE - ALLOY STEEL

DISC PACK - STAINLESS STEEL

### MATERIAL / FINISH OPTIONS

DISC PACK - ALLOY STEEL (For cost reduction, available for sizes 412 to 540)

ZINC ELECTRO PLATING

ZINC PHOSPHATE COATING

ALLOY STEEL HUBS



# Spacer Coupling GP Series - Form-Flex®

## Double Flex Spacer

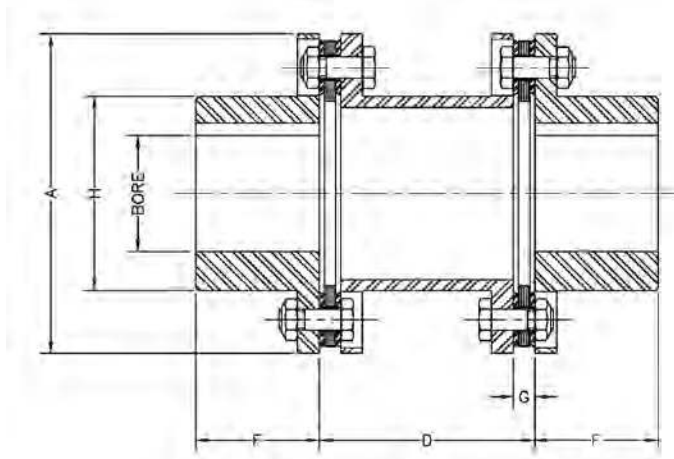

Size	Max Bore						Common Coupling Dimensions (in)								
	Standard Hub			Oversized/Large Hub			A	B		D DBSE		F	G	H	
	Square Key (in)	Rect. Key (in)	Rect. Key (mm)	Square Key (in)	Rect. Key (in)	Rect. Key (mm)		Min	Max	Min	Max			Std Hub	O/S Hub
311	2.813	3.063	78	3.125	3.313	86	5.88	8.06	17.75	3.06	12.75	2.50	0.40	3.91	4.30
321	3.000	3.250	83	3.250	3.438	90	6.38	10.13	19.06	4.13	13.06	3.00	0.55	4.25	4.57
332	3.188	3.313	87	3.438	3.688	95	7.20	11.00	19.19	5.00	13.19	3.00	0.61	4.50	4.95
346	3.750	4.000	107	4.250	4.500	117	8.20	11.00	25.19	5.00	19.19	3.00	0.62	5.42	5.95
380	3.750	4.000	105	4.250	4.500	118	9.36	15.00	28.00	6.75	19.75	4.13	0.89	5.65	6.30
412	4.500	4.500	120	4.750	5.125	135	11.00	14.19	27.94	5.69	19.44	4.25	0.75	6.51	7.20
419	4.500	4.875	130	5.500	5.625	150	12.50	17.69	29.94	7.69	19.94	5.00	0.98	7.32	8.07
424	6.880	6.625	190				15.00	20.19	32.44	7.69	19.94	6.25	0.98	9.57	
444	7.000	7.375	200				16.38	22.75	34.13	8.75	20.13	7.00	1.09	10.52	
456	8.000	8.000	220				18.00	24.31	35.13	9.81	20.63	7.25	1.32	11.63	
483	8.250	8.875	234				19.44	27.69	37.75	10.69	20.75	8.50	1.39	12.56	
511	10.000	10.125	280				22.00	29.69	39.06	11.69	21.06	9.00	1.56	14.50	
520	10.375	11.000	297				24.88	38.50	45.50	14.75	21.75	11.88	1.89	15.96	
525	11.000	12.000	322				26.75	39.38	45.88	15.38	21.88	12.00	1.95	17.35	
530	11.500	12.750	338				28.00	41.88	47.75	16.38	22.25	12.75	2.14	18.35	
540	15.750	17.000	448				33.50	49.00	54.13	19.00	24.13	15.00	2.58	22.63	

### ORDERING

GP SERIES COUPLINGS ARE SOLD AS COMPLETE ASSEMBLIES  
 PLEASE SPECIFY BORE SIZES, DISC PACK MATERIAL AND DBSE.  
 A COUPLING WILL BE CONFIGURED TO MEET YOUR SPECIFICATIONS.

# Pump Spacer Coupling TFI Series - Torsiflex-i

## API610/ISO13709 | Double Flex Spacer

### Torsiflex-i Disc Couplings Specifically designed for the process pump and general industrial markets.

The TFI coupling is specifically designed for the process pump and general industrial applications. It is comprised of two fully machined steel hubs, and a factory assembled drop out transmission unit. Standard spacer lengths are stock or it can be ordered for any custom spacing. This coupling is suitable for moderate to high speed operation on a wide range of general purpose motor and turbine driven equipment, including pumps, compressors and fans.



#### Advantages

- Standard coupling is fully compliant with the requirements of API610/ISO13709 & ISO14691
- Max bores matched to NEMA motor shafts, resulting in up to 60% weight savings per application
- Smaller diameter and lower weight per HP provide better inherent balance
- Plug-in spacer design allows installation and removal without disturbing the hubs
- Robust disc pack design allows for greater torque load in a smaller coupling, resulting in lower weight
- Large bolts for high clamp load, increasing frictional torque load, and reduced bolt bending stress
- ATEX compliance is standard — ExII 2GDc135degC(T4)
- Built-in Anti-Flail Feature
- Large hubs available on first three sizes
- Compliance with API 671 / ISO 10441 is available

#### Standard Materials

Hubs - Carbon Steel  
Adapters - Carbon Steel  
Spacer - Carbon Steel  
Disc Pack - Stainless Steel  
Hardware - Alloy Steel  
O/L Washers - High Strength  
“Non-Sparking” Material

#### Standard Finish

Zinc phosphate coating on hubs, spacers and adapters.

#### Features

- Torsiflex-i couplings consist of 2 hubs and a factory assembled transmission unit. Installation involves fitting the hubs to the machinery shaft ends, introducing the transmission unit, then securing with the attachment screws
- MAXIMUM SPEEDS shown are for standard materials. When higher speeds are required please consult TB Woods Engineering.
- AGMA 9 BALANCE CLASS is met when hubs are bored for interference fit.
- PEAK TORQUE of 1.75 and MOMENTARY TORQUE of 2.7 times the stated ratings are accepted
- SPARK FREE overload protection is provided as a standard feature on all Torsiflex-i couplings, making them suitable for GAS ZONE environments
- STANDARD COUPLINGS are designed for general purpose applications and are suitable for the majority of process pump, fan, and compressors applications
- SPECIAL COUPLING versions available include:
  - Torque overload protection
  - Limited end float
  - Electrical Insulation
  - Bolted adapters suitable for high cyclic torques

#### Material / Finish Options

Disc Pack - Inconel  
Zinc Electro Plating  
Alloy Steel Hubs  
Welded Tube Spacer for Longer Spans

# Pump Spacer Coupling TFI Series - Torsiflex-i

## API610/ISO13709 | Double Flex Spacer

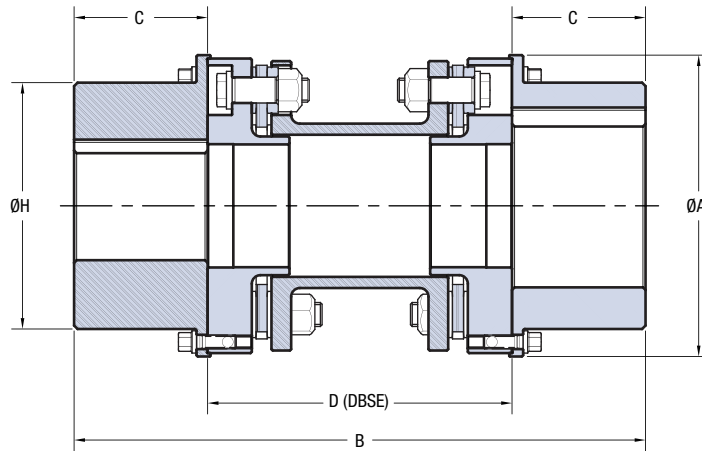

Size	Coupling Dimensions (in)					Max Bore				Stock Spacer Length (in)							
	A	B	C	H	Min DBSE (1)	Square Key		Reduced Key		3.50	4.38	5.00	5.50	7.00	7.50	8.00	9.00
						Standard Hub (in)	Large Hub (in)	Standard Hub (in / [mm])	Large Hub (in / [mm])								
17	2.87	5.67	1.46	2.047*	2.76	1.50	2.00	1.63 [40]	2.00 [52]	S	S	S	S	S	O	O	O
27	3.35	5.91	1.57	2.362*	2.76	1.75	2.25	1.81 [47]	2.25 [57]	S	S	S	S	S	O	O	O
38	4.21	6.30	1.77	2.992*	2.76	2.25	3.00	2.38 [61]	3.00 [76]	S	S	S	S	S	O	O	O
140	5.00	9.84	2.95	3.98	3.94	2.94	-	3.19 [81]	-		S	S	S	S	O	O	O
260	6.06	11.42	3.35	4.76	4.72	3.50	-	3.75 [97]	-			S	S	S	O	O	O
400	6.93	13.78	4.13	5.67	5.51	4.25	-	4.50 [117]	-					S	S	S	O
750	7.99	16.14	4.72	6.46	6.69	4.63	-	5.00 [132]	-					S	S	S	O
1310	9.49	19.29	5.71	7.76	7.87	5.63	-	6.13 [162]	-							S	S
1900	10.98	19.69	5.91	9.17	7.87	6.75	-	7.00 [192]	-							S	S
2500	11.65	21.57	6.46	9.45	8.66	6.88	-	7.13 [197]	-								S
3300	12.84	23.78	7.17	10.63	9.45	7.63	-	8.25 [220]	-								
6000	15.55	28.35	9.06	12.68	10.24	9.00	-	9.88 [265]	-								
8500	17.44	33.07	10.24	14.37	12.60	10.63	-	11.25 [302]	-								
12000	19.45	36.38	11.50	16.02	13.39	11.50	-	12.75 [337]	-								

\* For Large Hub H = A

- (1) The inclusion of additional features such as packing rings, shims and/or electrical insulation will increase the minimum DBSE (Distance Between Shaft Ends)  
 (2) S = Stocked length ; O = Optional length

Size	Torque Rating		Max Speed RPM	Weight Transmission Unit (lb)		Weight Unbored Hub (lb)		Angular Misalignment	Axial Deflection (in)
	HP / 100 RPM	(lb-in)		Mass @ Min DBSE	Extra Per (inch)	Standard	Large		
17	2.38	1,505	25,000	1.3	0.04	1.54	2.64	.5°	0.010
27	3.79	2,390	20,000	3.0	0.17	2.20	3.80		0.019
38	5.34	3,363	16,500	4.3	0.25	4.01	6.75		0.019
140	19.7	12,391	12,000	10.1	0.39	10.8	-		0.019
260	36.5	23,013	10,000	17.2	0.57	17.6	-		0.024
400	56.2	35,404	8,500	28.4	0.80	30.4	-		0.055
750	105	66,383	7,500	46.7	1.26	46.1	-		0.071
1310	184	115,948	6,500	80.7	1.49	80.2	-	0.087	
1900	267	168,169	5,600	100	1.84	109	-	.33°	0.059
2500	351	221,275	5,200	132	2.24	133	-		0.067
3300	463	292,083	4,900	179	2.73	186	-		0.071
6000	843	531,060	4,000	273	4.10	333	-		0.094
8500	1194	752,335	3,600	439	5.39	485	-		0.11
12000	1685	1,062,120	3,000	569	6.64	686	-		0.118

(3) For Finish Bore Hub weight = Weight Unbored hub - .222 \* Hub Length \* Bore Dia.^2

### ORDERING

TF SERIES COUPLINGS ARE SOLD AS COMPONENTS

COUPLINGS CONSIST OF:

2 - HUBS - Example (TF0038 x 2.00 mm)

1 - TRANSMISSION UNIT - Example for DBSE = 5.00" (TF0038SA500MM)

# Pump Spacer Coupling TFI Series w/ Torsi-Lock - Torsiflex-i

## API610/ISO13709 | Double Flex Spacer

- All Torsi-Lock devices must be sized to transmit the actual application Peak Torque. The data table shows a comparison of the Torsi-Lock torque transmissibility to the coupling Peak Torque Rating as a reference. The table below does not show all possible Torsi-Lock sizes and ranges. For any Torsi-Lock requirement beyond those detailed here, please consult TB Woods Engineering (see the catalog back cover for contact information).



- To determine the actual transmissible torque, as well as the actual combined hub plus Torsi-Lock device weight, from the data table, linearly interpolate between the range of values given for min and max shaft diameter. See the example interpolation calculation to the right.

- The data table is applicable to keyless shaft applications only. For keyed shaft applications, either:
  - Use a half key in the shaft and deduct the transmissible torque value of the Torsi-Lock by 10%
  - Use a full height key and the overkey dimension as the Shaft Size (dw) to determine the correct Torsi-Lock size.

Torsi-Lock Size				20	22	24	30	36	40	44	48	50	55	62	68	75	80	90	100							
Shaft Size Range	DW	Min (over)	in	0.630	0.709	0.787	0.827	1.024	1.220	1.339	1.417	1.575	1.654	1.890	2.047	2.362	2.559	2.756	2.953							
			mm	16	18	20	21	26	31	34	36	40	42	48	52	60	65	70	75							
		Max (incl)	in	0.709	0.787	0.827	1.024	1.220	1.339	1.417	1.575	1.654	1.890	2.047	2.362	2.559	2.756	2.953	3.150							
			mm	18	20	21	26	31	34	36	40	42	48	52	60	65	70	75	80							
Transmissible Torque (x1000)		TMin	lb-in	1.15	1.50	1.86	1.71	3.45	4.96	6.28	6.46	9.29	10.3	15.5	17.7	22.1	28.3	42.0	61.1							
		TMax	lb-in	1.59	2.04	2.21	3.36	5.58	7.08	7.61	9.82	12.2	16.6	19.9	27.9	35.0	40.7	64.2	79.7							
Torsi-Lock Device Dims	O.A.L.	L1	in	0.89	0.89	0.91	0.98	1.07	1.11	1.18	1.18	1.26	1.36	1.38	1.38	1.50	1.50	1.75	1.95							
	O.D.	Ht	in	1.89	1.89	1.97	2.36	2.83	2.95	3.15	3.15	3.54	3.94	4.33	4.53	5.43	5.71	6.10	6.69							
	Weight	Wt	lb	0.44	0.44	0.44	0.66	1.10	1.10	1.32	1.21	1.76	2.43	2.87	3.09	5.29	5.51	7.28	10.4							
Coupling Size	TFI0027			1.48	1.47	1.46	1.77	2.24	2.19	2.44	2.40	2.87	3.69													
	TFI0038			1.44	1.43	1.44	1.64	2.07	2.08	2.36	2.21	2.76	3.33													
	TFI0140			1.47	1.47	1.49	1.57	1.65	1.69	1.76	1.76	1.84	1.94													
	TFI0260								3.79	4.04	3.99	4.46	5.29	5.76	6.08	8.23	8.40	10.8	14.8							
	TFI0400								3.67	3.95	3.80	4.35	4.92	5.48	5.47	7.78	7.91	10.2	14.1							
	TFI0750								1.69	1.76	1.76	1.84	1.94	1.96	1.96	2.08	2.08	2.33	2.53							
	TFI1310																	6.29	6.74	7.55	7.99	8.28	10.4	10.5	12.9	16.8
	TFI1900																									
	TFI2500																									
	TFI3300																									
	TFI6000																									
	TFI8500																									
	TFI12000																									

**Example (Coupling Size 1310):**

90	100	110	115	125	140	155	165	175	185	195
25.4	29.2	33.1	33.5	33.2	38.4	41.0	48.9	54.7	63.0	79.3
24.7	28.4	32.1	31.4	30.8	33.1	36.4	47.1	50.8	58.8	74.3
2.80	2.99	3.29	3.45	3.35	3.35	3.35	3.80	3.80	3.80	4.19

Transmits less than Peak Starting Torque Rating of the Coupling. Therefore the actual Transmissible Torque must be compared against the Application Peak Torque.

Transmits more than Peak Starting Torque Rating of the Coupling.

# Pump Spacer Coupling TFI Series w/ Torsi-Lock - Torsiflex-i

## API610/ISO13709 | Double Flex Spacer

### Example Interpolation Calculation

To interpolate Torsi-Lock table data for a TF 0260 with a size 115 Torsi-Lock for a bore of 3.625":

Y	Z	3.346	dw MIN (Min. Bore)	Target Weight $w = w1 + \frac{Z}{Y} (X)$ $W = 21.3 + \frac{(3.625 - 3.346)}{(3.74 - 3.346)} (21.3 - 19.3)$ $W = 19.9$ (lbs)
		3.625	B (Target Bore)	
	3.740	dw MAX (Max. Bore)		
X		21.3	w1 (Wt. @ dw MIN)	Where: Z = B - dw MIN Y = dw MAX - dw MIN X = w2 - w1
		W	(Target Wt.)	
		19.3	w2 (Wt. @ dw MAX)	

Note that the same method can be used to determine actual Torsiloc transmissible torque ratings for bores that are in between the min and max.

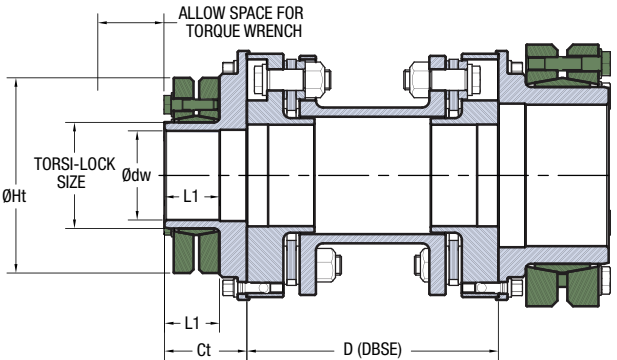

110	115	125	140	155	165	175	185	195	200	220	240	260	280	300	320	340	350	360	380	390
3.150	3.346	3.740	4.134	4.921	5.512	5.709	6.102	6.496	6.890	7.283	7.874	8.465	9.252	9.843	10.630	11.417	12.008	12.205	12.598	12.992
80	85	95	105	120	140	145	155	165	175	185	200	215	235	250	270	290	305	310	320	330
3.346	3.740	4.134	4.921	5.512	5.709	6.102	6.496	6.890	7.283	7.874	8.465	9.252	9.843	10.630	11.417	12.008	12.205	12.598	12.992	13.780
85	95	105	125	140	145	155	165	175	185	200	215	235	250	270	290	305	310	320	330	350
63.7	81.4	93.4	124	99	283	345	412	558	655	733	1,000	1,204	1,513	1,885	2,301	2,655	3,292	3,186	3,850	4,470
95.6	133	122	181	257	341	407	478	642	748	929	1,190	1,478	1,841	2,257	2,664	2,983	3,540	3,673	4,133	5,098
2.24	2.40	2.31	2.31	2.31	2.76	2.76	2.76	3.15	3.15	3.71	3.71	4.03	4.50	4.50	4.58	4.58	5.31	5.31	5.87	5.87
7.28	7.28	7.28	8.66	9.65	10.24	10.83	11.61	12.40	12.99	13.58	14.57	15.55	16.73	18.11	19.49	21.06	21.46	21.85	23.03	23.43
13.0	13.2	13.2	17.6	22.1	30.9	35.3	44.1	59.5	66.2	77.2	97.0	106	132	165	185	221	265	276	331	344
20.7	21.3																			
19.9	19.3																			
3.01	3.16																			
22.4	23.0	22.8	28.2																	
21.6	21.0	20.7	23.3																	
3.01	3.16	3.07	3.07																	
26.0	26.5	26.2	31.6	34.4																
25.1	24.4	24.0	26.5	30.0																
3.13	3.28	3.19	3.19	3.19																
33.1	33.5	33.2	38.4	41.0	48.9	54.7	63.0	79.3												
32.1	31.4	30.8	33.1	36.4	47.1	50.8	58.8	74.3												
3.29	3.45	3.35	3.35	3.35	3.80	3.80	3.80	4.19												
41.5	42.0	41.6	46.8	49.2	57.1	62.8	71.0	87.2	91.0	109										
40.6	39.8	39.2	41.3	44.5	55.1	58.8	66.7	82.2	85.7	98.9										
3.37	3.52	3.43	3.43	3.43	3.88	3.88	3.88	4.27	4.27	4.84										
	50.0	49.4	54.5	56.7	64.3	69.9	78.0	94.0	97.5	115	137									
	47.7	46.9	48.8	51.7	62.3	65.7	7.5	88.8	92.0	105	126									
	3.70	3.60	3.60	3.60	4.05	4.05	4.05	4.44	4.44	5.01	5.01									
			62.0	64.2	71.7	77.4	85.4	101	105	122	144	157								
			56.2	59.2	69.7	73.2	80.9	96.2	99.5	112	133	141								
			3.60	3.60	4.05	4.05	4.05	4.44	4.44	5.01	5.01	5.32								
				87.6	95.0	101	108	124	128	148	166	179	207	244	262					
				82.5	93.0	96.3	104	119	122	135	155	162	192	222	239					
				3.75	4.19	4.19	4.19	4.59	4.59	5.15	5.15	5.47	5.94	5.94	6.02					
						132	140	155	158	175	196	208	236	271	289	321	364	381		
						127	135	150	152	164	184	191	220	249	265	302	357	366		
						4.43	4.43	4.82	4.82	5.39	5.39	5.70	6.17	6.17	6.25	6.25	6.99	6.99		
								191	193	210	231	243	270	305	322	353	396	413	487	499
								185	187	199	219	225	254	282	297	334	389	397	470	463
								4.98	4.98	5.55	5.55	5.86	6.33	6.33	6.41	6.41	7.15	7.15	7.70	7.70

79.3 — Combined weight of the hub and Torsi-Lock device at the MIN shaft diameter.

74.4 — Combined weight of the hub and Torsi-Lock device at the MAX shaft diameter.

4.19 — Ct: Overall hub length thru bore (not including pilot lip)



# Floating Shaft Couplings

---

## PRODUCT DESCRIPTION

- Used for coupling spans that are greater than max catalog length for fully machined spacer designs
- Designed for moderate speed applications
- Construction includes:
  - Two fully machined steel hubs
  - One dynamically balanced welded or composite tube spacer
  - Standard hardware and stainless steel disc packs
- Form-Flex® A-Series designs use non-unitized disc packs
- Form-Flex® G-Series designs use unitized disc packs
- Spacers are configured for any custom length up to D-max shown per operating speed
- Can be bored for any shaft configuration (see page 38 & 39 for hub design options)

## TYPICAL APPLICATIONS

- Fans
- Turbo Compressors
- Vertical Pumping
- Cooling Tower
- Printing Press
- Paper Machines

## SPECIAL APPLICATIONS

- Mine Ventilation
- Dynamometers
- Test Stands
- Dredging Equipment
- Lift Tables

## DESIGN VARIATIONS

- A5/G5 - Welded Steel Tube
- A6/G6 - Welded Steel Tube - Vertical
- A7/G7 - Welded Steel Tube - Semi-Floating Spacer
- A5C/G5C - Composite Tube
- A6C/G6C - Composite Tube - Vertical
- A7C/G7C - Composite Tube - Semi-Floating

Large tube designs are available for speeds greater than catalog limits or for torsional tuning. Consult TB Wood's engineering for more info.



# Floating Shaft Spacer Coupling A5 Series - Form-Flex®

## Double Flex Floating Shaft

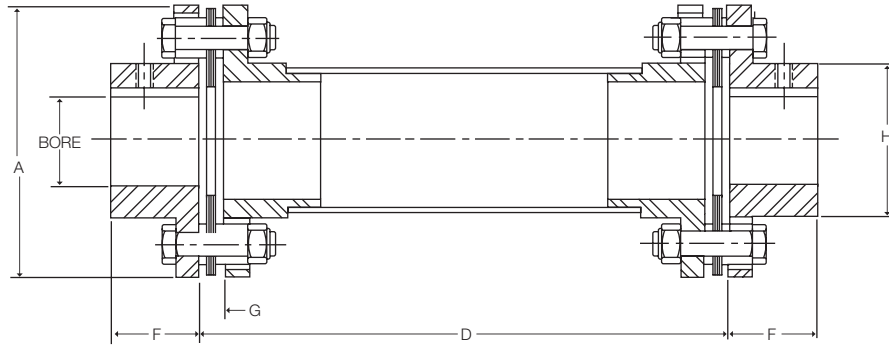

Size	Max Bore				Dimensions (in)					Max D (in) for RPM Shown					
	AJ		AZ		A	D Min	F	G	H	1800	1500	1200	900	750	600
	(in)	(mm)	(in)	(mm)											
5	0.875	22	1.19	30	2.65	4.94	1.00	0.24	1.30	51	56	62	71	78	87
10	1.250	33	1.63	43	3.19	5.00	1.00	0.27	1.80	62	69	76	88	96	107
15	1.375	36	1.75	48	3.65	6.63	1.13	0.32	2.00	64	71	79	91	99	111
20	1.688	46	2.13	58	4.08	6.63	1.32	0.34	2.40	73	81	90	103	113	126
25	2.000	53	2.56	68	4.95	9.88	1.62	0.45	2.80	79	87	97	112	122	137
30	2.380	63	2.88	79	5.63	9.94	1.88	0.47	3.30	85	94	102	120	132	147
35	2.938	80	3.75	101	6.63	13.06	2.25	0.55	4.15	97	107	119	137	150	168

Dimensions are shown for standard AJ hubs unless otherwise specified.

Size	HP/100 RPM	Rated Torque (lb-in)	Peak O/L Torque (lb-in)	Weight (lbs) (1)		WR <sup>2</sup> (lb-in <sup>2</sup> ) (1)		Misalignment Capacity	
				at D min	Add Per Inch of D	at D min	Add Per Inch of D	Axial (+/-in)	Angular (Degrees/Disc Pack)
5	0.48	300	600	2.71	0.11	1.93	0.03	0.015	1°
10	1.27	800	1,600	4.14	0.10	4.83	0.07	0.020	
15	2.5	1,575	3,150	6.14	0.10	9.36	0.07	0.021	
20	3.49	2,200	4,400	8.69	0.21	15.36	0.22	0.027	
25	6.03	3,800	7,600	14.98	0.20	42.07	0.29	0.030	
30	11	6,930	13,860	22.78	0.29	84.97	0.56	0.032	
35	18	11,340	22,680	32.02	0.40	170.84	1.32	0.042	

1) Weight and WR<sup>2</sup> values shown are for AJ hubs at max inch bore and spacer length at D Min

### STANDARD MATERIALS (CLASS A)

HUBS - CARBON STEEL  
 SPACER - CARBON STEEL  
 HARDWARE - ALLOY STEEL  
 DISC PACK - STAINLESS STEEL

### ORDERING

A5 Series couplings are sold as complete assemblies. Please specify hub types and bore sizes, DBSE (D) dimension, speed for dynamic balancing, and material class. A coupling will be configured to meet your specifications.

### MATERIAL / FINISH OPTIONS

CLASS A - Steel hubs and spacer, alloy steel hardware, 300 series stainless steel disc pack  
 CLASS B - Zinc plated steel hubs, and spacer, alloy steel hardware, 300 series stainless steel disc pack  
 CLASS C - Zinc plated steel hubs, and spacer, stainless steel hardware, 300 series stainless steel disc pack  
 CLASS E - 300 series stainless steel hubs and spacer, stainless steel hardware, 300 series stainless steel disc pack  
 (Only available for sizes 15 thru 35)



# Floating Shaft Spacer Coupling G5 Series - Form-Flex®

## Double Flex Floating Shaft



Size	Torque Rating			Weight (1) (lb)		WR <sup>2</sup> (1) (lb-in <sup>2</sup> )		Misalignment Capacity (Deg/Disc)	
	HP / 100 (RPM)	Max Continuous (lb-in)	Peak Overload (lb-in)	at D Min	Add Per Inch	at D Min	Add Per Inch	Axial (+/- in)	Angular (Degrees/Disc Pack)
311	17	11,000	22,000	22.67	0.39	86.75	1.28	0.028	0.5°
321	33	20,500	41,000	32.24	0.44	148.2	1.88	0.0290	
332	51	32,000	64,000	47.06	0.47	271.2	2.24	0.030	
346	73	46,000	92,000	77.73	1.11	568.7	6.95	0.050	
380	127	80,000	160,000	102.5	1.17	944.6	8.04	0.080	
412	190	120,000	240,000	151.5	2.04	1,972.6	19.15	0.080	0.33°
419	301	190,000	380,000	248.2	2.21	4,137	24.24	0.100	
424	476	300,000	600,000	358.3	3.04	9,456	63.33	0.100	
444	690	435,000	870,000	502.2	3.38	15,621	86.52	0.110	
456	1015	640,000	1,280,000	633.6	4.89	24,595	147.92	0.120	
483	1317	830,000	1,660,000	880.0	5.11	37,972	169.02	0.130	
511	1904	1,200,000	2,400,000	1132	5.11	64,246	169.02	0.140	
520	3173	2,000,000	4,000,000	CONSULT TB WOOD'S				0.180	
525	3967	2,500,000	5,000,000					0.200	
530	4760	3,000,000	6,000,000					0.200	
540	6347	4,000,000	8,000,000					0.240	

1) Weight and WR<sup>2</sup> values shown are for standard at max inch bore and spacer length at D Min

### STANDARD MATERIALS

HUBS - CARBON STEEL

SPACER - CARBON STEEL

HARDWARE - ALLOY STEEL

DISC PACK - STAINLESS STEEL

### MATERIAL OPTIONS

DISC PACK - ALLOY STEEL (for cost reduction, only available on sizes 412 to 540)

ZINC ELECTRO PLATING

ZINC PHOSPHATE COATING

ALLOY STEEL HUBS

### DESIGN VARIATIONS

- G5 - Welded Steel Tube
- G6 - Welded Steel Tube—Vertical
- G7 - Welded Steel Tube—Semi-Floating Spacer
- G5C - Composite Tube
- G6C - Composite Tube—Vertical
- G7C - Composite Tube— Semi-Floating

# Floating Shaft Spacer Coupling G5 Series - Form-Flex®

## Double Flex Floating Shaft

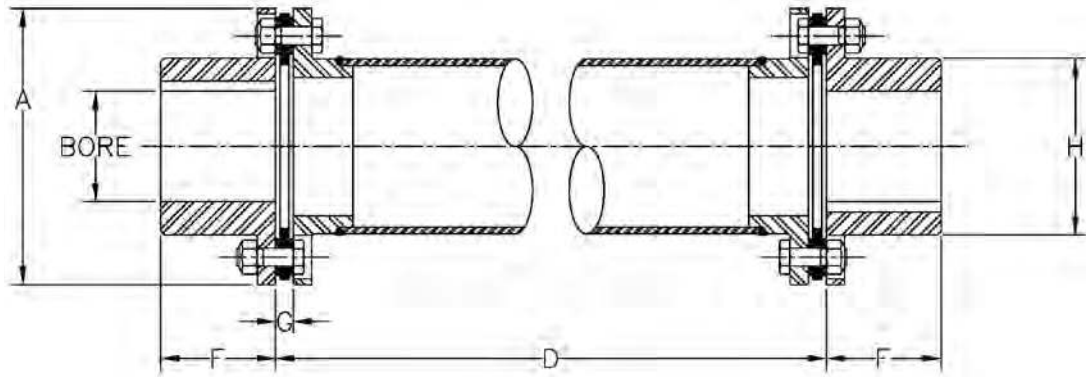

Size	Max Bore						Common Coupling Dimensions (in)								Max D (in) for RPM Shown					
	Standard Hub			Oversized/Large Hub			A	D Min	F	G	H		Tube		1800	1500	1200	900	750	600
	Square Key (in)	Rect. Key (in)	Rect. Key (mm)	Square Key (in)	Rect. Key (in)	Rect. Key (mm)					Std Hub	O/S Hub	OD	ID						
311	2.813	3.063	78	3.125	3.313	86	5.88	12.750	2.50	0.40	3.91	4.30	3.75	3.51	94	103	116	134	146	164
321	3.000	3.250	83	3.250	3.438	90	6.38	13.063	3.00	0.55	4.25	4.57	4.25	4.01	101	110	124	143	156	175
332	3.188	3.313	87	3.438	3.688	95	7.20	13.188	3.00	0.61	4.50	4.95	4.50	4.26	104	114	127	147	161	180
346	3.750	4.000	107	4.250	4.500	117	8.20	19.188	3.00	0.62	5.42	5.95	5.25	4.75	111	122	136	157	172	192
380	3.750	4.000	105	4.250	4.500	118	9.42	19.750	4.13	0.89	5.65	6.30	5.50	5.00	114	125	140	161	177	197
412	4.500	4.500	120	4.750	5.125	135	11.00	19.438	4.25	0.75	6.51	7.20	6.50	5.75	123	135	151	174	191	213
419	4.500	4.875	130	5.500	5.625	150	12.50	19.938	5.00	0.98	7.32	8.07	7.00	6.25	128	140	157	181	198	222
424	6.880	6.625	190				15.00	19.938	6.25	0.98	9.57		9.50	8.75	150	164	184	212	233	260
444	7.000	7.375	200				16.38	20.125	7.00	1.09	10.52		10.50	9.75	158	173	194	224	245	274
456	8.000	8.000	220				18.00	20.625	7.25	1.32	11.63		11.50	10.50	165	181	202	233	256	286
483	8.250	8.875	234				19.44	20.750	8.50	1.39	12.56		12.00	11.00	168	184	206	238	261	292
511	10.000	10.125	280				22.00	21.063	9.00	1.56	14.50		12.00	11.00	168	184	206	238	261	292
520	10.375	11.000	297				24.88	21.750	11.88	1.89	15.96									
525	11.000	12.000	322				26.75	21.875	12.00	1.95	17.35									
530	11.500	12.750	338				28.00	22.250	12.75	2.14	18.35									
540	15.750	17.000	448				33.50	24.125	15.00	2.58	22.63									

### ORDERING

G5 SERIES COUPLINGS ARE SOLD AS COMPLETE ASSEMBLIES  
 PLEASE SPECIFY BORE SIZES, DISC PACK MATERIAL AND DBSE.  
 A COUPLING WILL BE CONFIGURED TO MEET YOUR SPECIFICATIONS.

# Floating Shaft Spacer Coupling A5C/B5C Composite Series - Form-Flex®

## Double Flex Spacer

Form-Flex® flexible couplings may be mated to composite tubes for use as long floating shaft couplings. All types and most sizes of Form-Flex® couplings can be mated to composite tubes. Common combinations are shown below.

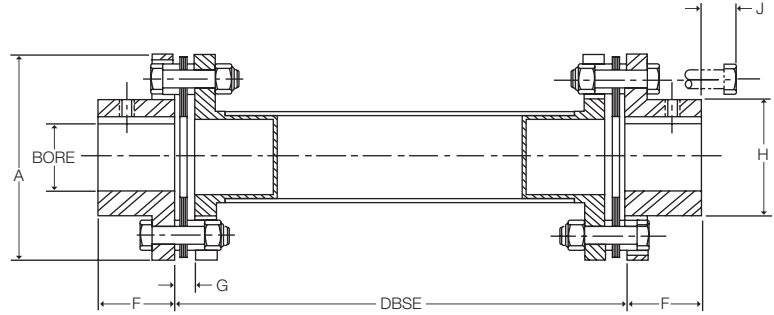

Type	Rated Torque lb-in	HP/100 RPM	Coupling Product No.	Maximum DBSE (in)			Maximum Bore			
				Max	1800 RPM	1500 RPM	Std Hub		AZ Hub	
							Square Key (in)	Reduced Key (in[mm])	Square Key (in)	Reduced Key (in[mm])
A5C20	2,200	3.49	A5C20_2G	84	70	77	1.625	1.75 [45]	2.125	2.188 [57]
			A5C20_2R	84	84*	84*				
A5C25	3,800	6.03	A5C25_2G	83	70	77	2.00	2.063 [52]	2.500	2.750 [68]
			A5C25_2R	83	83*	83*				
A5C30	6,930	11	A5C30_3R	130	103	114	2.375	2.438 [61]	2.875	3.063 [78]
			A5C30_3B	130	118	129				
A5C35	11,340	18	A5C35_4R	147	119	131	2.875	3.125 [80]	3.750	3.75 [100]
			A5C35_4B	147	135	147*				
			A5C35_6R	181	144	152				
			A5C35_6B	181	164	181*				
			A5C35_8R	196	178	196*				
A5C40	18,270	29	A5C40_4R	147	119	131	3.250	3.375 [88]	4.000	4.375 [113]
			A5C40_4B	147	135	147*				
B5C58	34,000	54	B5C58_6R	180	145	152	4.000	4.250 [110]	5.000	5.500 [143]
			B5C58_6B	180	164	180*				
			B5C58_6X	180	168	180*				
			B5C58_8R	197	178	196				
			B5C58_8B	197	190	196				
			B5C58_10R**	237	209	230				
B5C58_10B**	237	211	232							

Type	Dimensions (in)					Misalignment Capacity	
	A	F	G	H	J	Axial (+/- in)	Angular (Degrees/Disc Pack)
A5C20	4.08	1.32	0.34	2.4	2.3	0.055	1°
					2.3		
A5C25	4.95	1.62	0.45	2.8	2.3	0.060	1°
					2.3		
A5C30	5.63	1.88	0.47	3.3	3.25	0.065	1°
					3.25		
A5C35	6.63	2.25	0.55	4.15	4.25	0.085	1°
					4.25		
					6.3		
					6.3		
					8.31		
A5C40	7.63	2.50	0.60	4.65	4.25	0.100	1°
					4.25		
B5C58	8.98	2.75	0.56	5.81	6.3	0.118	0.7°
					6.3		
					6.3		
					8.31		
					8.31		
					10.31		

\* Length is restricted by available mandrels for winding composite tubes. Consult factory for longer lengths.

\*\* Tube diameter is larger than coupling "A" diameter.

Consult factory for coupling drawing.

# Floating Shaft Spacer Coupling A5C/B5C Composite Series - Form-Flex®

## QUICK SELECTION GUIDE FOR COOLING TOWER APPLICATIONS

1800 RPM				Coupling Model	1500 RPM			
DBSE		Max Power			Max Power		Max DBSE	
mm	in	Kw	HP		Kw	HP	mm	in
1778	70	23	31	A5C20_2G	20	26	1952	77
		40	54	A5C25_2G	34	45		
2133*	84*	23	31	A5C20_2R	20	26	2133*	84*
2108*	83*	40	54	A5C25_2R	34	35	2108*	83*
2616	103	74	99	A5C30_3R	62	82	2889	114
2997	118	74	99	A5C30_3B	62	82	3290	129
3023	119	121	162	A5C35_4R	101	135	3321	131
		195	261	A5C40_4R	162	217		
3429	135	121	162	A5C35_4B	101	135	3734*	147*
		195	261	A5C40_4B	162	217		
3658	144	121	162	A5C35_6R	101	135	3853	152
		3683	145	B5C58_6R	302	405		
4166	164	121	162	A5C35_6B	101	135	4593*	181*
		362	486	B5C58_6B	302	405	4570*	180*
4267	168	362	486	B5C58_6X	302	405	4570*	181*
		121	162	A5C35_8R	101	135	4970*	196*
4521	178	362	486	B5C58_8R	302	405		
		4826	190	121	162	A5C35_8B	101	135
362	486			B5C58_8B	302	405		
5309	209	362	486	B5C58_10R	302	405	5843	230
5359	211	362	486	B5C58_10B	302	405	5883	232
5842	230	362	486	B5C58_12B	302	405	6020*	237*

All sections use a 2.0 service factor

## ORDER CODE

### A5C35\_6B

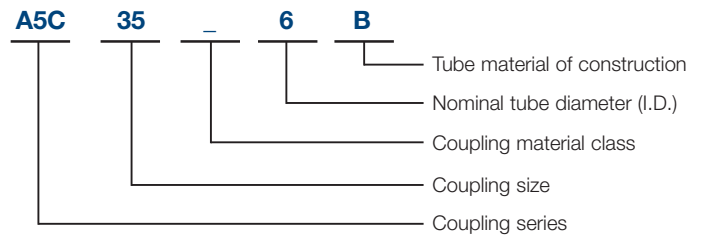

## COMPOSITE TUBE CONSTRUCTION

Model Code	Tube Material of Construction
G	GLASS
R	CARBON/GLASS HYBRID
B	STANDARD CARBON
X,Z	HIGH MODULUS CARBON

Material Class	Material Used		
	Hub	Hardware	Spacer Flanges
A	STEEL	STEEL	COMPOSITE OR STEEL
B	STEEL	STEEL, ZINC PLT	COMPOSITE OR
C	ZINC PLT	304SS	ZINC PLATED STEEL
E	304SS	304SS	COMPOSITE OR 304SS

Metal spacer flanges used if composite is not available.

\* Length is restricted by available mandrels for winding composite tubes. Consult factory for longer lengths.

\*\* Tube diameter is larger than coupling "A" diameter. Consult factory for coupling drawing.

# Close Coupled Couplings

---

## PRODUCT DESCRIPTION

- Used for close shaft spacing where traditional spacer couplings cannot be used
- Designed for moderate speed applications
- Construction includes:
  - Two fully machined steel hubs
  - One flat bar or machined block style spacer
  - Standard hardware and stainless steel disc packs
- Form-Flex® designs use non-unitized disc packs

Spacers are configured for minimal shaft separation. Shorter shaft separation is possible by allowing the shafts to extend through the disc packs into the center of the coupling. The shaft diameter must be less than the flex pack I.D. listed in the dimensional table.



## TYPICAL APPLICATIONS

- Machine Tools
- Ball Screws
- Pumps
- Printing Machines

## SPECIAL APPLICATIONS

- Elastomeric Coupling Replacement
- Cranes
- Gear Coupling Replacement

# Close Coupled Coupling AX Series - Form-Flex®

## General Use - Double Flex Short Spacer

The AX series close coupling is made up of two hubs, a steel spacer block, two stainless steel disc packs and AX hardware. A special bolting arrangement supports the spacer between the flex discs. The AX is an economical design that it well suited to many general purpose applications. The AX accommodates close shaft separations when it is installed with the shafts extending through the flex discs into the center of the coupling. The shaft diameter must be less than the disc pack I.D. listed in the dimensional table.

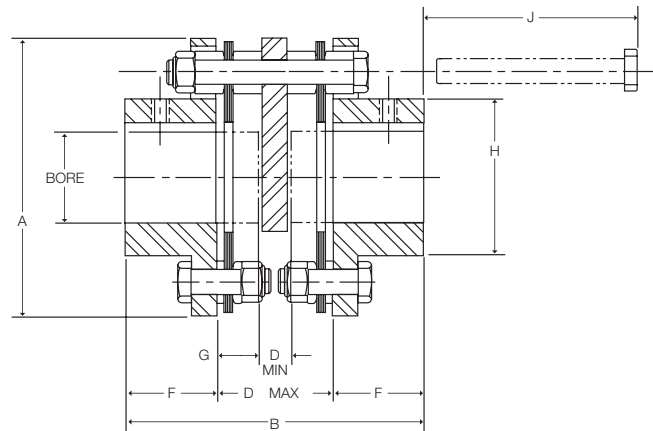

Size	Max Bore				Dimensions (in)*									DISC PACK I.D.**
	AJ		AZ		A	B	DBSE		F	G	H	J		
	(in)	(mm)	(in)	(mm)			D Min	D Max						
5	0.875	22	1.19	30	2.65	3.34	0.38	1.34	1.00	0.48	1.30	1.68	1.00	
10	1.250	33	1.63	43	3.19	3.40	0.44	1.40	1.00	0.48	1.30	1.79	1.17	
15	1.375	36	1.75	48	3.65	3.80	0.63	1.54	1.13	0.44	2.00	1.85	1.28	
20	1.688	46	2.13	58	4.08	4.22	0.63	1.58	1.32	0.48	2.40	1.66	1.65	
25	2.000	53	2.56	68	4.95	5.36	0.75	2.12	1.62	0.69	2.80	2.39	1.78	
30	2.380	63	2.88	79	5.63	6.30	1.00	2.54	1.88	0.77	3.30	3.18	2.01	
35	2.938	80	3.75	101	6.63	7.17	1.13	2.67	2.25	0.77	4.15	2.81	2.71	

\* Dimension shown are for AJ hubs unless otherwise specified.

\*\* Shaft O.D. must be less than Disc Pack I.D. in order to extend shafts into the coupling to meet D Min dimensions.

Size	HP/100 RPM	Rated Torque (lb-in)	Peak O/L Torque (lb-in)	Max RPM	Weight (lbs) (1)	WR <sup>2</sup> (lb-in <sup>2</sup> ) (1)	Misalignment Capacity	
							Axial (+/-in)	Angular (Degrees/Disc Pack)
5	0.48	300	450	8,500	1.63	1.26	0.015	1°
10	1.27	800	1,200	7,500	2.48	2.9	0.020	
15	2.5	1,575	2,363	6,700	3.84	5.8	0.021	
20	3.49	2,200	3,300	6,200	5.1	9.16	0.027	
25	6.03	3,800	5,700	5,500	9.13	26.1	0.030	
30	11	6,930	10,395	5,000	13.8	51.7	0.032	
35	18	11,340	17,010	4,400	21.1	108	0.042	

1) Weight and WR<sup>2</sup> values shown are for AJ hubs at max inch bore.

### STANDARD MATERIALS (CLASS A)

HUBS - CARBON STEEL

SPACER - CARBON STEEL

HARDWARE - ALLOY STEEL

DISC PACKS - STAINLESS STEEL

### ORDERING

AX SERIES COUPLINGS ARE SOLD AS COMPONENTS  
COUPLINGS CONSIST OF:

2 - HUBS - Example (AJ25A x 1-3/4")

1 - SPACER SUB-ASSEMBLY - Example (AX25SAA)

### STANDARD MATERIALS (CLASS A)

CLASS A - Mild steel hubs and spacer, alloy steel hardware, 300 series stainless steel disc packs

CLASS B - Zinc plated steel hubs, and spacer, alloy steel hardware, 300 series stainless steel disc packs

# Close Coupled Coupling AA Series - Form-Flex®

## General Use with Shorter Bolt Removal - Double Flex

The AA series close coupling is made up of two hubs, a cast iron block type spacer and two sets of standard hardware. Stainless steel disc packs are standard. The AA accommodates close shaft separations when it is installed with the shafts extending through the disc pack into the center of the coupling. The shaft diameter must be less than the disc pack I.D. listed in the dimensional table. This coupling is recommended when the bolt removal length (J) makes the AX coupling impractical.

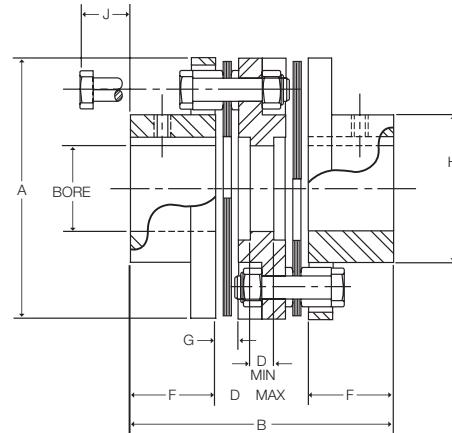

Size	Max Bore				Dimensions (in)*									Disc Pack I.D.**
	AJ		AZ		A	B	DBSE		F	G	H	J		
	(in)	(mm)	(in)	(mm)			D Min	D Max						
5	0.875	22	1.19	30	2.65	3.23	0.25	1.23	1.00	0.24	1.30	0.54	1.00	
10	1.250	33	1.63	43	3.19	3.73	0.25	1.73	1.00	0.27	1.80	0.56	1.17	
15	1.375	36	1.75	48	3.65	3.82	0.31	1.56	1.13	0.32	2.00	0.88	1.28	
20	1.688	46	2.13	58	4.08	4.38	0.41	1.74	1.32	0.34	2.40	0.79	1.65	
25	2.000	53	2.56	68	4.95	5.26	0.41	2.02	1.62	0.45	2.80	1.00	1.78	
30	2.380	63	2.88	79	5.63	6.24	0.56	2.48	1.88	0.47	3.30	1.14	2.01	
35	2.938	80	3.75	101	6.63	6.91	0.66	2.41	2.25	0.55	4.15	0.97	2.71	

\* Dimension shown are for AJ hubs unless otherwise specified.

\*\* Shaft O.D. must be less than Disc Pack I.D. in order to extend shafts into the coupling to meet D Min dimensions.

Size	HP/100 RPM	Rated Torque (lb-in)	Peak O/L Torque (lb-in)	Max RPM	Weight (lbs) (1)	WR <sup>2</sup> (lb-in <sup>2</sup> ) (1)	Misalignment Capacity	
							Axial (+/-in)	Angular (Degrees/Disc Pack)
5	0.48	300	450	3,600	1.76	1.4	0.015	1°
10	1.27	800	1,200	3,500	2.77	3.35	0.020	
15	2.5	1,575	2,363	3,450	4.24	6.66	0.021	
20	3.49	2,200	3,300	3,350	5.48	10.2	0.027	
25	6.03	3,800	5,700	3,200	9.81	29.4	0.030	
30	11	6,930	10,395	3,000	15.0	59.0	0.032	
35	18	11,340	17,010	2,800	22.4	121	0.042	

1) Weight and WR<sup>2</sup> values shown are for AJ hubs at max inch bore.

### STANDARD MATERIALS (CLASS A)

HUBS - CARBON STEEL  
 SPACER - CARBON STEEL  
 HARDWARE - ALLOY STEEL  
 DISC PACK - STAINLESS STEEL

### ORDERING

AX SERIES COUPLINGS ARE SOLD AS COMPONENTS  
 COUPLINGS CONSIST OF:  
 2 - HUBS - Example (AJ25A x 1-3/4")  
 1 - SPACER SUB-ASSEMBLY - Example (AA25SAA)

### MATERIAL / FINISH OPTIONS

CLASS A - Steel hubs and spacer, alloy steel hardware, 300 series stainless steel disc pack  
 CLASS B - Zinc plated steel hubs, and spacer, alloy steel hardware, 300 series stainless steel disc pack  
 CLASS C - Zinc plated steel hubs, and spacer, stainless steel hardware, 300 series stainless steel disc pack



# Close Coupled Coupling AY Series - Form-Flex®

## Positioning Applications - Double Flex Short Spacer

The AY series is specifically designed for positioning applications where a servo or stepper drive is C flange mounted and connects to a ball screw. The AY accommodates the small amounts of angular and parallel misalignment with an absolute minimum size package, zero backlash and high Torsional Stiffness. The AY is made up of two hubs, a steel spacer block, two stainless steel disc packs and AY hardware. The coupling must be installed as an assembled unit. The spacer is not service removable.

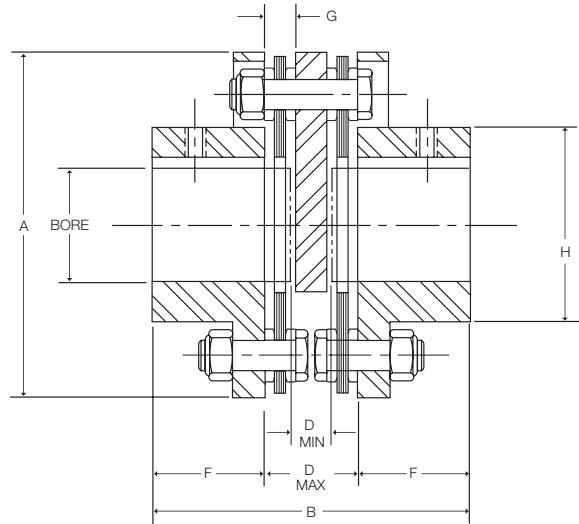

Size	Max Bore				Dimensions (in)*								
	AJ		AZ		A	B	DBSE		F	G	H	J	Disc Pack I.D.**
	(in)	(mm)	(in)	(mm)			D Min	D Max					
5	0.875	22	1.19	30	2.65	2.85	0.49	0.85	1.00	0.24	1.30	1.00	1.00
10	1.250	33	1.63	43	3.19	2.91	0.50	0.91	1.00	0.27	1.80	1.17	1.17
15	1.375	36	1.75	48	3.65	3.33	0.56	1.07	1.13	0.32	2.00	1.28	1.28
20	1.688	46	2.13	58	4.08	3.76	0.56	1.12	1.32	0.34	2.40	1.65	1.65
25	2.000	53	2.56	68	4.95	4.77	0.87	1.53	1.62	0.45	2.80	1.78	1.78

\* Dimension shown are for AJ hubs unless otherwise specified.

\*\* Shaft O.D. must be less than Disc Pack I.D. in order to extend shafts into the coupling to meet D Min dimensions.

Size	HP/100 RPM	Rated Torque (lb-in)	Peak O/L Torque (lb-in)	Max RPM	Weight (lbs) (1)	WR <sup>2</sup> (lb-in <sup>2</sup> ) (1)	Misalignment Capacity	
							Axial (+/-in)	Angular (Degrees/Disc Pack)
5	0.48	300	600	8,500	1.64	1.24	0.015	1°
10	1.27	800	1,600	7,500	2.68	3.08	0.020	
15	2.5	1,575	3,150	6,700	4.23	6.41	0.021	
20	3.49	2,200	4,400	6,200	5.49	9.92	0.027	
25	6.03	3,800	7,600	5,500	9.78	27.6	0.030	

1) Weight and WR2 values shown are for AJ hubs at max inch bore.

### STANDARD MATERIALS (CLASS A)

HUBS - CARBON STEEL  
 SPACER - CARBON STEEL  
 HARDWARE - ALLOY STEEL  
 DISC PACK - STAINLESS STEEL

### ORDERING

AY SERIES COUPLINGS ARE SOLD AS COMPONENTS  
 COUPLINGS CONSIST OF:

- 2 - HUBS - Example (AJ25A x 1-3/4")
- 1 - SPACER SUB-ASSEMBLY - Example (AY25SAA)

### MATERIAL / FINISH OPTIONS

CLASS A - Mild steel hubs and spacer, alloy steel hardware, 300 series stainless steel disc pack  
 CLASS B - Zinc plated steel hubs, and spacer, alloy steel hardware, 300 series stainless steel disc pack

# Single Flex Couplings

## PRODUCT DESCRIPTION

- Single Flex Couplings accommodates angular and axial misalignment only
- Construction includes:
  - Two fully machined steel hubs
  - Standard hardware and stainless steel disc packs
- Form-Flex® A-Series designs use non-unitized disc packs
- Form-Flex® G-Series designs use unitized disc packs
- Not intended for elastomeric coupling replacement
- Hubs can be single plane balanced for higher speed applications
- Can be bored for any shaft configuration (see page 38 for hub design options)

## TYPICAL APPLICATIONS

- Should only be used in three bearing system
- Used in pairs for floating shaft arrangement
- Can be used in pairs to support other components
  - Clutches
  - Brakes
  - Sheaves
- Mixers
- Single coupling can be used to support a component when a self-aligning bearing is used

## SPECIAL APPLICATIONS

- Torque Monitoring Equipment

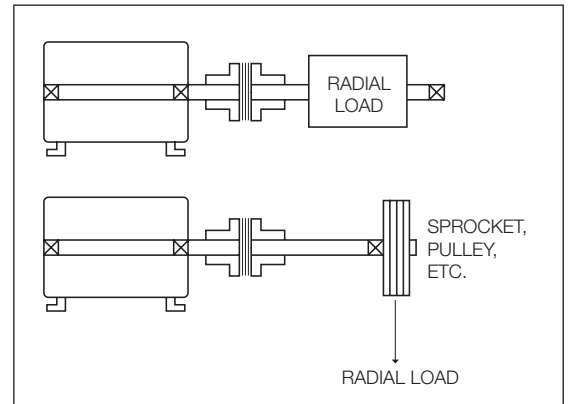

# Single Flex Coupling AR Series - Form-Flex®

## Single Flex Short Spacing

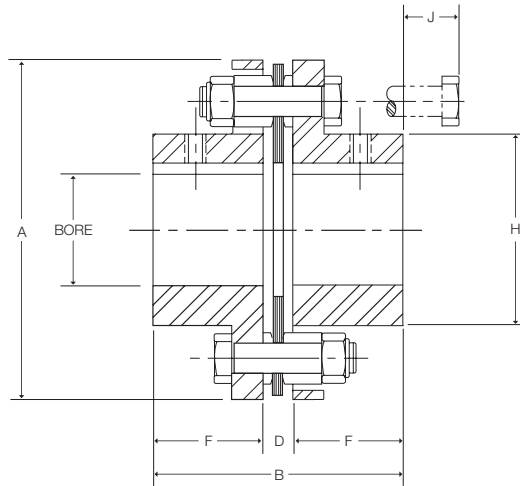

Size	Max Bore				Dimensions (in)*					
	AJ		AZ		A	B	D	F	H	J
	(in)	(mm)	(in)	(mm)						
5	0.875	22	1.19	30	2.65	2.24	0.24	1.00	1.30	0.54
10	1.250	33	1.63	43	3.19	2.27	0.27	1.00	1.80	0.59
15	1.375	36	1.75	48	3.65	2.58	0.32	1.13	2.00	0.88
20	1.688	46	2.13	58	4.08	2.98	0.34	1.32	2.40	0.79
25	2.000	53	2.56	68	4.95	3.69	0.45	1.62	2.80	1.00
30	2.380	63	2.88	79	5.63	4.23	0.47	1.88	3.30	1.14
35	2.938	80	3.75	101	6.63	5.05	0.55	2.25	4.15	0.97

\* Dimension shown are for AJ hubs unless otherwise specified.

Size	HP/100 RPM	Rated Torque (lb-in)	Peak O/L Torque (lb-in)	AGMA 7 Max RPM	Max Radial Load (lbs)	Weight (1) (lbs)	WR <sup>2</sup> (1) (lb-in <sup>2</sup> )	Misalignment Capacity	
								Axial (+/-in)	Angular (Degrees/Disc Pack)
5	0.48	300	600	8,500	34	1.24	0.96	0.015	1°
10	1.27	800	1,600	7,500	56	1.96	2.35	0.020	
15	2.5	1,575	3,150	6,700	125	2.98	4.62	0.021	
20	3.49	2,200	4,400	6,200	183	4.07	7.48	0.027	
25	6.03	3,800	7,600	5,500	275	7.01	20.4	0.030	
30	11	6,930	13,860	5,000	400	10.8	41.5	0.032	
35	18	11,340	22,680	4,400	600	17.2	88.3	0.042	

1) Weight and WR<sup>2</sup> values shown are for AJ hubs at max inch bore.

### STANDARD MATERIALS (CLASS A)

HUBS - CARBON STEEL

SPACER - CARBON STEEL

HARDWARE - ALLOY STEEL

DISC PACKS - STAINLESS STEEL

### ORDERING

AR SERIES COUPLINGS ARE SOLD AS COMPONENTS

COUPLINGS CONSIST OF:

2 - HUBS - Example (AJ25A x 1-3/4")

1 - REPAIR KIT - Example (A25RKA)

### MATERIAL / FINISH OPTIONS

CLASS A - Steel hubs, alloy steel hardware, 300 series stainless steel disc packs

CLASS B - Zinc plated steel hubs and spacer, alloy steel hardware, 300 series stainless steel disc pack

CLASS C - Zinc plated steel hubs, stainless steel hardware, 300 series stainless steel disc packs

CLASS E - 300 series stainless steel hubs, stainless steel hardware, 300 series stainless steel disc packs

# Single Flex Coupling GR Series - Form-Flex®

## Single Flex Short Spacing



Size	Torque Rating			Max Speed (RPM)		Max Radial Load (lbs)	Weight (lbs) (1)	WR <sup>2</sup> (lb-in <sup>2</sup> ) (1)	Misalignment Capacity	
	HP / 100 (RPM)	Max Continuous (lb-in)	Peak Overload (lb-in)	AGMA 8	ABS. Max				Axial (+/- in)	Angular (Degrees/ Disc Pack)
311	17	11,000	22,000	8,000	13,000	360	11.0	41.5	0.014	0.5°
321	33	20,500	41,000	7,400	12,000	800	17.8	77.6	0.0145	
332	51	32,000	64,000	6,600	11,500	1,300	26.2	143	0.015	
346	73	46,000	92,000	6,100	9,000	1,300	38.1	271	0.025	
380	127	80,000	160,000	5,500	7,000	2,400	53.1	469	0.040	
412	190	120,000	240,000	5,200	6,000	2,400	72.5	935	0.040	0.33°
419	301	190,000	380,000	4,600	5,000	4,200	129.3	2092	0.050	
424	476	300,000	600,000	4,200	5,000	4,200	195.8	4936	0.050	
444	690	435,000	870,000	3,800	4,000	5,300	291.5	8422	0.055	
456	1015	640,000	1,280,000	3,600	3,500	6,700	364.0	13226	0.060	
483	1317	830,000	1,660,000	3,300	3,500	8,200	512.0	20843	0.065	
511	1904	1,200,000	2,400,000	3,100	3,000	9,800	677.2	37076	0.070	
520	3173	2,000,000	4,000,000	2,800	2,500	15,700	1208	71849	0.090	
525	3967	2,500,000	5,000,000	2,700	2,500	17,900	1473	113939	0.100	
530	4760	3,000,000	6,000,000	2,500	2,500	21,000	1752	148626	0.100	
540	6347	4,000,000	8,000,000	2,300	2,000	23,000	2662	346946	0.120	

1) Weight and WR<sup>2</sup> values shown are for standard hubs at max inch bore.

### STANDARD MATERIALS

HUBS - CARBON STEEL

SPACER - CARBON STEEL

HARDWARE - ALLOY STEEL

DISC PACKS - STAINLESS STEEL

### MATERIAL / FINISH OPTIONS

DISC PACKS - ALLOY STEEL (For cost reduction, available for sizes 412 to 540)

ZINC ELECTRO PLATING

ZINC PHOSPHATE COATING

ALLOY STEEL HUBS

# Single Flex Coupling GR Series - Form-Flex®

## Single Flex Short Spacing

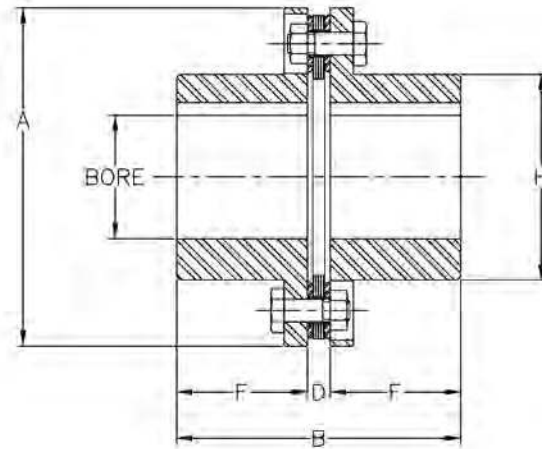

Size	Max Bore						Dimensions (in)						
	Standard Hub			Oversized/Large Hub			A	B	D DBSE	F	G	H	
	Square Key (in)	Rect. Key (in)	Rect. Key (mm)	Square Key (in)	Rect. Key (in)	Rect. Key (mm)						Std Hub	O/S Hub
311	2.813	3.063	78	3.125	3.313	86	5.88	5.40	0.40	2.50	0.40	3.91	4.30
321	3.000	3.250	83	3.250	3.438	90	6.38	6.55	0.55	3.00	0.55	4.25	4.57
332	3.188	3.313	87	3.438	3.688	95	7.20	6.62	0.62	3.00	0.61	4.50	4.95
346	3.750	4.000	107	4.250	4.500	117	8.20	6.62	0.62	3.00	0.62	5.42	5.95
380	3.750	4.000	105	4.250	4.500	118	9.42	9.14	0.89	4.13	0.89	5.65	6.30
412	4.500	4.500	120	4.750	5.125	135	11.00	9.25	0.75	4.25	0.75	6.51	7.20
419	4.500	4.875	130	5.500	5.625	150	12.50	10.98	0.98	5.00	0.98	7.32	8.07
424	6.880	6.625	190				15.00	13.48	0.98	6.25	0.98	9.57	
444	7.000	7.375	200				16.38	15.09	1.09	7.00	1.09	10.52	
456	8.000	8.000	220				18.00	15.82	1.32	7.25	1.32	11.63	
483	8.250	8.875	234				19.44	18.39	1.39	8.50	1.39	12.56	
511	10.000	10.125	280				22.00	19.56	1.56	9.00	1.56	14.50	
520	10.375	11.000	297				24.88	25.64	1.89	11.88	1.89	15.96	
525	11.000	12.000	322				26.75	25.95	1.95	12.00	1.95	17.35	
530	11.500	12.750	338				28.00	27.64	2.14	12.75	2.14	18.35	
540	15.750	17.000	448				33.50	32.58	2.58	15.00	2.58	22.63	

### ORDERING

GR SERIES COUPLINGS ARE SOLD AS COMPONENTS

COUPLINGS CONSIST OF:

2 - HUBS - Example (GH346 x 2-1/2")

1 - REPAIR KIT - Example (G346SF)

# Heavy Duty Spacer Coupling

## PRODUCT FEATURES

- Designed for low to medium speed equipment
- Standard designs for applications requiring shaft-to-shaft or shaft to flywheel connection.
- Construction
  - Fully machined steel hubs are standard
  - Ductile Iron or Class 30 Grey Iron spacer/spyder
  - Ductile Iron or Class 30 Grey Iron flywheel adapter
  - Alloy steel hardware and High Carbon steel disc packs
- Form-Flex® HSH/FSH Series designs use non-unitized disc packs
- Form-Flex® GCH/GCF Series designs use unitized disc packs
- Industry standard length spacer
- Can be bored for any shaft configuration (see page 38 & 39 for hub design options)
- Special flange mountings are also available to bolt custom flanges on any equipment.



## TYPICAL APPLICATIONS

- Reciprocating Compressors
- Metal Shredders
- Rock Crushers
- Engine Driven Equipment
- Mixer

## SPECIAL APPLICATIONS

- Can be modified for API671 with exceptions
- Added inertia to torsionally tune system
- Altered stiffness for torsional tuning
- Custom designs for demanding applications

## SPECIAL APPLICATIONS

Example: Coupling shown was specially designed for a high torque, low speed (10000HP @ 290RPM) application to torsionally tune the system. This is a 10 bolt disc pack design and the coupling is rated for 10,000,000 lb-in with an OD measuring 44.50". Flange mounted on both ends with a custom adapter hub on the motor's keyless shaft.



# Heavy Duty Spacer Coupling GCH Series - Form-Flex®

## Double Flex Spacer

Size	Spacer	Max Bore		Dimensions (in)					
		(in)	(mm)	A	B	D	F	G	H
340	31	3.75	100	8.38	9.89	4.14	5.44	0.57	2.88
	35				10.46	4.71			
412	42	4.50	120	11.00	14.07	5.57	6.51	0.75	4.25
	45				14.57	6.07			
	50				15.69	7.19			
424	55	6.88	190	15.00	19.95	7.45	9.57	0.98	6.25
	60				20.95	8.45			
456	70	8.00	220	18.00	24.13	9.63	11.63	1.32	7.25
	75				25.20	10.70			
511	80	10.00	280	22.00	29.39	11.39	14.5	1.56	9.00
	85				30.39	12.39			
	92				31.89	13.89			

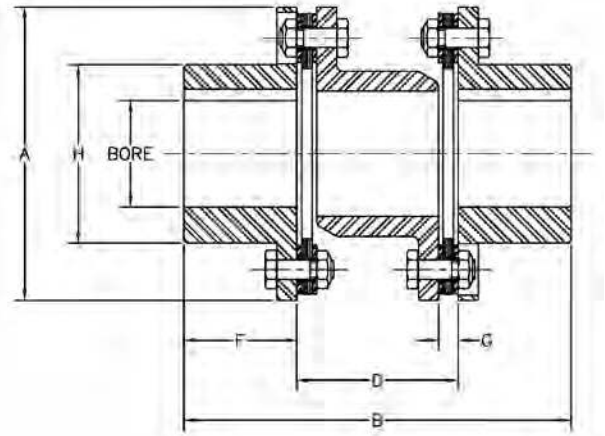

Size	Spacer	Rated Torque		Peak Overload (lb-in)	Max RPM	Weight (1) (lbs)	WR <sup>2</sup> (1) (lb-in <sup>2</sup> )	Misalignment Capacity	
		HP/100 RPM	(lb-in)					Axial +/- in	Angular (Degrees/Disc Pack)
340	31	64	40,000	60,000	3,400	43	344	0.06	0.33°
	35					44	349		
412	42	190	120,000	180,000	2,500	106	1,373	0.08	
	45					108	1,387		
	50					112	1,418		
424	55	380	240,000	360,000	1,800	278	7,157	0.1	
	60					284	7,277		
456	70	889	560,000	840,000	1,500	529	19,551	0.12	
	75					540	19,832		
511	80	1,746	1,100,000	1,650,000	1,200	965	54,405	0.14	
	85					981	55,046		
	92					1,016	61,098		

Note: Couplings available for torque capacity up to 1129815 Nm. Contact Altra Couplings engineering with application details for coupling selection.

### STANDARD MATERIALS

HUBS - CARBON STEEL

SPACER - DUCTILE IRON

HARDWARE - ALLOY STEEL

DISC PACKS - HIGH CARBON STEEL

### MATERIAL / FINISH OPTIONS

DISC PACKS - STAINLESS STEEL

ZINC PHOSPHATE COATING

ALLOY STEEL HUBS

STEEL SPACER

### NOTES:

- 1) Weight and WR<sup>2</sup> are calculated with hubs at maximum inch bore size.
- 2) Consult factory for torsional stiffness and alternating torque limits.

### ORDERING

GCH SERIES COUPLINGS ARE SOLD AS COMPLETE ASSEMBLIES

- 1) Specify coupling size and spacer option

Example: GCH424-60 5" x 6-1/4"

- 2) Specify hub bore size and tolerance, keyway size or keyless, special hub length, etc. Please specify for each hub.



# Heavy Duty Spacer Coupling GCF Series - Form-Flex®

## Double Flex Spacer

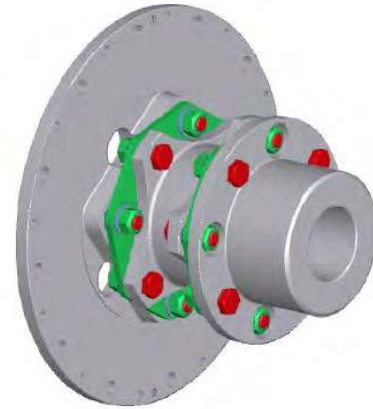
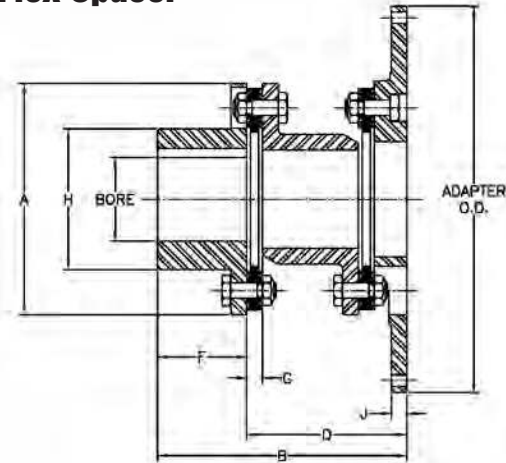

Size	Spacer	Max Bore		Dimensions (in)						
		(in)	(mm)	A	B	D	F	G	H	J
340	31	3.75	100	8.38	8.19	5.31	2.88	0.57	5.44	0.5
	35				8.76	5.88				
412	42	4.50	120	11.00	11.39	7.14	4.25	0.75	6.51	0.57
	45				11.89	7.64				
	50				13.01	8.76				
424	55	6.88	190	15.00	16.14	9.89	6.25	0.98	9.57	1
	60				17.14	10.89				
456	70	8.00	220	18.00	19.69	12.44	7.25	1.32	11.63	1.13
	75				20.76	13.51				
511	80	10.00	280	22.00	23.76	14.76	9.00	1.56	14.5	1.38
	85				24.76	15.76				
	92				26.26	17.26				

Size	Adapter O.D. / Standard Bolt Pattern						
	12.375	12.875	18.375	20.375	22.500	26.500	28.875
	12	14	18	20	22	26	28
340	Order	SAE	SAE	Order	SAE		
412			SAE	Order	SAE	SAE/HD	SAE/HD
424			SAE/HD	Order	SAE/HD	SAE/HD	SAE/HD
456					SAE/HD	SAE/HD	SAE/HD
511						SAE/HD	SAE/HD
SAE Bolting							
BC	11.625	13.125	17.25	19.25	21.375	25.25	27.25
Hole Qty	8	8	8	8	6	12	12
Hole Dia	0.41	0.41	0.53	0.53	0.65	0.65	0.78
HD Bolting							
BC	11.5	12.5	16.75	18.5	20.5	24.5	26.875
Hole Qty	8	8	8	8	8	12	12
Hole Dia	0.53	0.65	0.78	0.91	1.03	1.03	1.03
Speed Limit by Adapter O.D. (2b)							
RPM	3,400	3,400	2,900	2,600	2,400	2,000	1,800

Size	Spacer	Rated Torque		Peak Overload (lb-in)	Max RPM (2a)	Weight (1) (lb)	WR <sup>2</sup> (1) (lb-in <sup>2</sup> )	Misalignment Capacity	
		HP/100 RPM	(lb-in)					Axial (+/- in)	Angular (Degrees/Disc Pack)
340	31	64	40,000	60,000	3,400	46	561	0.06	0.33°
	35					47	566		
412	42	190	120,000	180,000	2,500	127	3,223	0.08	
	45					128	3,237		
	50					132	3,268		
424	55	380	240,000	360,000	1,800	260	8,258	0.1	
	60					267	8,378		
456	70	889	560,000	840,000	1,500	489	22,321	0.12	
	75					501	22,602		
511	80	1,746	1,100,000	1,650,000	1,200	871	58,922	0.14	
	85					887	59,563		
	92					922	65,615		

- 1) Weight and WR2 calculated with hub at maximum inch bore size and minimum available adapter size.
- 2) a) Max RPM shown for smallest available adapter size, do not exceed this speed for any given coupling size.  
b) Verify that adapter speed limit is adequate for application speed, do not exceed coupling MAX RPM (See note 2a).
- 3) Flywheel mounting hardware is not supplied with coupling.
- 4) Consult factory for torsional stiffness and alternating torque limits.

### ORDERING

- 1) Specify coupling size and spacer option  
Example: GCF424-60
- 2) Specify adapter size code. Specify bolting pattern for items noted as drilled per order.  
Example: GCF424-60-26 or GCF424-60-22HD
- 3) Specify hub bore size and tolerance, keyway size or keyless, special hub length, etc.

### STANDARD MATERIALS

HUB - CARBON STEEL  
 SPACER - DUCTILE IRON  
 FLYWHEEL ADAPTER - DUTILE IRON  
 HARDWARE - ALLOY STEEL  
 DISC PACKS - HIGH CARBON STEEL

# Heavy Duty Spacer Coupling HSH Series - Form-Flex®

## Double Flex Spacer

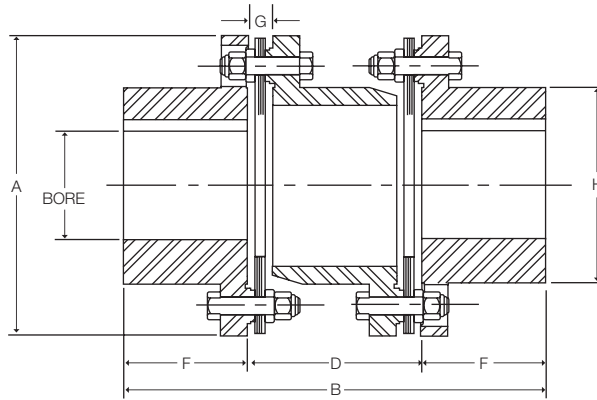

Size	Dimensions (in)									
	Max Bore				A (2)	B	D DBSE	F	G	H
	Iron		Steel							
(in)	(mm)	(in)	(mm)							
22	-	-	2.75	79	5.88	8.00	3.02	2.50	0.43	3.87
26	-	-	3.25	92	6.88	9.50	3.50	2.88	0.55	4.50
31	3.12	82	4.13	113	8.12	10.87	4.12	3.37	0.62	5.50
35	3.62	97	4.50	125	9.12	12.06	4.57	3.75	0.66	6.12
37	3.75	100	4.63	130	10.06	13.12	5.14	4.00	0.81	6.50
42	4.25	114	5.00	142	11.00	13.93	5.43	4.25	0.81	7.00
45	4.50	120	5.50	150	11.87	14.75	5.75	4.50	0.87	7.43
50	-	-	6.13	170	13.00	16.81	6.81	5.00	1.06	8.37
55	-	-	6.88	193	15.00	18.68	7.68	5.50	1.25	9.50
60	-	-	7.50	212	16.00	20.93	8.43	6.25	1.34	10.50
70	-	-	8.50	233	18.50	23.62	9.56	7.00	1.50	11.75
75	-	-	9.00	261	20.00	25.00	10.50	7.25	1.53	13.00
80	-	-	9.12	275	22.00	26.87	11.37	7.75	1.56	13.75
85	-	-	10.38	290	23.75	28.62	12.12	8.25	1.62	14.50
92	-	-	11.00	320	25.75	31.00	13.01	9.00	1.75	15.87
92HT	-	-	10.50	307	25.75	31.00	13.01	9.00	1.75	15.87

### STANDARD MATERIALS

HUBS - CARBON STEEL  
 SPACER - GREY OR DUCTILE IRON  
 HARDWARE - ALLOY STEEL  
 DISC PACKS - HIGH CARBON STEEL

### MATERIAL / FINISH OPTIONS

DISC PACKS - STAINLESS STEEL  
 ZINC PHOSPHATE COATING  
 ALLOY STEEL HUBS  
 CAST IRON HUBS  
 (Sizes 31-45)

Size	HP/ 100 RPM	Rated Torque (lb-in)	Peak O/L Torque (lb-in)	Max RPM	Weight (lbs) (1)	WR <sup>2</sup> (lb-in <sup>2</sup> ) (1)	Misalignment Capacity	
							Axial (+/- in)	Angular (Degrees/ Discpack)
22	15.1	9,500	14,250	3,800	19.7	75.6	0.036	0.33°
26	25.4	16,000	24,000	3,300	28.8	152	0.044	
31	38.1	24,000	36,000	2,800	51.4	390	0.052	
35	69.8	44,000	66,000	2,600	76.7	738	0.056	
37	95.2	60,000	90,000	2,500	92.4	1,090	0.062	
42	116	73,000	109,500	2,400	125	1,710	0.067	
45	157	99,000	148,500	2,250	154	2,510	0.072	
50	203	128,000	192,000	2,000	218	4,570	0.082	
55	300	189,000	283,500	1,800	288	7,400	0.092	
60	414	261,000	391,500	1,600	403	13,100	0.102	
70	659	415,000	622,500	1,400	624	25,800	0.115	
75	846	533,000	799,500	1,300	788	37,900	0.125	
80	1,087	685,000	1,027,500	1,200	1,030	58,700	0.136	
85	1,316	829,000	1,243,500	1,100	1,230	79,000	0.140	
92	1,651	1,040,000	1,560,000	1,000	1,630	129,000	0.156	
92HT	2,221	1,400,000	2,100,000	1,000	1,680	137,000	0.156	

- 1) Weight and WR<sup>2</sup> are calculated with steel hubs at maximum inch bore size.
- 2) Consult factory for torsional stiffness and alternating torque limits.

### ORDERING

HSH SERIES COUPLINGS ARE SOLD AS COMPLETE ASSEMBLIES (Components and repair kits are available for repairs)

- 1) Specify coupling
- 2) Specify hub bore size and tolerance, keyway size or specify for each hub.
- 3) Specify disc pack material

# Heavy Duty Spacer Coupling FSH Series - Form-Flex®

## Double Flex Spacer

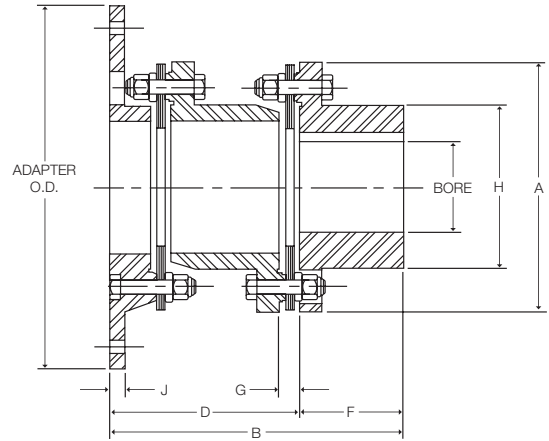

Adapter O.D. / Standard Bolt Pattern						
12.375	12.875	18.375	20.375	22.500	26.500	28.875
12	14	18	20	22	26	28

SAE Bolting							
BC	11.625	13.125	17.25	19.25	21.375	25.25	27.25
Hole Qty	8	8	8	8	6	12	12
Hole Dia	0.41	0.41	0.53	0.53	0.65	0.65	0.78
HD Bolting							
BC	11.5	12.5	16.75	18.5	20.5	24.5	26.875
Hole Qty	8	8	8	8	8	12	12
Hole Dia	0.53	0.65	0.78	0.91	1.03	1.03	1.03

### STANDARD MATERIALS

HUBS - CARBON STEEL  
 SPACER - DUCTILE IRON OR CAST IRON  
 FLYWHEEL ADAPTER - DUCTILE IRON OR CAST IRON  
 HARDWARE - ALLOY STEEL  
 DISC PACKS - HIGH CARBON STEEL

Size	Max Bore				Dimensions (in)							Available Adapter Sizes							
	Iron		Steel		A	B	D DBSE	F	G	H	J	X = Stock Size 0 = MTO							
	(in)	(mm)	(in)	(mm)								10	12	14	18	20	22	26	28
31	3.12	82	4.13	113	8.12	8.68	5.31	3.37	0.62	5.50	0.50	O	O	X	X	O	O		
35	3.62	97	4.50	125	9.12	9.62	5.87	3.75	0.66	6.12	0.50	O	O	X	X	O	O		
37	3.75	100	4.63	130	10.06	10.62	6.62	4.00	0.81	6.50	0.56			O	O	O	O		
42	4.25	114	5.00	142	11.00	11.37	7.12	4.25	0.81	7.00	0.63			O	X	O	X	X	O
45	4.50	120	5.50	150	11.87	12.00	7.50	4.50	0.87	7.43	0.69			O	X	O	X	X	O
50	-	-	6.13	170	13.43	13.75	8.75	5.00	1.06	8.37	0.75				X	O	X	X	X
55	-	-	6.88	193	15.00	15.38	9.81	5.50	1.25	9.50	0.88				X	O	X	X	X
60	-	-	7.50	212	16.75	17.12	10.87	6.25	1.34	10.50	1.00				X	O	X	X	X
70	-	-	8.50	233	18.93	19.43	12.43	7.00	1.50	11.75	1.00					X	X	X	X
75	-	-	9.00	261	20.62	20.75	13.50	7.25	1.53	13.00	1.13					O	O	X	X
80	-	-	9.12	275	22.37	22.50	14.75	7.75	1.56	13.75	1.25						O	X	X
85	-	-	10.38	290	23.75	23.93	15.75	8.25	1.62	14.50	1.25							X	X
92	-	-	11.00	320	25.75	26.25	17.25	9.00	1.75	15.87	1.38							X	X
92HT	-	-	10.50	307	25.75	26.25	17.25	9.00	1.75	15.87	1.38							X	X

Size	HP/ 100 RPM	Rated Torque (lb-in)	Peak O/L Torque (lb-in)	Max RPM (2)	Weight (lbs) (1)	WR <sup>2</sup> (lb-in <sup>2</sup> ) (1)	Misalignment Capacity	
							Axial +/- in	Angular (Degrees/ Disc Pack)
31	38.1	24,000	36,000	2,800	43.8	410	0.052	0.33°
35	69.8	44,000	66,000	2,600	62.1	659	0.056	
37	95.2	60,000	90,000	2,500	83.5	1,290	0.062	
42	116	73,000	109,500	2,400	109	1,780	0.067	
45	157	99,000	148,500	2,250	131	2,400	0.072	
50	203	128,000	192,000	2,000	197	5,390	0.082	
55	300	189,000	283,500	1,800	251	7,700	0.092	
60	414	261,000	391,500	1,600	333	11,900	0.102	
70	659	415,000	622,500	1,400	540	25,300	0.115	
75	846	533,000	799,500	1,300	682	35,200	0.125	
80	1,087	685,000	1,027,500	1,200	905	58,400	0.136	
85	1,316	829,000	1,243,500	1,100	1,080	80,100	0.140	
92	1,651	1,040,000	1,560,000	1,000	1,400	120,000	0.156	
92HT	2,221	1,400,000	2,100,000	1,000	1,450	129,000	0.156	

### ORDERING

FSH SERIES COUPLINGS ARE SOLD AS COMPLETE ASSEMBLIES (Components and repair kits are for repairs)

- 1) Specify coupling size and adapter size
- 2) Specify hub bore size and tolerance, keyway keyless, special hub length, etc.
- 3) Specify disc pack material

1) Weight and WR<sup>2</sup> calculated with steel hubs at maximum inch bore size and minimum available adapter size.  
 2) a) Max RPM shown for smallest available adapter size, do not exceed this speed for any given coupling size.  
 b) Verify that adapter speed limit is adequate for application speed, do not exceed coupling MAX RPM (See note 2a).  
 3) Flywheel mounting hardware is not supplied with coupling.  
 4) Consult factory for torsional stiffness and alternating torque limits.



# Coupling Repair Parts and Kits

Notes:

- 1) Single Repair Kits include 1 disc pack and all bolts, nuts and washers for use with 1 disc pack
- 2) Single hardware Kits include all bolts, nuts and washers for use with 1 disc pack
- 3) Double Repair Kits include 2 disc packs and all hardware for one coupling
- 4) Double hardware kits include all bolt, nuts and washers for one coupling

## Form-Flex® (A Series)

Kit Type	Repair				Hardware				Disc Pack	Rough Bore Hub									
SGL/DBL	Single								Double		Double		AJ (Std)			AZ (O/S)			
Used On	AA, AP, AR, A5, A6, A7								AX		AY		All	All	All	All	All	All	All
Mat'l Class	A,B	C,E	A,B	C,E	A,B	A,B	A,B	A,B	A,B	All	A	B,C	E	A	B,C	E			
5	A05RKA	***	A05HKA	***	AX05RKA	AX05HKA	AY05RKA	AY05HKA	A005-4101	AJ05RBA	AJ05RBB	***	AZ05RBA	AZ05RBB	***				
10	A10RKA	***	A10HKA	***	AX10RKA	AX10HKA	AY10RKA	AY10HKA	A010-4101	AJ10RBA	AJ10RBB	***	AZ10RBA	AZ10RBB	***				
15	A15RKA	A15RKE	A15HKA	A15HKE	AX15RKA	AX15HKA	AY15RKA	AY15HKA	A015-4101	AJ15RBA	AJ15RBB	AJ15RBE	AZ15RBA	AZ15RBB	AZ15RBE				
20	A20RKA	A20RKE	A20HKA	A20HKE	AX20RKA	AX20HKA	AY20RKA	AY20HKA	A020-4101	AJ20RBA	AJ20RBB	AJ20RBE	AZ20RBA	AZ20RBB	AZ20RBE				
25	A25RKA	A25RKE	A25HKA	A25HKE	AX25RKA	AX25HKA	AY25RKA	AY25HKA	A025-4101	AJ25RBA	AJ25RBB	AJ25RBE	AZ25RBA	AZ25RBB	AZ25RBE				
30	A30RKA	A30RKE	A30HKA	A30HKE	AX30RKA	AX30HKA	***	***	A030-4101	AJ30RBA	AJ30RBB	AJ30RBE	AZ30RBA	AZ30RBB	AZ30RBE				
35	A35RKA	A35RKE	A35HKA	A35HKE	AX35RKA	AX35HKA	***	***	A035-4101	AJ35RBA	AJ35RBB	AJ35RBE	AZ35RBA	AZ35RBB	AZ35RBE				

## Form-Flex® (A5C/B5C Series)

Kit Type	Repair				Hardware				Disc Pack
SGL/DBL	Single								Double
Used On	A5C, B5C								All
Mat'l Class	A,B	C,E	A,B	C,E	A,B	C,E	A,B	C,E	All
15	A5C15RKA	A5C15RKE	A5C15HKA	A5C15HKE	A5C15RKA-DF	A5C15RKE-DF	A5C15HKA-DF	A5C15HKE-DF	A015-4101
20	A5C20RKA	A5C20RKE	A5C20HKA	A5C20HKE	A5C20RKA-DF	A5C20RKE-DF	A5C20HKA-DF	A5C20HKE-DF	A020-4101
25	A5C25RKA	A5C25RKE	A5C25HKA	A5C25HKE	A5C25RKA-DF	A5C25RKE-DF	A5C25HKA-DF	A5C25HKE-DF	A025-4101
30	A5C30RKA	A5C30RKE	A5C30HKA	A5C30HKE	A5C30RKA-DF	A5C30RKE-DF	A5C30HKA-DF	A5C30HKE-DF	A030-4101
35	A5C35RKA	A5C35RKE	A5C35HKA	A5C35HKE	A5C35RKA-DF	A5C35RKE-DF	A5C35HKA-DF	A5C35HKE-DF	A035-4101
58	B5C58RKA	B5C58RKE	B5C58HKA	B5C58HKE	B5C58RKA-DF	B5C58RKE-DF	B5C58HKA-DF	B5C58HKE-DF	B058-4101

## Torsiflex-i (TF Series)

Kit Type	Repair Kit	Hardware Kit (1)	Disc Pack (2)	Hub Attachment Screw Kit (3)	Rough Bore Hub	
Cplg Size	Disc Pack		300 Series S.S		Std	Oversize
0017	TF0017EK	TF0017HK	TF0017-5-SS	TF0017HAS	TF0027AH	TF0017LAH
0027	TF0027EK	TF0027HK	TF0027-5-SS	TF0027HAS	TF0027AH	TF0027LAH
0038	TF0038EK	TF0038HK	TF0038-5-SS	TF0038HAS	TF0038AH	TF0038LAH
0140	TF0140EK	TF0140HK	TF0140-5-SS	TF0140HAS	TF0140AH	-
0260	TF0260EK	TF0260HK	TF0260-5-SS	TF0260HAS	TF0260AH	-
0400	TF0400EK	TF0400HK	TF0400-5-SS	TF0400HAS	TF0400AH	-
0750	TF0750EK	TF0750HK	TF0750-5-SS	TF0750HAS	TF0750AH	-
1310	TF1310EK	TF1310HK	TF1310-5-SS	TF1310HAS	TF1310AH	-
1900	TF1900EK	TF1900HK	TF1900-5-SS	TF1900HAS	TF1900AH	-
2500	TF2500EK	TF2500HK	TF2500-5-SS	TF2500HAS	TF2500AH	-
3300	TF3300EK	TF3300HK	TF3300-5-SS	TF3300HAS	TF3300AH	-
6000	TF6000EK	TF6000HK	TF6000-5-SS	TF6000HAS	TF6000AH	-
8500	TF8500EK	TF8500HK	TF8500-5-SS	TF8500HAS	TF8500AH	-
12000	TF12000EK	TF12000HK	TF12000-5-SS	TF12000HAS	TF12000AH	-

- 1) Contains bolts, nuts and washers for 1 disc pack, 2 required for a complete coupling
- 2) Includes 1 complete disc pack, 2 required for a complete coupling
- 3) Contains all fasteners for 1 hub, 2 required for a complete coupling

# Coupling Repair Parts and Kits (Cont.)

## Form-Flex® (G Series)

Kit Type	Repair Kits				Hardware Kit	Disc Pack		Rough Bore Hub	
Used On	Double		Single		Single (1)	SS	CS	Std	Oversize
Mat'l Class	Disc Pack	Disc Pack	Disc Pack	Disc Pack					
311	G311-DF-SS	-	G311-SF-SS	-	G311-HK	G311-5-SS	-	G311-3ST	G311-3LST
321	G321-DF-SS	-	G321-SF-SS	-	G321-HK	G321-5-SS	-	G321-3ST	G321-3LST
332	G332-DF-SS	-	G332-SF-SS	-	G332-HK	G332-5-SS	-	G332-3ST	G332-3LST
346	G346-DF-SS	-	G346-SF-SS	-	G346-HK	G346-5-SS	-	G346-3ST	G346-3LST
380	G380-DF-SS	-	G380-SF-SS	-	G380-HK	G380-5-SS	-	G380-3ST	G380-3LST
412	G412-DF-SS	G412-DF	G412-SF-SS	G412-SF	G412-HK	G412-5-SS	G412-5	G412-3ST	G412-3LST
419	G419-DF-SS	G419-DF	G419-SF-SS	G419-SF	G419-HK	G419-5-SS	G419-5	G419-3ST	G419-3LST
424	G424-DF-SS	G424-DF	G424-SF-SS	G424-SF	G424-HK	G424-5-SS	G424-5	G424-3ST	-
444	G444-DF-SS	G444-DF	G444-SF-SS	G444-SF	G444-HK	G444-5-SS	G444-5	G444-3ST	-
456	G456-DF-SS	G456-DF	G456-SF-SS	G456-SF	G456-HK	G456-5-SS	G456-5	G456-3ST	-
483	G483-DF-SS	G483-DF	G483-SF-SS	G483-SF	G483-HK	G483-5-SS	G483-5	G483-3ST	-
511	G511-DF-SS	G511-DF	G511-SF-SS	G511-SF	G511-HK	G511-5-SS	G511-5	G511-3ST	-
520	G520-DF-SS	G520-DF	G520-SF-SS	G520-SF	G520-HK	G520-5-SS	G520-5	G520-3ST	-
525	G525-DF-SS	G525-DF	G525-SF-SS	G525-SF	G525-HK	G525-5-SS	G525-5	G525-3ST	-
530	G530-DF-SS	G530-DF	G530-SF-SS	G530-SF	G530-HK	G530-5-SS	G530-5	G530-3ST	-
540	G540-DF-SS	G540-DF	G540-SF-SS	G540-SF	G540-HK	G540-5-SS	G540-5	G540-3ST	-

## Form-Flex® (HSH/FSH Series)

Kit Type	Repair Kits				Hardware Kit	Disc Pack		Rough Bore Hub	
Cplg Size	Double		Single (1)		Single (2)	SS	CS	STL	Cast Iron
	Disc Pack	Disc Pack	Disc Pack	Disc Pack					
22	D22-DF-SS	D22-DF	D22-SF-SS	D22-SF	D22-BNW	D22-5-SS	D22-5	D22-3ST	-
26	D26-DF-SS	D26-DF	D26-SF-SS	D26-SF	D26-BNW	D26-5-SS	D26-5	D26-3ST	-
31	D31-DF-SS	D31-DF	D31-SF-SS	D31-SF	D31-BNW	D31-5-SS	D31-5	D31-3ST	D31-3
35	D35-DF-SS	D35-DF	D35-SF-SS	D35-SF	D35-BNW	D35-5-SS	D35-5	D35-3ST	D35-3
37	D37-DF-SS	D37-DF	D37-SF-SS	D37-SF	D37-BNW	D37-5-SS	D37-5	D37-3ST	D37-3
42	D42-DF-SS	D42-DF	D42-SF-SS	D42-SF	D42-BNW	D42-5-SS	D42-5	D42-3ST	D42-3
45	D45-DF-SS	D45-DF	D45-SF-SS	D45-SF	D45-BNW	D45-5-SS	D45-5	D45-3ST	D45-3
50	D50-DF-SS	D50-DF	D50-SF-SS	D50-SF	D50-BNW	D50-5-SS	D50-5	D50-3ST	-
55	D55-DF-SS	D55-DF	D55-SF-SS	D55-SF	D55-BNW	D55-5-SS	D55-5	D55-3ST	-
60	D60-DF-SS	D60-DF	D60-SF-SS	D60-SF	D60-BNW	D60-5-SS	D60-5	D60-3ST	-
70	D70-DF-SS	D70-DF	D70-SF-SS	D70-SF	D70-BNW	D70-5-SS	D70-5	D70-3ST	-
75	D75-DF-SS	D75-DF	D75-SF-SS	D75-SF	D75-BNW	D75-5-SS	D75-5	D75-3ST	-
80	D80-DF-SS	D80-DF	D80-SF-SS	D80-SF	D80-BNW	D80-5-SS	D80-5	D80-3ST	-
85	D85-DF-SS	D85-DF	D85-SF-SS	D85-SF	D85-BNW	D85-5-SS	D85-5	D85-3ST	-
92	D92-DF-SS	D92-DF	D92-SF-SS	D92-SF	D92-BNW	D92-5-SS	D92-5	D92-3ST	-
92HT	D92HT-DF-SS	D92HT-DF	D92HT-SF-SS	D92HT-SF	D92HT-BNW	D92-5-SS	D92-5	D92HT-3ST	-

## Form-Flex® (GCH/GCF Series)

Kit Type	Repair Kits				Hardware Kit	Disc Pack		Rough Bore Hub
Cplg Size	Double		Single (1)		Single (2)	SS	CS	STL
	Disc Pack	Disc Pack	Disc Pack	Disc Pack				
340	G340-DF-SS	G340-DF	G340-SF-SS	G340-SF	G340-BN	G340-5-SS	G340-5	G340-3ST
412	G412-DF-SS	G412-DF	G412-SF-SS	G412-SF	G412-BN	G412-5-SS	G412-5	G412-3ST
424	G424-DF-SS	G424-DF	G424-SF-SS	G424-SF	G424-BN	G424-5-SS	G424-5	G424-3ST
456	G456-DF-SS	G456-DF	G456-SF-SS	G456-SF	G456-BN	G456-5-SS	G456-5	G456-3ST
511	G511-DF-SS	G511-DF	G511-SF-SS	G511-SF	G511-BN	G511-5-SS	G511-5	G511-3ST

# Form-Flex® A-Series Hub Options

TO ORDER A COMPLETE COUPLING, ORDER TWO HUBS OF ANY TYPE AND A COUPLING (SPACER) SUB ASSEMBLY FOR THE REQUIRED COUPLING TYPE. ALL DIMENSIONS SHOWN IN INCHES.

## AJ STANDARD HUBS - PROVIDED WITH STRAIGHT BORE AND KEYWAY - SOLID HUBS AVAILABLE FROM STOCK

Size	Max Bore		A	B	F	H	J	Std Set Screw Size
	(in)	(mm)						
05	0.875	22	2.65	0.25	1.00	1.30	0.38	#10-24 UNC
10	1.250	33	3.19	0.30	1.00	1.80	0.38	1/4-20 UNC
15	1.375	36	3.65	0.35	1.13	2.00	0.41	1/4-20 UNC
20	1.688	46	4.08	0.35	1.32	2.40	0.50	1/4-20 UNC
25	2.000	53	4.95	0.45	1.62	2.80	0.63	5/16-18 UNC
30	2.380	63	5.63	0.55	1.88	3.30	0.69	5/16-18 UNC
35	2.938	80	6.63	0.55	2.25	4.15	0.88	1/2-13 UNC

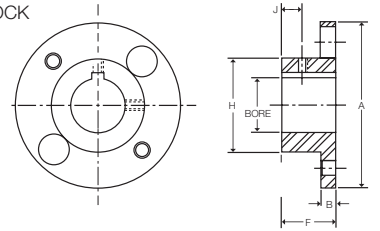

## AZ OVERSIZE BORE HUBS - PROVIDED WITH STRAIGHT BORE AND KEYWAY

Size	Max Bore		A	B	F	H	J	Std Set Screw Size
	(in)	(mm)						
05	1.188	30	2.65	0.25	1.00	1.88	0.38	#10-24 UNC
10	1.625	43	3.19	0.30	1.00	2.37	0.38	1/4-20 UNC
15	1.750	48	3.65	0.35	1.13	2.69	0.41	1/4-20 UNC
20	2.125	58	4.08	0.35	1.32	3.13	0.50	1/4-20 UNC
25	2.563	68	4.95	0.45	1.62	3.75	0.63	5/16-18 UNC
30	2.875	79	5.63	0.55	1.88	4.25	0.69	5/16-18 UNC
35	3.750	101	6.63	0.55	2.25	5.25	0.88	1/2-13 UNC

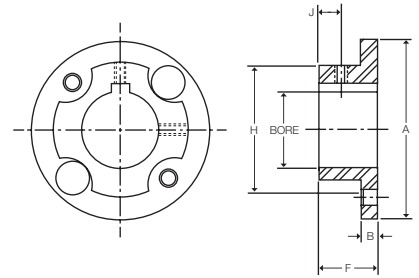

## QD BORED HUBS - MATERIAL CLASS A OR B ONLY

Size	Bush Size	Bush TQ. (lb-in)	Max Bore		B	C	F	H	Bolt Size
			(in)	(mm)					
15	JA	1000	1.250	28	1.17	1.00	0.56	2.00	#10-24 UNC
20	JA	1000	1.250	28	1.17	1.00	0.56	2.40	#10-24 UNC
25	SH	3500	1.688	35	1.50	1.25	0.75	2.80	1/4-20 UNC
30	SD	5000	2.000	42	2.06	1.81	1.25	3.30	1/4-20 UNC
35	SK	7000	2.625	55	2.19	1.87	1.25	4.15	5/16-18 UNC
40	SF	11000	2.938	65	2.38	2.06	1.37	4.65	3/8-16 UNC

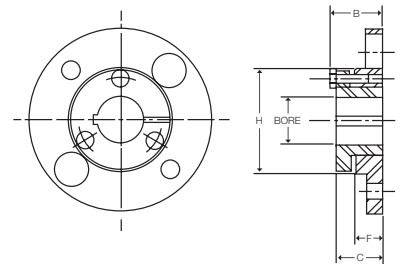

## HUBS FOR TAPER LOCK BUSHINGS - AVAILABLE MTO ONLY

Size	Regular Mount					Reverse Mount				
	Bush Size	Bush TQ. (lb-in)	Max Bore		F (in)	Bush Size	Bush TQ. (lb-in)	Max Bore		F (in)
			(in)	(mm)				(in)	(mm)	
15	N/A	-	-	-	-	1108	1300	1.12	25	0.87
20	1108	1300	1.12	25	0.87	1215	3550	1.25	32	1.50
25	1215	3550	1.25	32	1.50	1310	3850	1.37	35	1.00
30	1310	3850	1.37	35	1.00	1615	4300	1.62	42	1.50
35	2012	7150	2.00	48	1.25	2517	11600	2.50	65	1.75
40	2525	11300	2.50	65	2.50	2525	11300	2.50	65	2.50

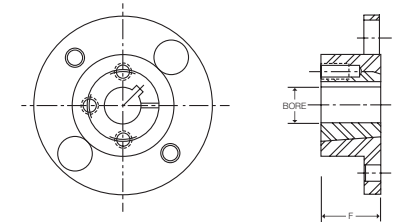

## AC/AD CLAMPING HUBS - AC HUBS PROVIDED WITHOUT KEYWAY - AD HUBS PROVIDED WITH KEYWAY - MATERIAL CLASS A OR B ONLY

Size	Max Bore				A	F	G	H	Clamp Screw Size
	AC		AD						
	(in)	(mm)	(in)	(mm)					
5	1.00	25	0.87	20	2.65	1.13	0.50	2.06	1/4-20 UNC
10	1.00	25	0.87	20	3.19	1.18	0.50	2.06	1/4-20 UNC
	1.50	38	1.25	30		1.36	0.69	2.75	5/16-18 UNC
15	1.00	25	0.87	20	3.65	1.27	0.50	2.06	1/4-20 UNC
	1.75	44	1.37	24		1.46	0.69	3.00	5/16-18 UNC
20	1.31	33	1.00	24	4.08	1.32	0.55	2.38	1/4-20 UNC
	2.13	53	1.62	42		1.52	0.75	3.50	3/8-16 UNC
25	2.13	53	1.62	42	4.95	1.62	0.64	3.50	5/16-18 UNC
	2.50	63	1.87	50		1.86	0.88	4.00	3/8-16 UNC

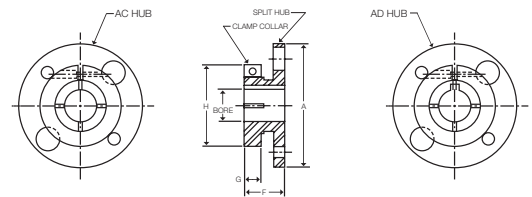

## AL LOCK ELEMENT HUBS - THESE HUBS USE RINGFEDER TAPERED LOCKING ELEMENTS - MATERIAL CLASS A OR B ONLY

Size	Hub Type	Bore Size				B	F	G	Screw Size
		Min		Max					
		(in)	(mm)	(in)	(mm)				
5	AJ	0.24	6	0.51	13	1.00	1.32	0.32	#10-32 UNF
	AZ	0.55	14	0.75	19	1.00	1.42	0.42	1/4-28 UNF
10	AJ	0.47	12	0.71	18	1.00	1.42	0.42	1/4-28 UNF
	AZ	0.75	19	1.18	30	1.00	1.42	0.42	1/4-28 UNF
15	AJ	0.47	12	0.87	22	1.13	1.55	0.42	1/4-28 UNF
	AZ	0.94	24	1.38	35	1.13	1.55	0.42	1/4-28 UNF
20	AJ	0.87	22	1.18	30	1.32	1.78	0.42	1/4-28 UNF
	AZ	1.26	32	1.65	42	1.32	1.83	0.51	5/16-24 UNF
25	AJ	0.87	22	1.26	32	1.63	2.05	0.42	1/4-28 UNF
	AZ	1.38	35	1.97	50	1.63	2.23	0.60	3/8-24 UNF

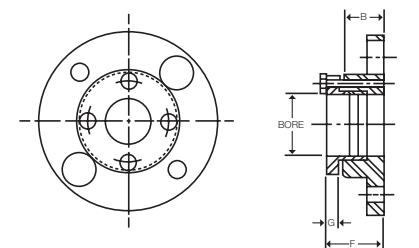

NOTE: AC and AL Hubs do not carry full torque capacity. Please consult engineering.



# Form-Flex® G-Series and Torsiflex-i Hub Options

## CLAMP HUB

PROVIDED WITH STRAIGHT BORE AND KEYWAY

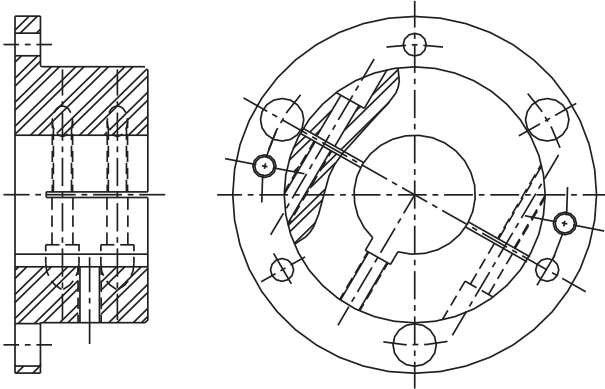

## EXTERNAL LOCKING ELEMENT

USED WITH KEYLESS SHAFTS

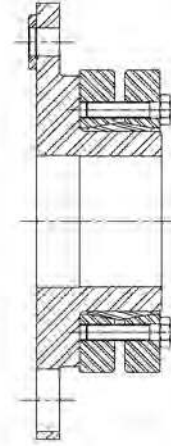

## INTERNAL LOCKING ELEMENT

USED WITH KEYLESS SHAFTS

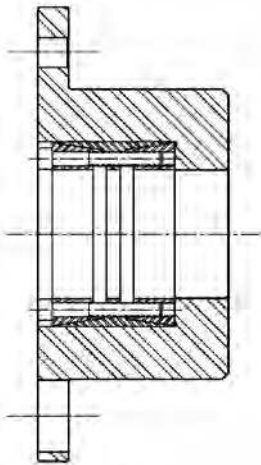

## TAPER BORE WITH HYDRAULIC REMOVAL

USED WITH KEYLESS TAPERED SHAFTS

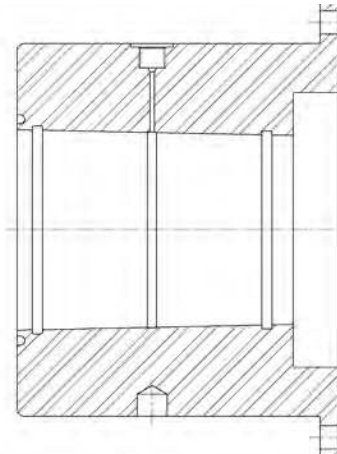

## SPECIAL FLANGE ADAPTERS

DESIGNED TO MATE WITH ANY CUSTOM FLANGE

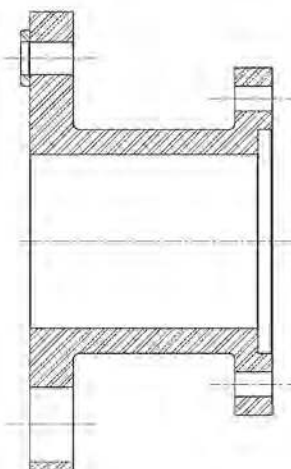

## OVERSIZE HUB DESIGN

FOR INCREASED BORE CAPACITY

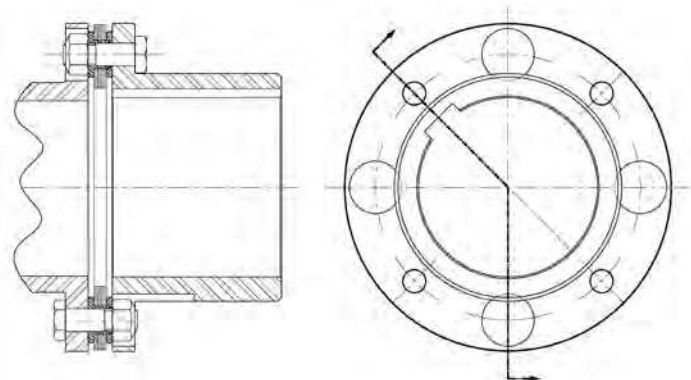

# Coupling Design Options and Special Applications

## ELECTRICAL INSULATION SPACER WITH SPLINE BORE AND EXTERNAL LOCKING ELEMENT

Two piece spacer design with e-glass composite tube separating the steel halves.

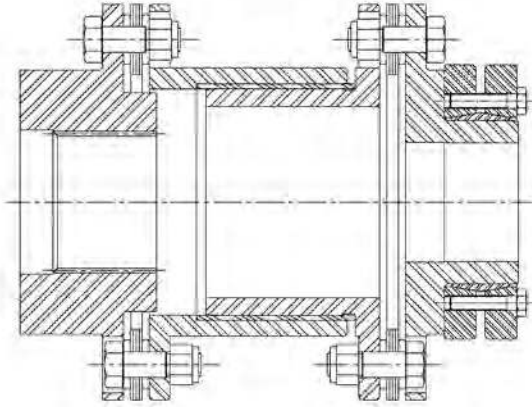

## INERTIA RING ADDED TO TORSIONALLY TUNE COMPRESSOR SYSTEM

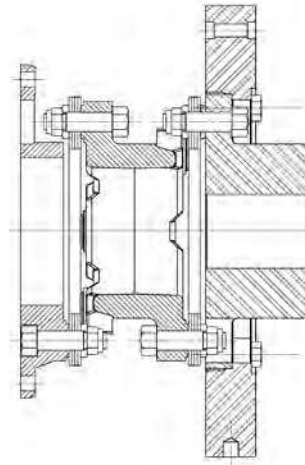

## MODIFIED TORSIFLEX-i DESIGN WITH FLANGE TO FLANGE MOUNTING

Flanges designed to bolt to customer pilot and bolt pattern for test stand application.

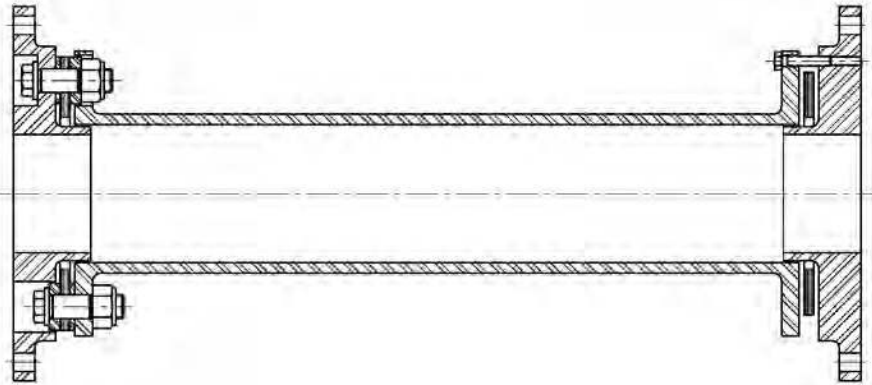

## FLOATING SHAFT COUPLING WITH OVER SIZED TUBE FOR INCREASED STIFFNESS AND CRITICAL SPEED WITH CUSTOM FLANGE ADAPTER

Special features include oversize steel tube welded to bolted adapters for easy assembly, motor hub with integral brake disc, custom flange.

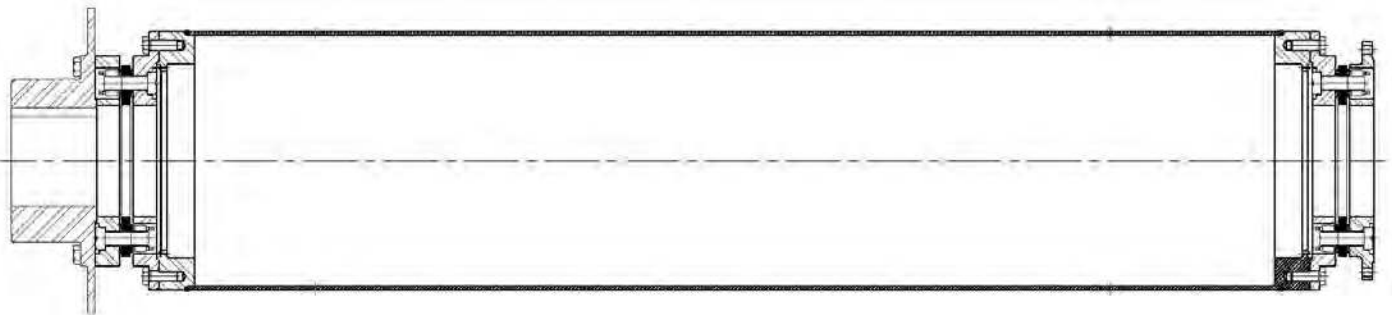

# Coupling Design Options and Special Applications

## MULTI-SHAFT ASSEMBLY FOR VERICAL PUMPING STATIONS USING COMPOSITE TUBE TECHNOLOGY

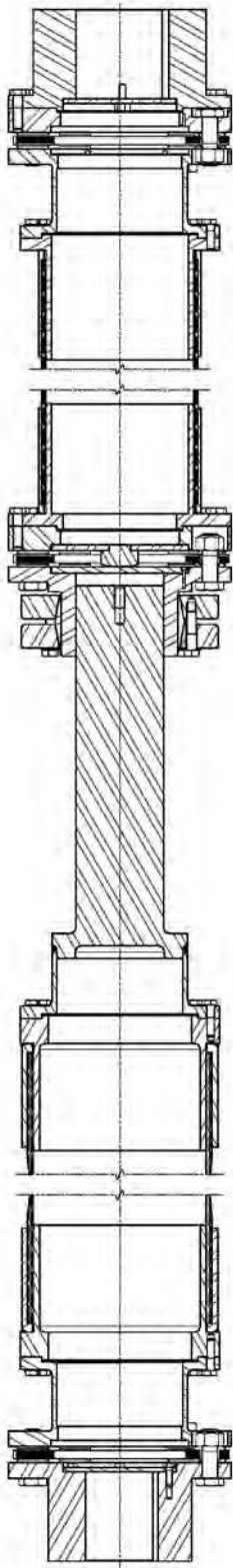

# Disc, Bolt Thread and Tool Size Identification Chart

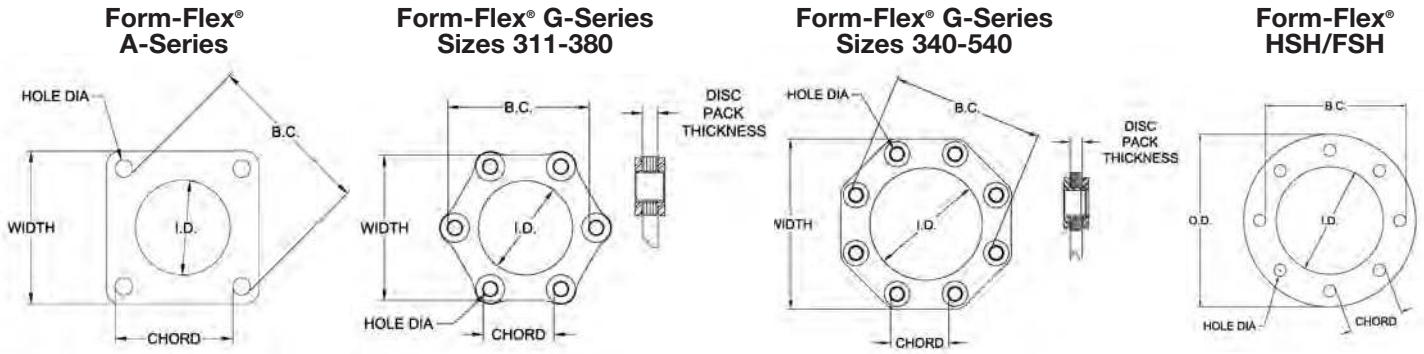

Coupling Series	Disc Size	Disc Dimensions (in)						Bolt				Nut	
		Width/OD	ID	Hole Dia.	B.C. Dia.	Chord	Disc Pack Thickness	Thread Dia. (in)	Thread Pitch	Thread Designation	HEX WAF (in)	HEX WAF (in)	Wrench Torque (lb-ft)
Form-Flex A-Series	5	1.83	1.00	0.25	1.88	1.31	0.06	0.250	28	1/4-28	0.438	0.438	8
	10	2.19	1.17	0.25	2.37	1.69	0.09	0.250	28	1/4-28	0.438	0.438	8
	15	2.54	1.28	0.31	2.69	1.88	0.12	0.313	24	5/16-24	0.500	0.500	17
	20	2.84	1.65	0.31	3.12	2.19	0.14	0.313	24	5/16-24	0.500	0.500	17
	25	3.52	1.78	0.44	3.75	2.63	0.15	0.438	20	7/16-20	0.625	0.625	40
	30	4.01	2.01	0.50	4.25	3.00	0.21	0.500	20	1/2-20	0.750	0.750	58
Form-Flex G-Series	35	4.71	2.71	0.50	5.25	3.69	0.27	0.500	20	1/2-20	0.750	0.750	58
	311	4.78	3.58	0.39	4.86	2.44	0.20	0.313	24	5/16-24	0.500	0.500	22
	321	5.38	3.72	0.51	5.25	2.63	0.25	0.438	20	7/16-20	0.625	0.688	55
	332	6.00	3.87	0.64	5.81	2.88	0.32	0.563	18	9/16-18	0.813	0.813	120
	346	6.93	4.75	0.64	6.81	3.38	0.32	0.563	18	9/16-18	0.813	0.813	120
	380	8.05	5.06	0.87	7.48	3.75	0.39	0.750	16	3/4-16	1.125	1.125	288
	340	7.50	4.91	0.63	6.75	2.56	0.24	0.500	20	1/2-20	0.875	0.875	75
	412	9.61	6.10	1.00	8.50	3.25	0.39	0.750	16	3/4-16	1.250	1.250	250
	419	11.01	7.00	1.14	9.75	3.75	0.50	1.000	14	1-14	1.625	1.625	585
	424	13.49	8.89	1.20	12.01	4.63	0.50	1.000	14	1-14	1.625	1.625	585
	444	15.06	9.60	1.44	13.19	5.06	0.57	1.125	12	1 1/8-12	1.813	1.813	840
	456	16.57	10.66	1.56	14.57	5.56	0.69	1.250	12	1 1/4-12	2.000	2.000	1,095
	483	17.90	11.54	1.67	15.75	6.00	0.77	1.375	12	1 3/8-12	2.188	2.188	1,240
	511	20.35	13.50	1.74	18.06	6.94	0.93	1.500	12	1 1/2-12	2.375	2.364	1,640
520	23.19	14.59	2.21	20.20	7.75	1.14	1.875	12	1 7/8-12	3.000	0.438	108	
525	24.95	15.64	2.35	21.70	8.31	1.20	2.000	12	2-12	3.125	0.438	124	
530	26.12	16.34	2.50	22.70	8.69	1.26	2.125	12	2 1/8-12	3.375	0.438	141	
540	31.21	21.15	2.65	28.05	10.75	1.58	2.250	10	2 1/4-12	3.750	0.563	196	
Form-Flex HSH/FSH	22	5.625	3.855	0.3275	4.7505	1.81	0.18	0.313	24	5/16-24	0.500	0.500	25
	26	6.565	4.400	0.4055	5.5010	2.13	0.22	0.375	24	3/8-24	0.563	0.563	30
	31	7.750	5.250	0.4680	6.5000	2.50	0.25	0.438	20	7/16-20	0.625	0.625	40
	35	8.625	5.750	0.5315	7.2500	2.75	0.29	0.500	20	1/2-20	0.813	0.750	70
	37	9.625	6.312	0.6265	8.0000	3.06	0.33	0.563	18	9/16-18	0.938	0.875	95
	42	10.500	6.750	0.6885	8.6250	3.31	0.31	0.625	18	5/8-18	1.063	0.938	125
	45	11.250	7.250	0.7505	9.2500	3.56	0.38	0.625	18	5/8-18	1.125	1.063	150
	50	12.813	8.500	0.8755	10.5000	4.00	0.47	0.750	16	3/4-16	1.250	1.250	210
	55	14.375	9.000	1.0005	11.7500	4.50	0.54	0.875	14	7/8-14	1.375	1.438	320
	60	15.938	9.938	1.1270	13.0000	5.00	0.59	1.000	14	1-1/4	1.625	1.625	450
	70	18.125	11.125	1.3120	14.7500	5.63	0.78	1.125	12	1 1/8-12	1.750	1.813	575
	75	19.720	12.000	1.4380	16.0000	6.13	0.80	1.250	12	1 1/4-12	1.938	2.000	830
	80	21.438	13.125	1.5630	17.3760	6.63	0.81	1.375	12	1 3/8-12	2.125	2.188	1000
	85	22.875	14.000	1.7505	18.5000	7.06	0.88	1.500	12	1 1/2-12	2.500	2.375	1400
	92	24.875	15.000	1.8760	20.0000	7.63	1.01	1.500	12	1 1/2-12	2.500	2.375	1400
	92HT	24.875	15.000	1.8760	20.0000	7.63	1.01	1.750	12	1 3/4-12	2.500	2.750	2400

# Application Data Sheet

Project Ref: \_\_\_\_\_  
 Company: \_\_\_\_\_ Date: \_\_\_\_\_  
 Contact: \_\_\_\_\_ Email: \_\_\_\_\_  
 Replacing: \_\_\_\_\_ Phone #: \_\_\_\_\_

<b>SECTION I - DRIVER</b>	Electric Motor <input type="checkbox"/> ; Engine <input type="checkbox"/> - # Cylinders _____ ; Turbine <input type="checkbox"/> ; Other _____
HP: _____	KW: _____ Normal Torque: _____ Lb-in[ ] Nm[ ]
Rated Speed: _____	Max Torque: _____ Lb-in[ ] Nm[ ]
Operating Speed: _____	Breakdown Torque: _____ Lb-in[ ] Nm[ ]

<b>SECTION II - DRIVEN</b>	Description: _____
Load Application: Non-Pulsating <input type="checkbox"/> Medium Pulsating <input type="checkbox"/> Heavy Pulsating <input type="checkbox"/> Smooth <input type="checkbox"/> Light Shock <input type="checkbox"/> Heavy Shock <input type="checkbox"/>	

<b>SECTION III - COUPLING APPLICATION</b>	Min Service Factor: _____
Temperature Range: _____ to _____ °C <input type="checkbox"/> or °F <input type="checkbox"/>	Hydraulic Removal: Yes <input type="checkbox"/> No <input type="checkbox"/>
Specification: API671 <input type="checkbox"/> Edition _____ ; API610 <input type="checkbox"/> Edition _____ ; Other _____	
Balance: Cplg <input type="checkbox"/> Hubs <input type="checkbox"/> Spacer <input type="checkbox"/>	Balance Specification _____

<b>SECTION IV - DIMENSIONAL DATA</b>	Distance Between Shaft Ends (DBSE): _____ IN <input type="checkbox"/> MM <input type="checkbox"/>
Taper Shaft & Keyway Data	
Driver	Driven
Shaft Dia (Straight): _____	_____
Shaft Dia L.E. (Taper): _____	_____
Taper Ratio _____	_____
Keyway Size: Width _____ Depth _____	Width _____ Depth _____
KW Depth Across Bore: _____	_____

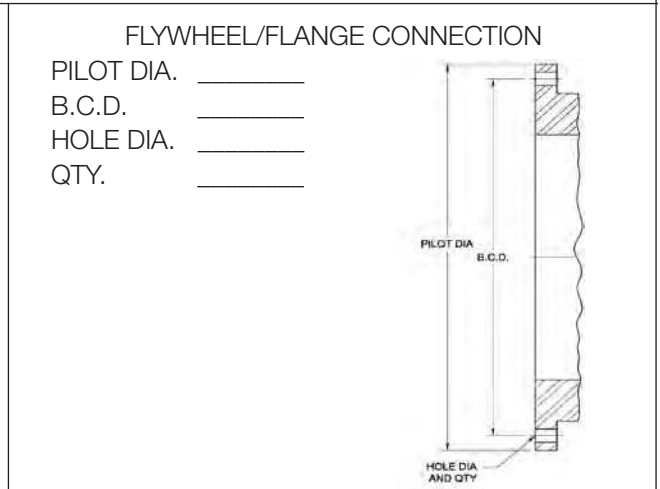
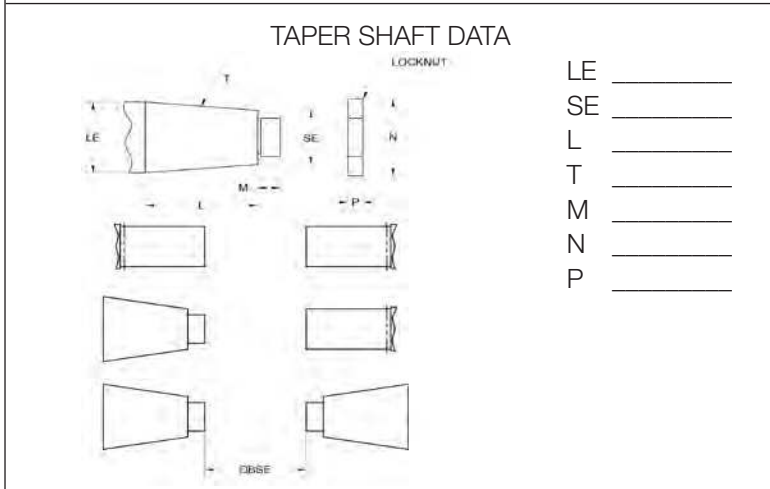

**STANDARD ADAPTER SIZES**

Size	O.D. (in)	SAE Bolting			HD Bolting		
		P.C.D. (in)	Hole Qty.	Hole Size (in)	P.C.D. (in)	Hole Qty.	Hole Size (in)
10	10.375	9.625	6	0.406	9.500	8	0.469
12	12.375	11.625	8	0.406	11.500	8	0.531
14	13.875	13.125	8	0.406	12.500	8	0.656
18	18.375	17.250	8	0.531	16.750	8	0.781
20	20.375	19.250	8	0.531	18.500	8	0.906
22	22.500	21.375	6	0.656	20.500	8	1.031
26	26.500	25.250	12	0.656	24.500	12	1.031
28	28.875	27.250	12	0.781	26.875	12	1.031

# Application Data Sheet

---

Additional Comments: \_\_\_\_\_  
\_\_\_\_\_  
\_\_\_\_\_  
\_\_\_\_\_  
\_\_\_\_\_

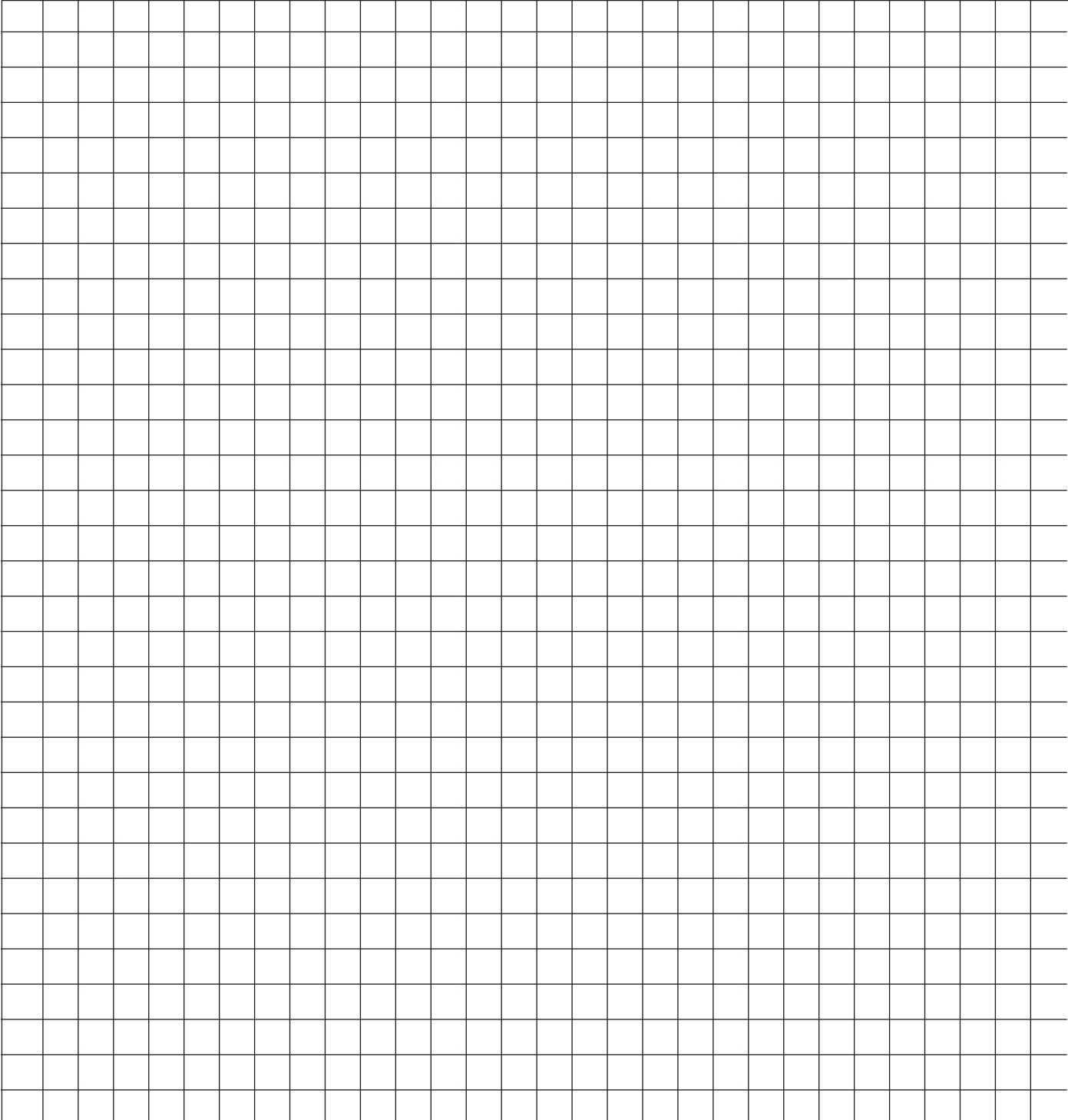

Sketch Area



# Rigid Couplings

Ribbed Type Compression Couplings are recommended for emergency and regular service on heavily loaded shafts.

These couplings are bored true to shaft size, and the halves are separated during boring operation to allow for clamping when halves are drawn together. Bolt heads and nuts are protected by flanges. End flanges are faced square with bore, and outer diameters are turned.

To facilitate the use of V-belt drives, sufficient space may be left between shaft ends when mounting the coupling to permit easy replacement of belts.



**RIBBED  
COMPRESSION  
NO. 257**

**F7**

Product No.	Shaft Size	Max. RPM	Approx. Diam.	Length	BOLTS			Weight Lbs.
					No.	Size	Wrench (1) Torque ft.-lb.	
2571316	1-3/16	4630	4-1/8	5-3/8	6	3/8	19	11
257114	1-1/4	4630	4-1/8	5-3/8	6	3/8	19	11
2571716	1-7/16	4070	4-11/16	6-1/8	6	1/2	45	18
257112	1-1/2	4070	4-11/16	6-1/8	6	1/2	45	18
25711116	1-11/16	3820	5	6-3/4	6	1/2	45	20
257134	1-3/4	3820	5	6-3/4	6	1/2	45	20
25711516	1-15/16	3250	5-7/8	8	6	5/8	93	34
2572	2	3250	5-7/8	8	6	5/8	93	33
2572316	2-3/16	3050	6-1/4	8-3/4	6	5/8	93	38
257214	2-1/4	3050	6-1/4	8-3/4	6	5/8	93	38
2572716	2-7/16	2680	7-1/8	9-5/8	6	3/4	150	57
257212	2-1/2	2680	7-1/8	9-5/8	6	3/4	150	54
25721116	2-11/16	2610	7-5/16	10-5/8	6	3/4	150	62
25721516	2-15/16	2210	8-5/8	11-5/8	8	3/4	150	95
2573	3	2210	8-5/8	11-5/8	8	3/4	150	95
2573316	3-3/16	2100	9-1/16	12-3/4	8	3/4	150	126
2573716	3-7/16	1920	9-15/16	13-5/8	8	7/8	202	157
257312	3-1/2	1920	9-15/16	13-5/8	8	7/8	202	157
25731516	3-15/16	1830	10-7/16	14-5/8	8	7/8	202	171
2574716	4-7/16	1600	11-7/8	16-1/2	8	1	300	273
25741516	4-15/16	1390	13-11/16	18-1/8	8	1-1/8	474	395

NOTE: Capacity of Coupling exceeds capacity of shaft based on 6000 PSI Shaft Stress.

(1) Do not lubricate CAP Screws. Other shaft sizes available on a MTO Basis.

Coupling may require balancing to reduce vibration when operating within these speeds.



# Rigid Couplings

## Dimensions

This coupling is designed to provide a simple method of rigidly connecting two pieces of shafting. The standard Sure-Grip tapered bushing is used, one on each shaft, to securely clamp the two shafts together. The precision tapered fit lines up the two shafts. No press or shrink fits are necessary.



**SURE-GRIP RIGID NO.44**

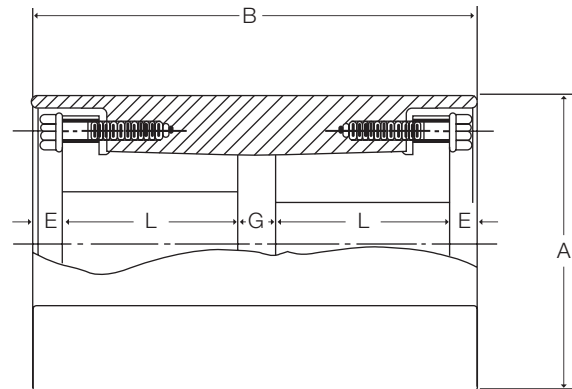

Product No.	Max. RPM	Maximum Bore		Bushing †	DIMENSIONS					Weight Including Bushing
		Light (1) Loads	Heavy (2) Loads		A	B	E	G	L	
44SD	6200	1-13/16	1-7/16	SD	4	4-5/8	3/8	1/4	1-13/16	11
44SF	4500	2-3/8	1-7/8	SF	5-1/2	5-1/4	1/2	1/4	2	22
44E	3600	2-15/16	2-1/4	E	6-7/8	6-3/4	5/8	1/4	2-5/8	54
44J	3000	3-13/16	3	J	8-1/4	11	3/4	1/2	4-1/2	122
44M	2450	4-3/4	3-11/16	M*	10	16	1	1/2	6-3/4	270

† Dimensions for Sure-Grip bushings are given on page A1 – 3.

\* Bushing M is not stocked with drilled holes for the above type mounting and will be made-to-order.

(1) Max Shaft Stress < 8500 psi.

(2) Max Shaft Stress < 4000 psi.

$$\text{Axial Thrust Capacity} = \frac{\text{Bushings Torque Capacity}}{\text{Radius of Shaft}}$$

---

---

---

---

---

---

---

---

---

---

---

---

---

---

---

---

---

---

---

---

---

---

---

---

---

---

# ALTRA COUPLINGS

**Offers the Largest Selection of Industrial Couplings Available from a Single Source...Worldwide**

The industry-leading brands of Altra Couplings, **TB Wood's**, **Huco Dynatork**, **Bibby Turboflex**, **Ameridrives Power Transmission**, **Ameridrives Couplings** and **Lamiflex Couplings**, have been providing innovative coupling solutions to meet the requirements for a broad variety of applications spanning many industries. Highly engineered Altra coupling products represent the latest in coupling technology, featuring superior design and exceptional quality to ensure long-lasting performance in all types of environments.

[www.AltraCouplings.com](http://www.AltraCouplings.com)



**Coupling Guards & Bearing Isolators**  
- Lamiflex Couplings



**Elastomeric Couplings**  
- TB Wood's  
- Bibby Turboflex



**Elastomeric Couplings**  
- Bibby Turboflex  
- Ameridrives Couplings



**Gear Spindles**  
- Ameridrives Couplings



**Universal Joints**  
- Ameridrives Power Transmission



**Torque Limiters**  
- Bibby Turboflex



**General Purpose Disc Couplings**  
- TB Wood's  
- Ameridrives Couplings  
- Bibby Turboflex  
- Lamiflex Couplings



**High Performance Disc & Diaphragm Couplings**  
- Ameridrives Power Transmission  
- Bibby Turboflex  
- Lamiflex Couplings



**Precision Couplings**  
- Huco Dynatork



**Locking Devices**  
- Ameridrives Couplings

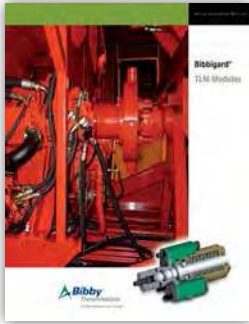

P-1942-BB

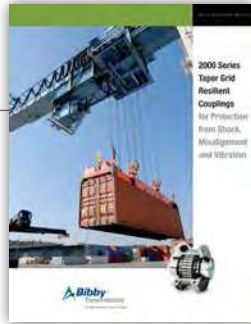

P-1939-BB



P-1940-BB

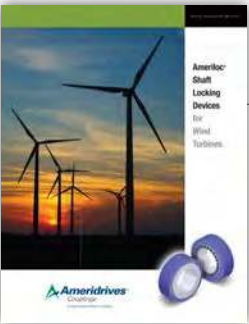

P-1967-AC

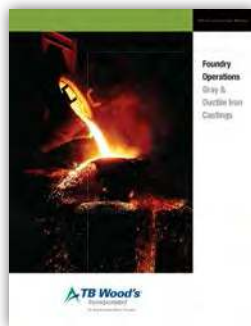

P-1791-TBW



P-1919-TBW

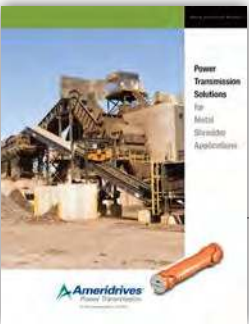

P-1902-AP

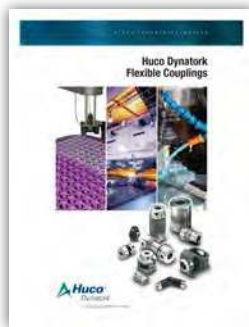

P-7293-HD



# Altra Literature

To download the above literature or any other literature please visit our Literature Portal.

[www.AltraLiterature.com](http://www.AltraLiterature.com)



All Customer Service phone numbers shown in bold

## Electromagnetic Clutches and Brakes

### Warner Electric

*Electromagnetic Clutches and Brakes*

New Hartford, CT - USA  
1-800-825-6544

*For application assistance:*  
1-800-825-9050

St Barthelemy d'Anjou, France  
+33 (0) 2 41 21 24 24

*Precision Electric Coils and Electromagnetic Clutches and Brakes*

Columbia City, IN - USA  
1-260-244-6183

### Matrix International

*Electromagnetic Clutches and Brakes, Pressure Operated Clutches and Brakes*

Brechin, Scotland  
+44 (0) 1356 602000

New Hartford, CT - USA  
1-800-825-6544

### Inertia Dynamics

*Spring Set Brakes; Power On and Wrap Spring Clutch/Brakes*

New Hartford, CT - USA  
1-800-800-6445

## Linear Products

### Warner Linear

*Linear Actuators*

Belvidere, IL - USA  
1-800-825-6544

*For application assistance:*  
1-800-825-9050

St Barthelemy d'Anjou, France  
+33 (0) 2 41 21 24 24

## Couplings

### Ameridrives Couplings

*Mill Spindles, Ameriflex, Ameridisc*

Erie, PA - USA  
1-814-480-5000

*Gear Couplings*

San Marcos, TX - USA  
1-800-458-0887

### Bibby Turboflex

*Disc, Gear, Grid Couplings, Overload Clutches*

Dewsbury, England  
+44 (0) 1924 460801

Boksburg, South Africa  
+27 11 918 4270

### TB Wood's

*Elastomeric Couplings*

Chambersburg, PA - USA  
1-888-829-6637 – Press #5

*For application assistance:*  
1-888-829-6637 – Press #7

*General Purpose Disc Couplings*

San Marcos, TX - USA  
1-888-449-9439

### Ameridrives Power Transmission

*Universal Joints, Drive Shafts, Mill Gear Couplings*

Green Bay, WI - USA  
1-920-593-2444

### Huco Dynatork

*Precision Couplings and Air Motors*

Hertford, England  
+44 (0) 1992 501900

Chambersburg, PA - USA  
1-888-829-6637

### Lamiflex Couplings

*Flexible Couplings, Bearing Isolators, and Coupling Guards*

São Paulo, SP - Brasil  
+55-11-5679-6533

## Heavy Duty Clutches and Brakes

### Wichita Clutch

*Pneumatic Clutches and Brakes*

Wichita Falls, TX - USA  
1-800-964-3262

Bedford, England  
+44 (0) 1234 350311

### Twiflex Limited

*Caliper Brakes and Thrusters*

Twickenham, England  
+44 (0) 20 8894 1161

### Industrial Clutch

*Pneumatic and Oil Immersed Clutches and Brakes*

Waukesha, WI - USA  
1-262-547-3357

## Gearing

### Boston Gear

*Enclosed and Open Gearing, Electrical and Mechanical P.T. Components*

Charlotte, NC - USA  
1-800-825-6544

*For application assistance:*  
1-800-816-5608

### Bauer Gear Motor

*Geared Motors*

Esslingen, Germany  
+49 (711) 3518 0

Somerset, NJ - USA  
1-732-469-8770

### Nuttall Gear and Delroyd Worm Gear

*Worm Gear and Helical Speed Reducers*

Niagara Falls, NY - USA  
1-716-298-4100

## Overrunning Clutches

### Formsprag Clutch

*Overrunning Clutches and Holdbacks*

Warren, MI - USA  
1-800-348-0881 – Press #1

*For application assistance:*  
1-800-348-0881 – Press #2

### Marland Clutch

*Roller Ramp and Sprag Type Overrunning Clutches and Backstops*

South Beloit, IL - USA  
1-800-216-3515

### Stieber Clutch

*Overrunning Clutches and Holdbacks*

Heidelberg, Germany  
+49 (0) 6221 30 47 0

## Belted Drives and Sheaves

### TB Wood's

*Belted Drives*

Chambersburg, PA - USA  
1-888-829-6637 – Press #5

*For application assistance:*  
1-888-829-6637 – Press #7

## Engineered Bearing Assemblies

### Kilian Manufacturing

*Engineered Bearing Assemblies*

Syracuse, NY - USA  
1-315-432-0700

For information concerning our sales offices in Asia Pacific check our website  
[www.altramotion.com.cn](http://www.altramotion.com.cn)



[www.tbwoods.com](http://www.tbwoods.com)

440 North Fifth Avenue  
Chambersburg, PA 17201 - USA  
888-829-6637 • 717-264-7161  
Fax: 717-264-6427