

Schnitt A-A section

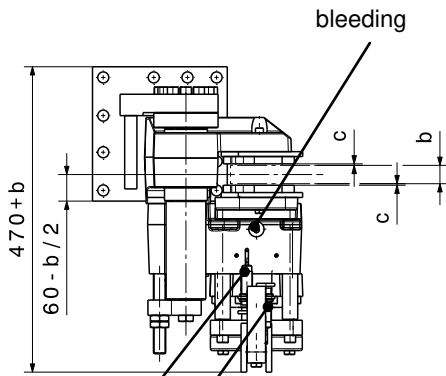
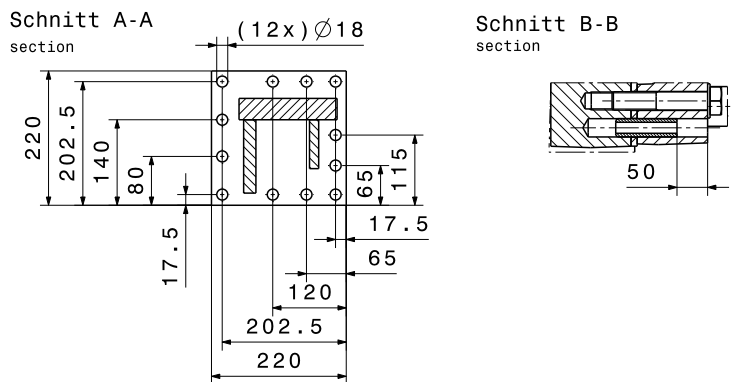

optional limit switch:
Belagverschleiß

optional limit switch:
brake open/ close

Mounting Studs				
Type SHI FC	101 – 103	104 – 105	106 – 107	
n	quantity	12	12	12
	size, grade	M16, 12.9	M16, 12.9	M16, 12.9
M_A	fastening torque in Nm	355 at $\mu = 0,14$	355 at $\mu = 0,14$	355 at $\mu = 0,14$
Linings				
	material	Sinter		
	friction coefficient*1	μ 0,4		
*1 average friction coefficient with standard material combination and a circumferential speed up to 15 m/s				

SHI-Type SHI 100 FC		1	2	3	4	5	6	7	
Clamping Force F_A									
F_A	with airgap $c = 1,0$ mm	kN	28,0	43,7	52,2	68,7	77,0	98,0	115,0
F_A	with airgap $c = 1,5$ mm	kN	27,0	41,3	48,8	62,7	74,4	88,0	94,0
Torque Calculation									
M_{Br}	braking torque	Nm	$2 \times F_A \times \mu \times (d/2-60)$						
Hydraulic									
P_L	release pressure	bar	35	50	60	80	95	145	175
P_{max}	max. pressure	bar	110	110	110	110	150	175	205
V_{max}	volume at $c = 1,5$ mm	ltr	0,034						
Brake Disc									
b	disc thickness	mm	$20 \leq b \leq 40$						
d	disc- ϕ	mm	$650 \leq d \leq 3000$						
d_1	max. hub-/ drum- ϕ	mm	$d-280$ mm						
Dimensions									
$L \times B \times H = 343 \times (470+b) \times 570$ mm									
max. weight: 180 kg									

When ordering please advise: right hand version, as shown; left hand version, mirror inverted!

Änderungen vorbehalten

SIBRE Siegerland-Bremsen GmbH – Auf der Stücke 1-5 – D-35708 Haiger, Germany
Tel.: +49 2773 94000 – Fax: +49 2773 9400-10 – e-mail: info@sibre.de – www.sibre.de