

hydraulic connection G 1/2"

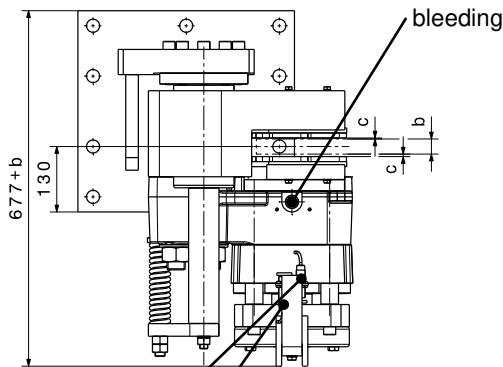

optional limit switch:  
lining wear

optional limit switch:  
brake open / close

Mounting Studs			
n	quantity		10
	size, grade		M24, 8.8
M <sub>A</sub>	fastening torque	Nm	710 at μ=0,14
Linings			
	material		sinter
	friction coefficient *		0,4

\*average friction coefficient with standard material combination and a circumferential speed up to 15 m/s

SHI-Type		231 FC	232 FC
<b>Clamping Force F<sub>A</sub></b>			
F <sub>A</sub>	with airgap c = 1 mm	kN	240
F <sub>A</sub>	with airgap c = 1,5 mm	kN	225
<b>Torque Calculation</b>			
M <sub>Br</sub>	braking torque Nm	2 x F <sub>A</sub> x μ x (d/2-95)	
<b>Hydraulic</b>			
P <sub>L</sub>	release pressure	bar	130
P <sub>max</sub>	max. pressure	bar	175
V <sub>max</sub>	volume at c= 1,5 mm	ltr	0,076
<b>Brake Discs</b>			
b	disc thickness	mm	20 ≤ b ≤ 40
d	disc-Ø	mm	900 ≤ d ≤ 2400
d <sub>1</sub>	max. hub- / drum-Ø	mm	d - 440
<b>Dimensions</b>			
L x W x H = 545 x (677+b) x 910 mm			
max. weight: 660 kg			

When ordering please advise: right hand version, as shown;  
left hand version, mirror inverted!