

hydraulic connection G 1/2"

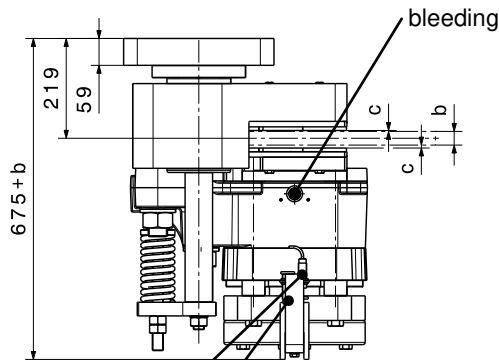

optional limit switch:
lining wear

optional limit switch:
brake open / close

Mounting Studs			
n	quantity		14
	size, grade		M30, 10.9
M _A	fastening torque	Nm	2000 at μ=0,14
Linings			
	material		sinter
	friction coefficient *		0,4

*average friction coefficient with standard material combination and a circumferential speed up to 15 m/s

SHI-Type		281 FC	282 FC
Clamping Force F_A			
F _A	with airgap c = 1 mm	kN	425
F _A	with airgap c = 1,5 mm	kN	395
Torque Calculation			
M _{Br}	braking torque Nm	2 x F _A x μ x (d/2-112.5)	
Hydraulic			
P _L	release pressure	bar	135
P _{max}	max. pressure	bar	175
V _{max}	volume at c= 1,5 mm	ltr	0,09
Brake Discs			
b	disc thickness	mm	30 ≤ b ≤ 40
d	disc-Ø	mm	1600 ≤ d ≤ 5000
d ₁	max. hub- / drum-Ø	mm	d - 545
Dimensions			
L x W x H = 535 x (675+b) x 1030 mm			
max. weight: 965 kg			

When ordering please advise: right hand version, as shown;
left hand version, mirror inverted!