

- Ø D1 = theoretical friction diameter in mm
- Ø D2 = outer brake disc diameter in mm
- Ø D3 = max. coupling or hub diameter in mm
- B = brake disc width in mm, standard = 20 mm, other widths on request

standard : - incl. lining wear compensator
 - incl. synchronization linkage
 - organic linings
 - available in right hand and left hand version

optional : - sinter linings
 - manual release
 - limit switches (brake open/closed, wear, man.release)

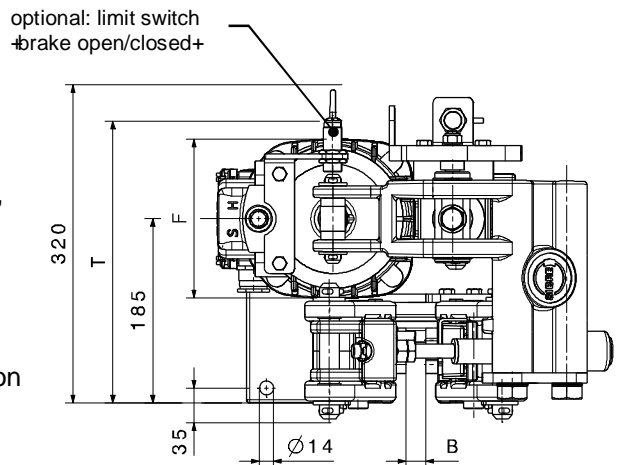

disc brake shown with ED30/5 in right hand version

				EMG-thruster Type								
weight w/o thruster: ~56kg				EB 120-40			EB 220-50			EB 300-50		
				ED12/4			ED23/5			ED30/5		
braking torque M_{Br} in Nm at $\mu=0,35$; adjustable from / to												
D2	D1	D3	R1	F=110	C=190	T=240	F=162	C=240	T=283	F=160	C=215	T=270
250	200	75	61	30 / 110			100 / 210			100 / 300		
280	230	105	76	30 / 125			130 / 240			130 / 350		
315	260	140	93	40 / 140			150 / 270			150 / 400		
355	300	180	113	40 / 160			180 / 310			180 / 460		
400	345	220	135	50 / 190			210 / 360			210 / 530		

Alterations reserved

SIBRE Siegerland-Bremsen GmbH . Auf der Stücke 1-5 . D-35708 Haiger, Germany
 Tel.: +49 2773 94000 . Fax: +49 2773 9400-10 . e-mail: info@sibre.de . www.sibre.de