

Industrial Disc Brakes



 **Twiflex**[®]
Limited

An Altra Industrial Motion Company

Twiflex Limited... Leaders In Advanced Braking Technology

Twiflex Limited, with headquarters in Twickenham, England, specialises in the design, manufacture and supply of Advanced Braking Technology for industrial applications. With extensive in-house facilities, Twiflex enjoys a global reputation for quality.

Founded in 1946, Twiflex has produced more than half a million brake units, frequently for safety-critical duty, for applications around the world. From textile machines in the north of England to the world's deepest mine shaft in South Africa, Twiflex brakes are specified by engineers and system designers in every type of industry.

From defining complete braking systems to identifying spare components, the catalogue provides useful guidance. An approximate brake selection may be made by assessing the data shown, however, it is always recommended to contact a Twiflex representative for a more detailed proposal.

Introduction/Selection Guide

Page 2 - 3 Applications

Page 4 - 5 Overview

Brake Calipers

Page 6 - 7 MU Series

Page 8 - 10 MS Series

Page 11 - 14 MR Series

Page 15 - 21 MX Series

Page 22 - 26 GMX Series

Page 27 - 29 GMR Series

Page 30 - 37 Modular Series

Page 38 Disc and Hub Assemblies

Page 39 Monitoring Units

Page 39 Materials, Traceability & Finishes

Page 40 Hydraulic Power Units

Page 41 - 44 Braking Calculations

Page 45 Application Form

Select the right Twiflex Brake to meet your requirements

The charts below illustrate the range of standard TWIFLEX disc brakes. Model-specific publications and data sheets are available for each caliper shown. To determine which will suit your application compare the braking force required with that generated by the calipers*, noting that other factors (e.g. disc speed, pad material, service factor, etc) should be considered for optimal selection. Twiflex application engineers can provide assistance for your particular application.

Spring Applied Calipers[†]

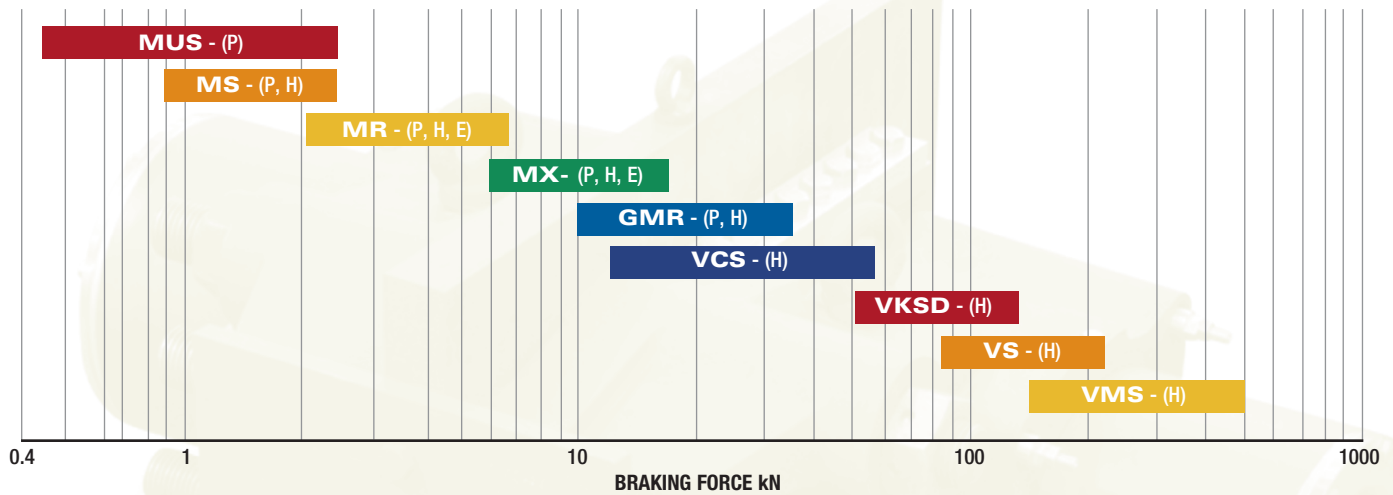

[†] KEY: (P) = Pneumatic, (H) = Hydraulic, (E) = Electrical, (M) = Mechanical

Direct Acting Calipers[†]

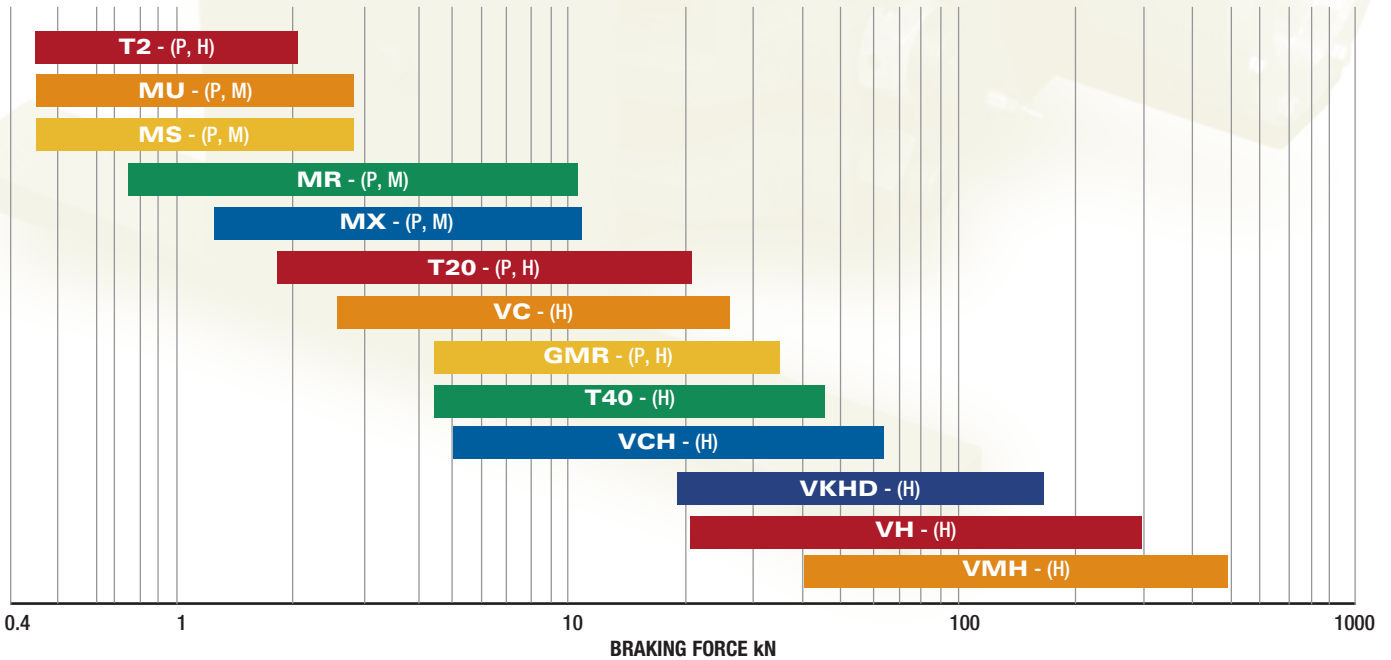

*It should be noted that the braking forces shown are for a single caliper only and multiple calipers may often be used on a disc, with available space being the typical limitation.

Twiflex disc brakes are found on industrial applications worldwide.

Metals

Twiflex brakes are used on critical applications throughout the metals processing industry for reliable dynamic, holding and emergency-stop duties. Typical applications include:

- Rolling and slitting
- Finishing and coating
- Cranes and haulage
- Shears and forging



Mining

For more than 40 years, Twiflex has been specified to provide safety-critical braking control in the mining industry. Typical applications include:

- Winders and hoists
- Conveyors
- Grinding mills
- Drag lines and shovels
- Reclaimers and haulage



Lifts and Escalators

Disc brake systems are typically used on industrial (freight) elevators and mass transit escalators. They provide safe, controlled braking in the event of power loss or emergency stop situations.



Energy

Disc brake systems are used on and off-shore in the wind, wave, tidal, and oil and gas industries.

Typical applications include:

- Wind and tidal turbine over-speed control
- Draw-works stopping and holding
- Wind turbine yaw motion control



Entertainment

Twiflex calipers are used to provide speed control, static holding, and emergency braking on a variety of applications, including:

- Theme park rides
- Simulators
- Stage gear, props and scenery
- Monorails

Marine and Shipping

Twiflex provides specialist solutions for the marine industry ranging from main propulsion shaft and thrusters braking to winch drive and weapon systems brakes.



Brake System Overview



Brake Calipers

Twiflex offers the largest range of industrial disc brake calipers in the world. Spring applied units may be retracted pneumatically, hydraulically or electrically (depending on caliper design) while most direct acting brakes have some form of positive retraction device.

In general, pneumatically applied brakes are best suited for light to medium stopping duties and for tensioning applications where a high degree of control is required. Hydraulically applied brakes address higher torque requirements, while spring applied calipers are essential where braking must be maintained in the event of supply system failure.

Mechanically applied units are suitable for light tensioning duties or where no external power is available - they may also be specified when designers wish to use their own means of actuation.



Discs

Twiflex produces a large range of standard discs and associated mounting hubs. These can be supplied pilot bored or fully machined to suit the particular mounting or shaft arrangement.

Special discs for specific applications may also be supplied on request – contact Twiflex to discuss your requirements.

Couplings

Twiflex manufactures a range of torsionally flexible, rubber-element couplings for a range of duties. Sometimes combined with a brake disc, they are a critical interface between components of a transmission system. Twiflex engineers are available to discuss, analyse and advise on coupling suitability for any application, and provide the technical support needed.



Brake Pads

It is possible to make a realistic assessment of expected pad life based on analytical and test data. Pad life is determined by the area of the brake pad, the energy dissipated during braking and the peak braking path temperature, and must be a consideration whenever the duty includes dynamic braking.



Hydraulic Power Units

A number of electro-hydraulic power pack options are available, from standard 'on/off' control units to fully customised closed-loop braking systems. All require careful selection in order to ensure full compatibility with the type and number of brakes being controlled. Consultation with Twiflex engineers is recommended.

- The LC range provides a basic on/off control for a range of Twiflex spring-applied and direct acting hydraulic calipers
- The MP range of modular power units offers flexibility of design and function
- Custom units are available on request



Monitoring Equipment

Every brake installation requires monitoring visually, mechanically, or electrically; particularly spring applied brakes on safety-critical applications. Twiflex can supply a range of electro-mechanical and electronic monitoring units and limit switches to indicate any combination of brake status or pad condition.

Materials, Finishes and Traceability

Twiflex is approved to BS EN ISO 9001:2000 and can offer material and dimensional certification by Lloyds Register and other regulatory authorities. All units are supplied with a standard Twiflex finish while special protective coatings to suit particular environments are available on request.

MU Series

MU Disc Brake Caliper Range

The Twiflex MU series of disc brake calipers is the smallest in the Twiflex range and is primarily intended for light stopping and holding duties. Its design permits left or right-handed assembly.

The caliper is suitable for use with a disc thickness of 8mm, however, with a revised thruster mounting arrangement, may be used with discs 12.7mm thick. Minimum disc diameter is 150mm. A range of brake discs is available from Twiflex (see Disc and Hub Assemblies).

Fixing bolt to be supplied by the customer.

For pneumatic operation use dry, filtered and non-lubricated compressed air. Pneumatic brakes require a control valve, operated either manually or by pneumatic or electrical signal.

The ratings shown on the graphs are based on fully bedded in and conditioned brake pads with a nominal friction coefficient $\mu = 0.4$. Twiflex disc brakes must be used with Twiflex asbestos free brake pads.

Effective disc radius = actual radius (m) - 0.02m.

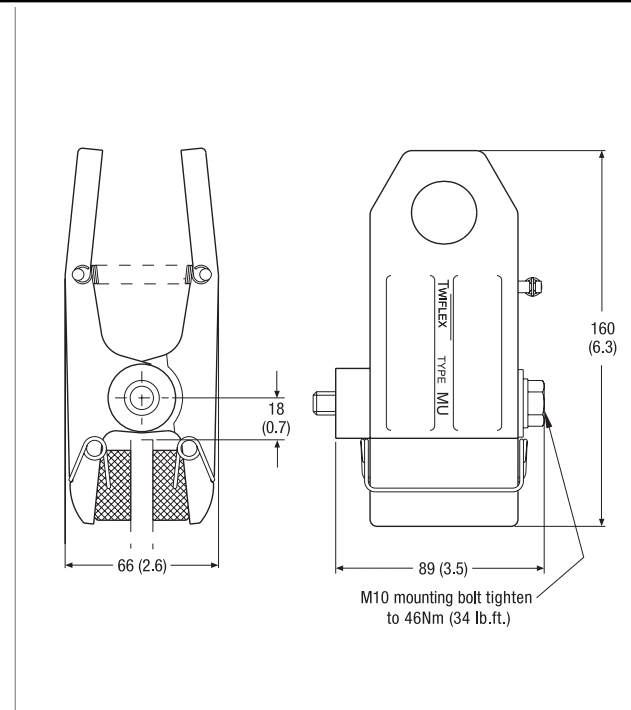

MU3 Pneumatically Applied – Spring Released

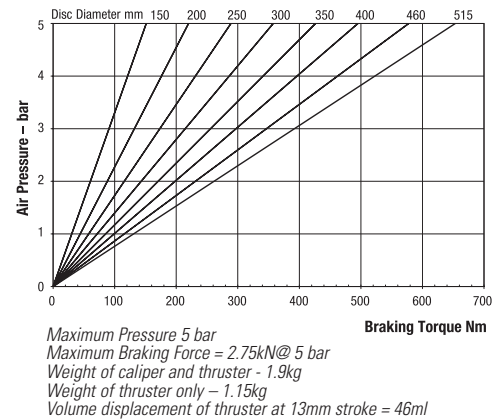
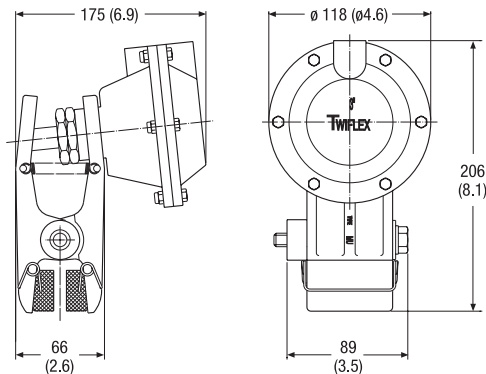

MUP Pneumatically Applied – Spring Released

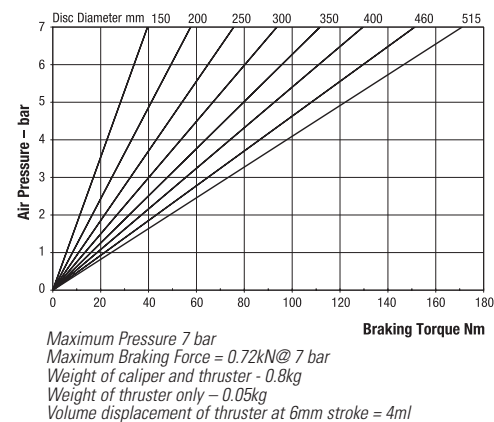
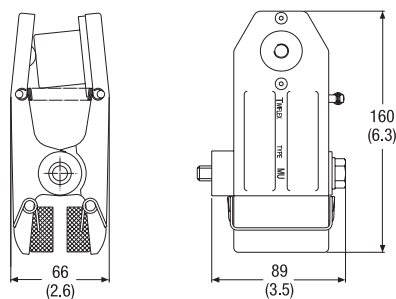

Retraction pressures where shown are calculated and may vary depending on spring tolerance.

MUS2 Spring Applied – Pneumatically Released

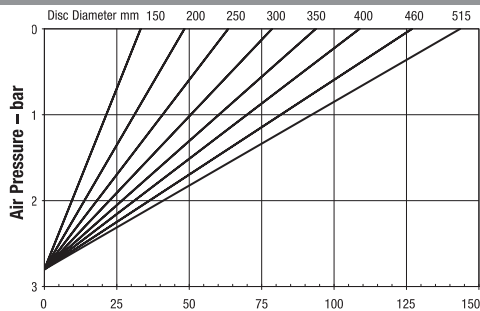
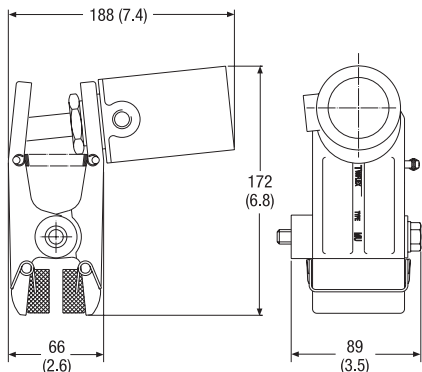

Maximum Pressure = 7 bar
 Minimum Pressure for full retraction = 4.3 bar
 Maximum Braking Force = 0.6kN

Braking Torque Nm

Weight of caliper and thruster – 1.36kg
 Weight of thruster only – 0.61kg
 Volume displacement of thruster at full retraction = 20ml

MUS3 Spring Applied – Pneumatically Released

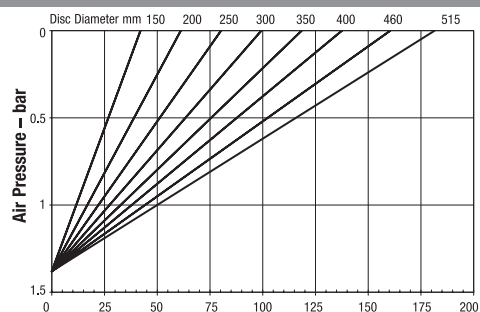
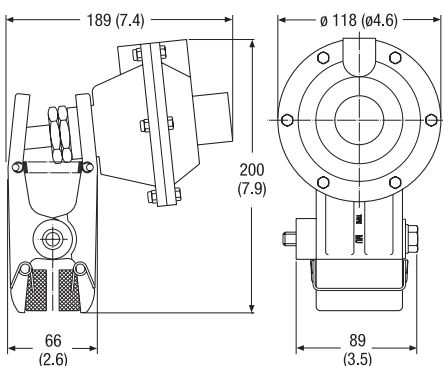

Maximum Pressure = 7 bar
 Minimum Pressure for full retraction = 1.75 bar
 Maximum Braking Force = 0.76kN

Braking Torque Nm

Weight of caliper and thruster – 2.2kg
 Weight of thruster only – 1.45kg
 Volume displacement of thruster at full retraction = 46ml

MUS4 Spring Applied – Pneumatically Released

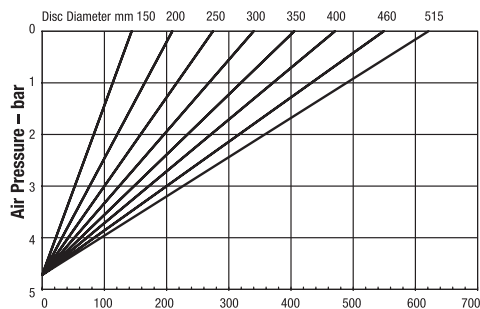
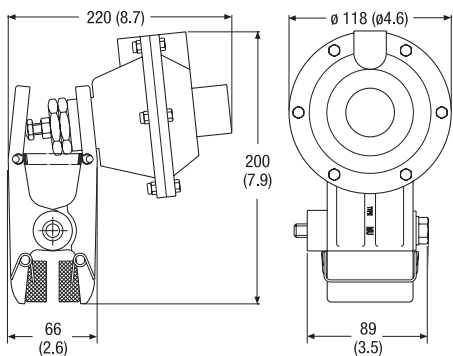

Maximum Pressure = 7 bar
 Minimum Pressure for full retraction = 6.2bar
 Maximum Braking Force = 2.6kN

Braking Torque Nm

Weight of caliper and thruster – 2.24kg
 Weight of thruster only – 1.49kg
 Volume displacement of thruster at full retraction = 46ml

MUH Mechanically Applied – Hand Operated

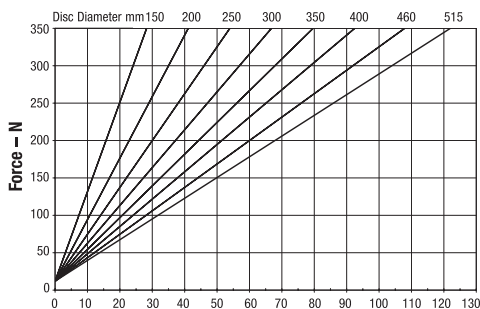
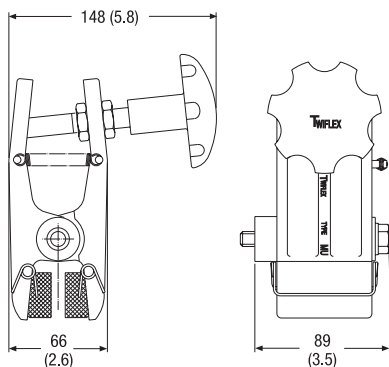

Weight of caliper and thruster – 1.9kg
 Weight of hand wheel assembly only – 1.15kg

Braking Torque Nm

Maximum Braking Force = 0.51kN

Retraction pressures where shown are calculated and may vary depending on spring tolerance.

MS Series

MS Disc Brake Caliper Range

The Twiflex MS series of disc brake calipers is suitable for use with a disc thickness of 12.7mm. Minimum disc diameter is 250mm.

Normally one or two calipers are used per disc, mounted horizontally (i.e. at the 3 o'clock or 9 o'clock position) to prevent rubbing of one brake pad due to self-weight of the thruster. A range of brake discs is available from Twiflex (see Disc and Hub Assemblies).

For pneumatic operation use dry, filtered and non-lubricated compressed air. Pneumatic brakes require a control valve, operated either manually or by pneumatic or electrical signal.

The ratings shown on the graphs are based on fully bedded in and conditioned brake pads with a nominal friction coefficient $\mu = 0.4$. Twiflex disc brakes must be used with Twiflex asbestos free brake pads.

Effective disc radius = actual radius (m) - 0.03m.

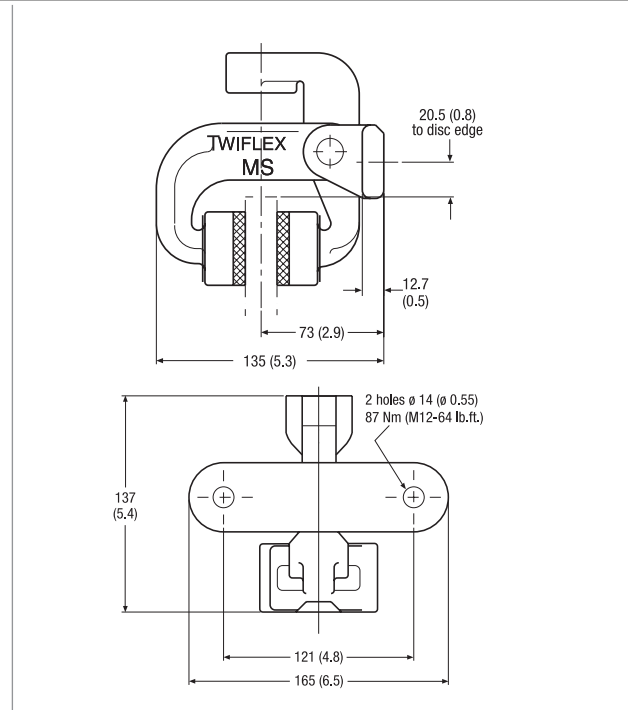

MSA Pneumatically Applied – Spring Released

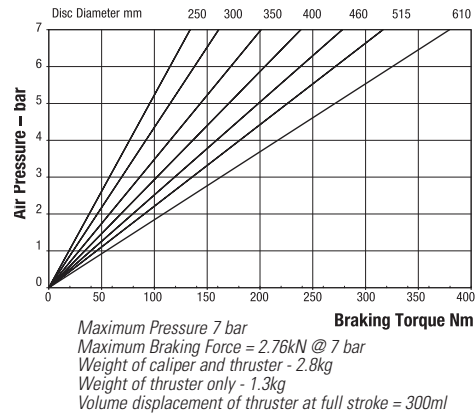
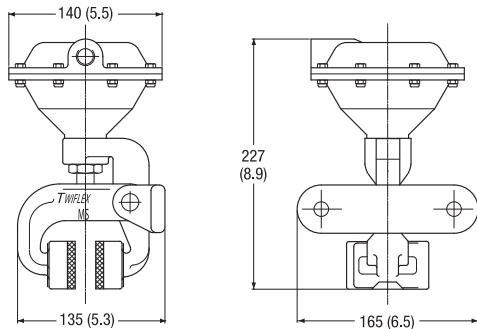

MSD Pneumatically Applied – Spring Released

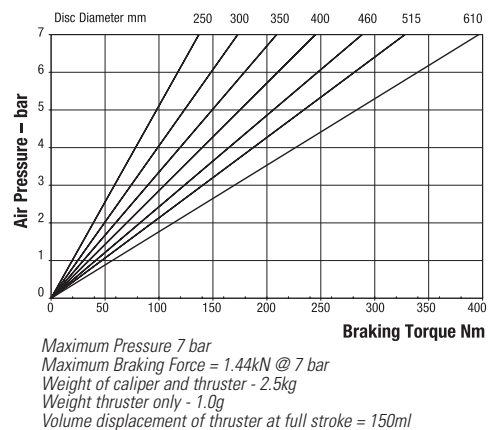
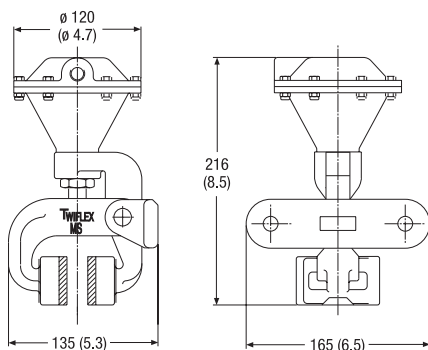

Retraction pressures where shown are calculated and may vary depending on spring tolerance.

MSE Pneumatically Applied – Spring Released

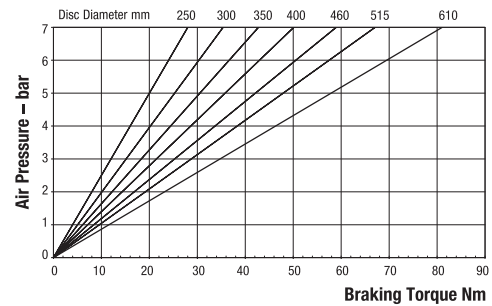
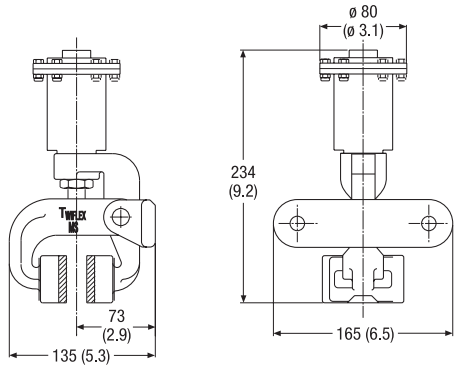

Maximum Pressure 7 bar
 Maximum Braking Force = 0.29kN @ 7 bar
 Weight of caliper and thruster - 1.91kg

Weight of thruster only - 0.41kg
 Volume displacement of thruster at full stroke = 8ml

MSG Pneumatically Applied – Spring Released

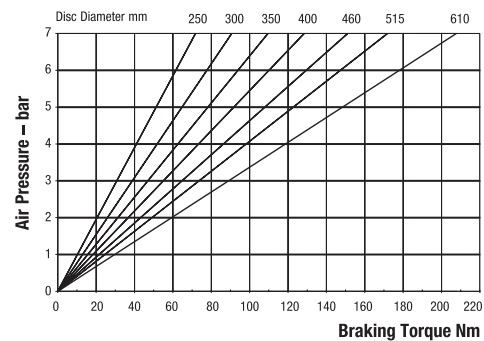
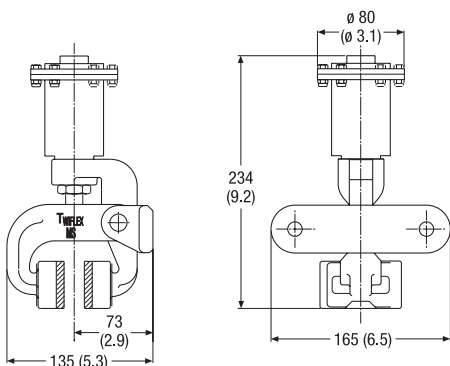

Maximum Pressure 7 bar
 Maximum Braking Force = 0.76kN @ 7 bar
 Weight of caliper and thruster - 1.89kg

Weight of thruster only - 0.39kg
 Volume displacement of thruster at full stroke = 21ml

MSF Mechanically Applied – Lever Operated

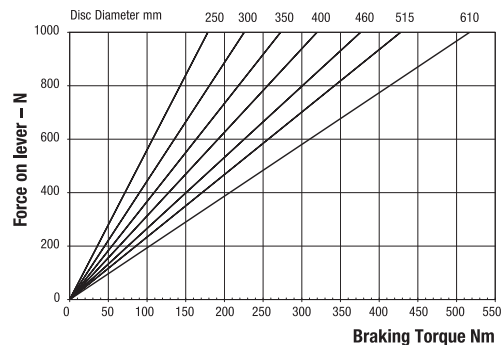
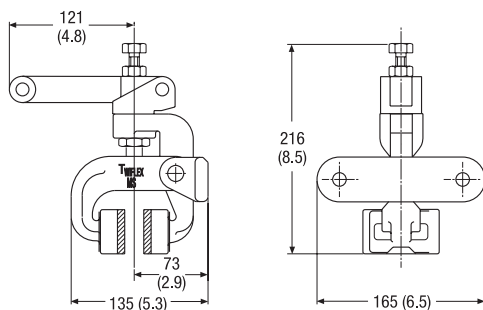

Maximum Braking Force =
 1.88kN @ 0.8kN force on lever

Weight of caliper and lever assembly - 2.13kg
 Weight of lever assembly only - 0.63kg

MSH Mechanically Applied – Hand Operated

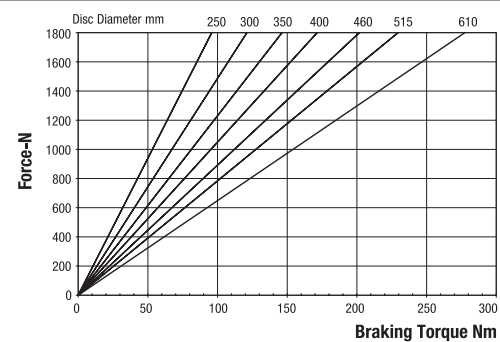
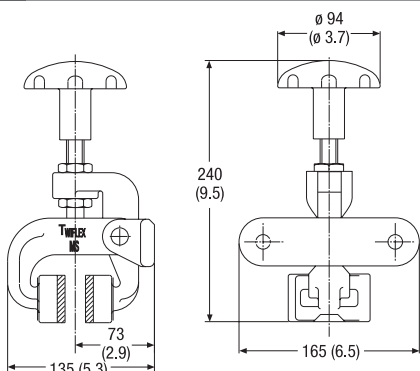

Maximum Braking Force = 1.01kN
 Weight of caliper and hand wheel
 assembly - 2.53kg

Weight of hand wheel assembly only - 1.03kg

Retraction pressures where shown are calculated and may vary depending on spring tolerance.

MS Series

MSK Spring Applied – Pneumatically Released, Self Adjusting

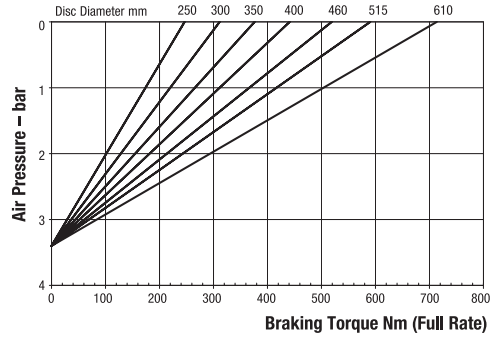
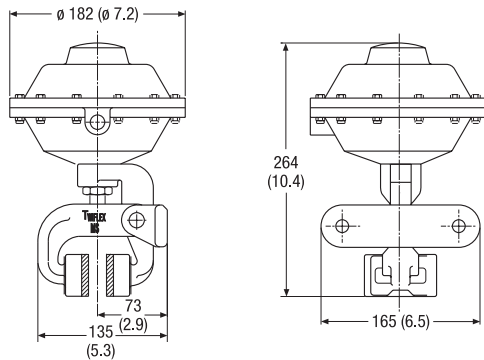

Maximum Braking Force full rate: 2.6kN
 Minimum Pressure for full retraction: 5 bar
 Weight of caliper and thruster - 4.9kg
 Weight of thruster only - 3.4kg
 Volume displacement of thruster at full retraction = 950ml

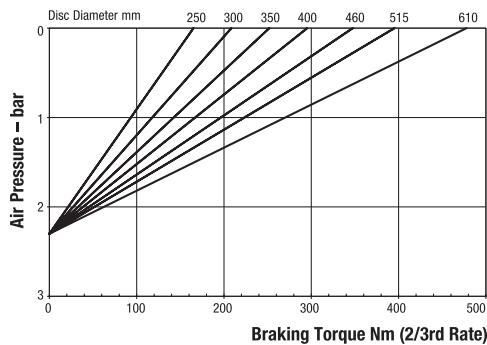

Maximum Braking Force 2/3rd rate: 1.74kN
 Minimum Pressure for full retraction: 3.3 bar
 Weight of caliper and thruster - 4.9kg
 Weight of thruster only - 3.4kg
 Volume displacement of thruster at full retraction = 950ml

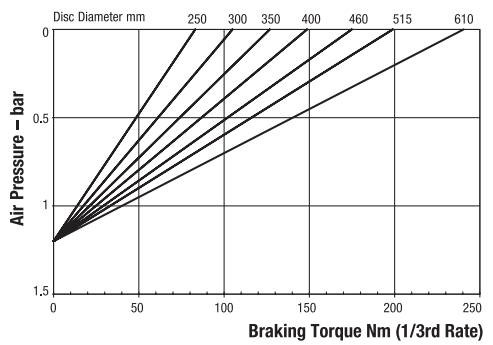

Maximum Braking Force 1/3rd rate: 0.87kN
 Minimum Pressure for full retraction: 1.7 bar
 Weight of caliper and thruster - 4.9kg
 Weight of thruster only - 3.4kg
 Volume displacement of thruster at full retraction = 950ml

MSL Spring Applied – Hydraulically Released, Self Adjusting

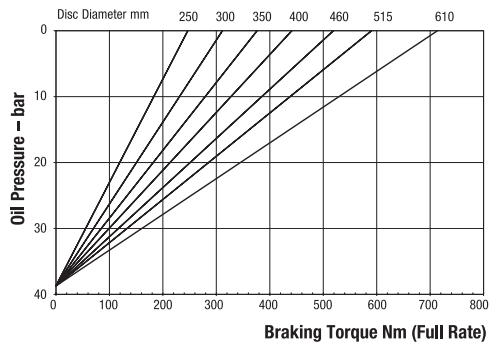
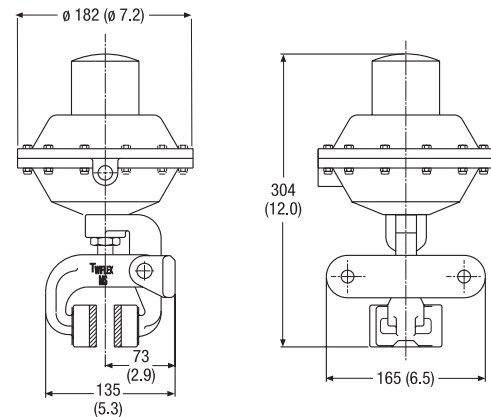

Maximum Braking Force full rate: 2.6kN
 Minimum Pressure for full retraction: 50 bar
 Weight of caliper and thruster - 5.5kg
 Weight of thruster only - 4kg
 Volume displacement of thruster at 4mm retraction = 5ml

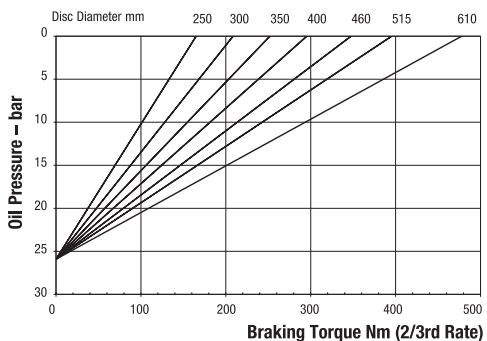

Maximum Braking Force 2/3rd rate: 1.74kN
 Minimum Pressure for full retraction: 33 bar
 Weight of caliper and thruster - 5.5kg
 Weight of thruster only - 4kg
 Volume displacement of thruster at 4mm retraction = 5ml

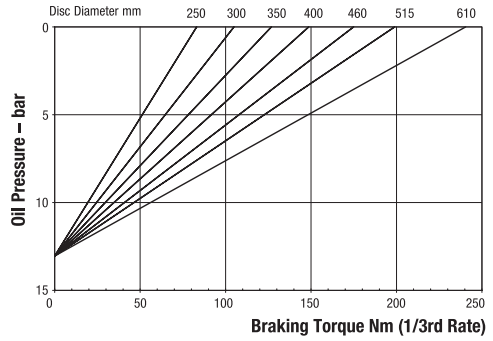

Maximum Braking Force 1/3rd rate: 0.87kN
 Minimum Pressure for full retraction: 17 bar
 Weight of caliper and thruster - 5.5kg
 Weight of thruster only - 4kg
 Volume displacement of thruster at 4mm retraction = 5ml

Retraction pressures where shown are calculated and may vary depending on spring tolerance.

MR Disc Brake Caliper Range

The Twiflex MR series of disc brake calipers is suitable for use with discs of 12.7mm or 25.4mm thick. Minimum disc diameter is 250mm. Minimum disc diameter for the MR2 is 460mm.

Normally one or two calipers are used per disc, but the number may be increased depending on disc size. The brakes may be positioned at any angle around the periphery of the disc, but should ideally be mounted horizontally (i.e. at the 3 o'clock or 9 o'clock position). If the caliper mounting angle is greater than 10° from the horizontal, or on vertical shaft applications, it should be fitted with an equalising link. A range of brake discs is available from Twiflex (see Disc and Hub Assemblies).

For pneumatic operation use dry, filtered and non-lubricated compressed air. Pneumatic brakes require a control valve, operated either manually or by pneumatic or electrical signal.

The ratings shown on the graphs are based on fully bedded in and conditioned brake pads with a nominal friction coefficient $\mu = 0.4$. Twiflex disc brakes must be used with Twiflex asbestos free brake pads.

Effective disc radius = actual radius (m) – 0.03m.

MR Disc Brake Caliper

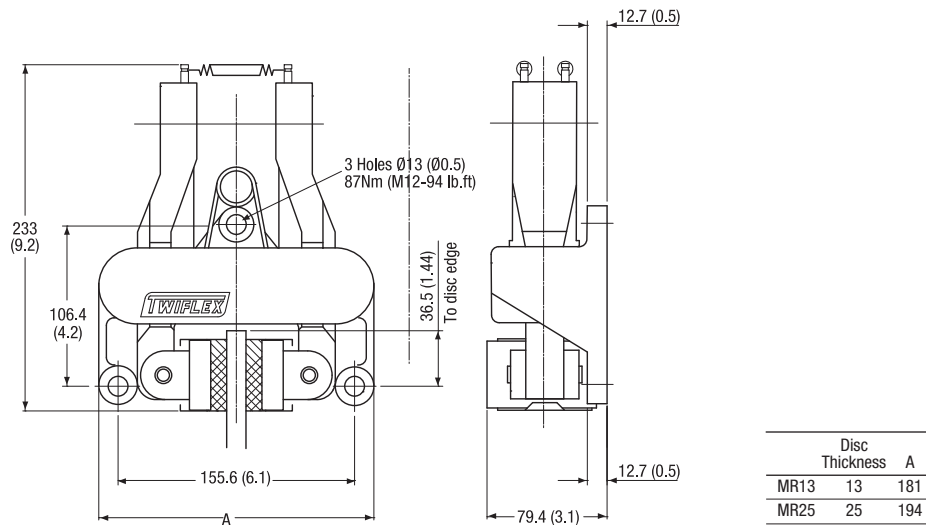

MR2 Disc Brake Caliper

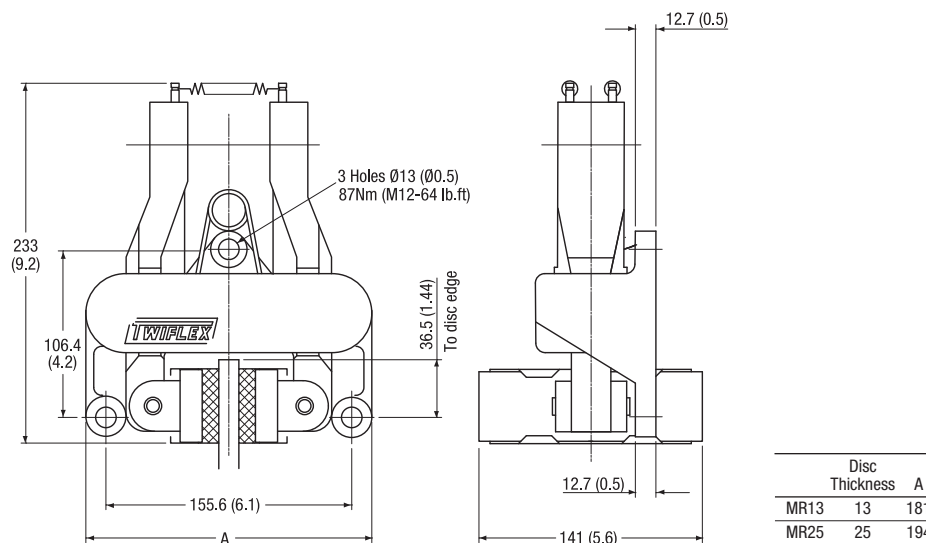

Retraction pressures where shown are calculated and may vary depending on spring tolerance.

MR Series

MRA Pneumatically Applied – Spring Released

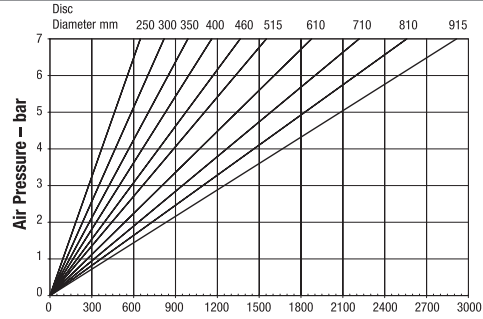
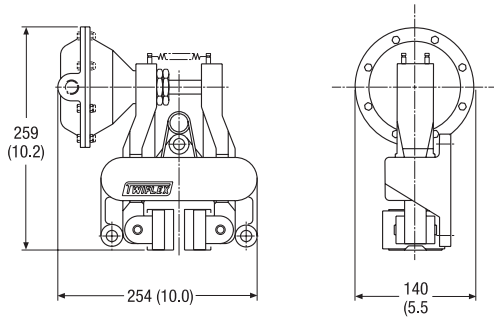

Maximum Pressure 7 bar
 Maximum Braking Force = 6.9kN @ 7 bar
 Weight of MR caliper and thruster - 7.82kg
 Weight of MR2 caliper and thruster - 8.32kg

Braking Torque Nm
 Weight of thruster only - 1.32kg
 Volume displacement of thruster at full stroke = 300

MRB Pneumatically Applied – Spring Released

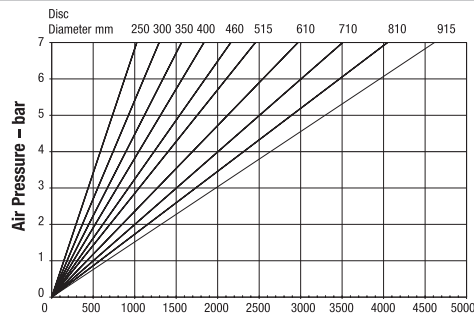
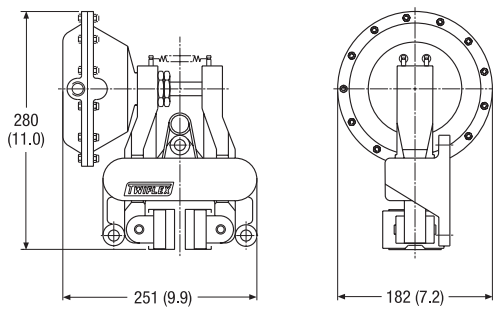

Maximum Pressure 7 bar
 Maximum Braking Force = 10.8kN @ 7 bar
 Weight of MR caliper and thruster - 8.56kg
 Weight of MR2 caliper and thruster - 9.06kg

Braking Torque Nm
 Weight of thruster only - 2.06kg
 Volume displacement of thruster at full stroke = 426ml

MRD Pneumatically Applied – Spring Released

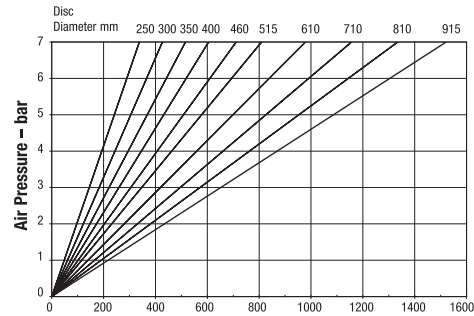
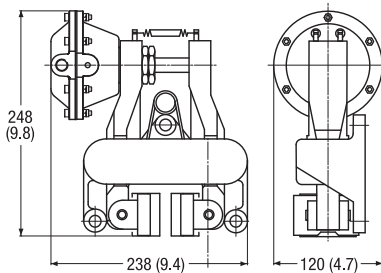

Maximum Pressure 7 bar
 Maximum Braking Force = 3.5kN @ 7 bar
 Weight of MR caliper and thruster - 7.65kg
 Weight of MR2 caliper and thruster - 8.15kg

Braking Torque Nm
 Weight thruster only - 1.15kg
 Volume displacement of thruster at full stroke = 150ml

MRE Pneumatically Applied – Spring Released

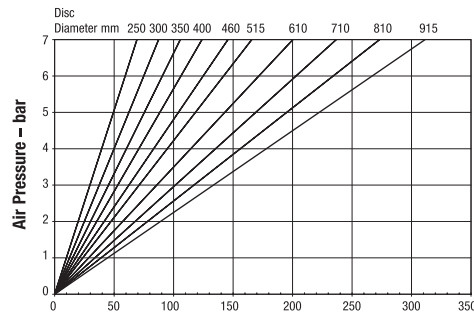
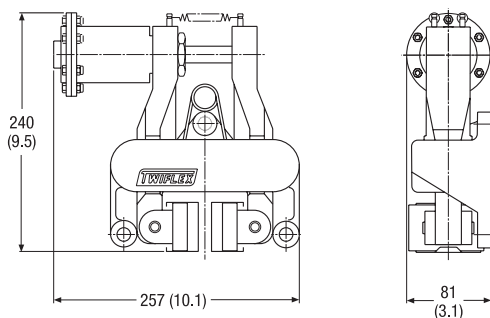

Maximum Pressure 7 bar
 Maximum Braking Force = 0.74kN @ 7 bar
 Weight of MR caliper and thruster - 6.84kg
 Weight of MR2 caliper and thruster - 7.34kg

Braking Torque Nm
 Weight of thruster only - 0.34kg
 Volume displacement of thruster at full stroke = 25ml

Retraction pressures where shown are calculated and may vary depending on spring tolerance.

MRG Pneumatically Applied – Spring Released

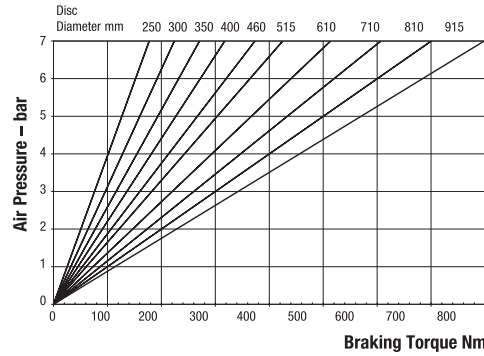
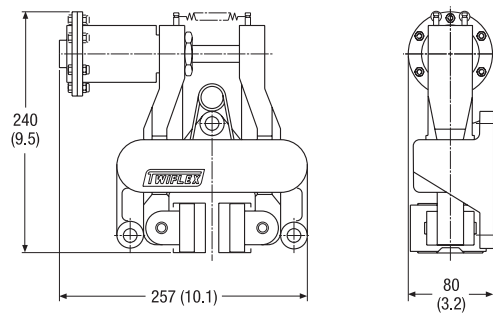

Maximum Pressure 7 bar
 Maximum Braking Force = 1.9kN @ 7 bar
 Weight of MR caliper and thruster - 6.8kg

Weight of MR2 caliper and thruster - 7.3kg
 Weight of thruster only - 0.3kg
 Volume displacement of thruster at full stroke = 64ml

MRH Mechanically Applied – Lever Operated

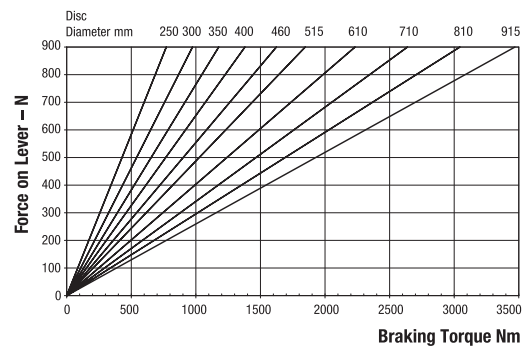
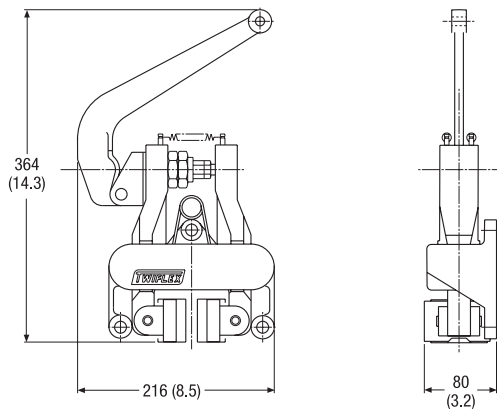

Weight of MR caliper and thruster - 7.9kg
 Weight of MR2 caliper and thruster - 8.4kg

Weight of lever assembly only - 1.4kg
 Maximum Braking Force = 8.3kN @ 0.9kN force on lever

MRW Mechanically Applied – Hand Operated

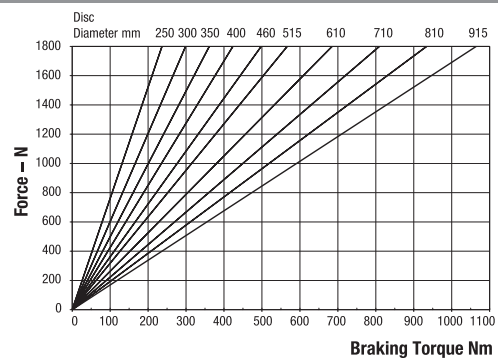
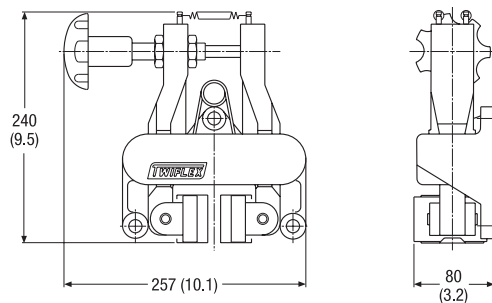

Weight of MR caliper and hand wheel assembly - 7.8kg
 Weight of MR2 caliper and hand wheel - 8.3kg

Weight of hand wheel assembly only - 1.3kg
 Maximum Braking Force = 2.68kN

Retraction pressures where shown are calculated and may vary depending on spring tolerance.

MR Series

MRK Spring Applied – Pneumatically Released, Self Adjusting

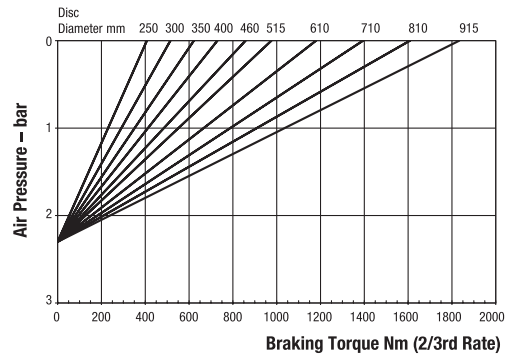
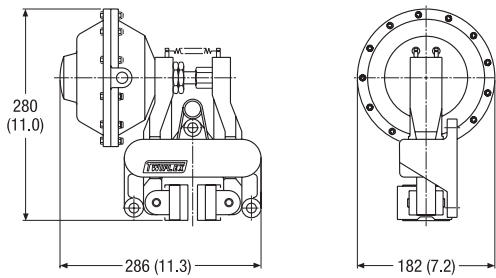

Minimum Pressure for full retraction: 3.3 bar
 Maximum Braking Force 2/3rd rate: 4.3kN
 Weight of MR caliper and thruster - 10.0kg
 Weight of MR2 caliper and thruster - 10.5kg

Weight of thruster only - 3.5kg
 Volume displacement of thruster at full retraction is 950ml

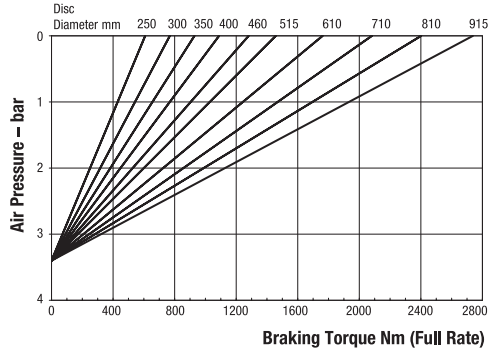

Minimum Pressure for full retraction: 5 bar
 Maximum Braking Force full rate: 6.4kN
 Weight of MR caliper and thruster - 10.0kg
 Weight of MR2 caliper and thruster - 10.5kg

Weight of thruster only - 3.5kg
 Volume displacement of thruster at full retraction is 950ml

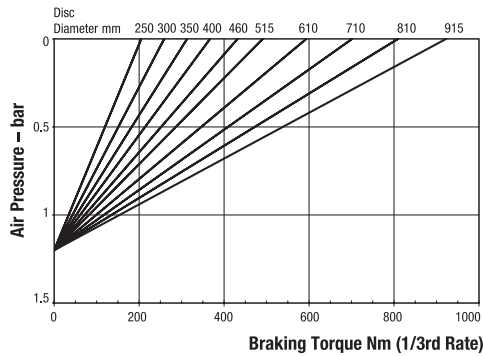

Minimum Pressure for full retraction: 1.7 bar
 Maximum Braking Force 1/3rd rate: 2.2kN
 Weight of MR caliper and thruster - 10.0kg
 Weight of MR2 caliper and thruster - 10.5kg

Weight of thruster only - 3.5kg
 Volume displacement of thruster at full retraction is 950ml

MRL Spring Applied – Hydraulically Released, Self Adjusting

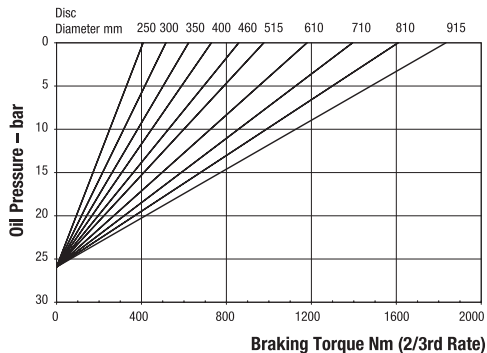
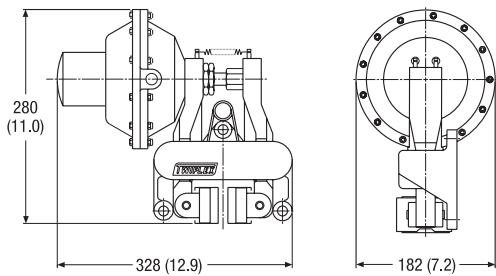

Minimum Pressure for full retraction 33 bar
 Maximum Braking Force 2/3rd rate: 4.3kN
 Weight of MR caliper and thruster - 10.5kg
 Weight of MR2 caliper and thruster - 11kg

Weight of thruster only - 4kg
 Volume displacement of thruster at 4mm retraction = 5ml

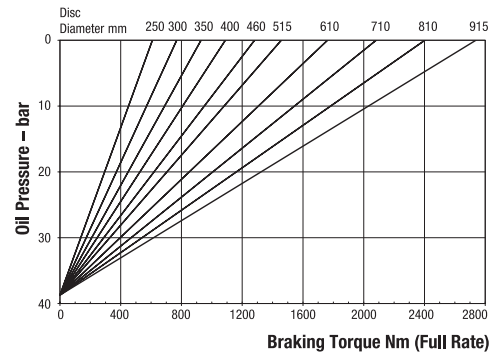

Minimum Pressure for full retraction: 50 bar
 Maximum Braking Force full rate: 6.4kN
 Weight of MR caliper and thruster - 10.5kg
 Weight of MR2 caliper and thruster - 11kg

Weight of thruster only - 4kg
 Volume displacement of thruster at 4mm retraction = 5ml

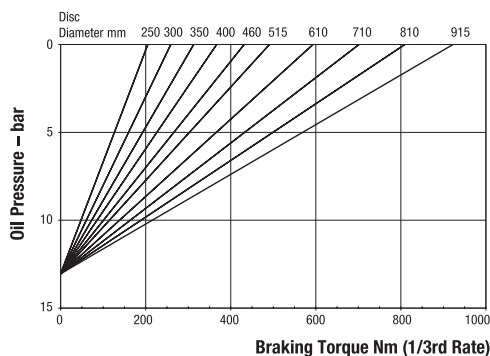

Minimum Pressure for full retraction: 17 bar
 Maximum Braking Force 1/3rd rate: 2.2kN
 Weight of MR caliper and thruster - 10.5kg
 Weight of MR2 caliper and thruster - 11kg

Weight of thruster only - 4kg
 Volume displacement of thruster at 4mm retraction = 5ml

Retraction pressures where shown are calculated and may vary depending on spring tolerance.

MX Disc Brake Caliper Range

The Twiflex MX13, MX25, MX30 and MX40 series of disc brake calipers is suitable for use with discs of 12.7mm, 25.4mm, 30mm and 40mm thick respectively. The SMX caliper is only suitable for use with discs 12.7mm thick. Minimum disc diameter is 300mm.

The MX/SMX calipers may be used with any of the Twiflex series of thrusters and feature a patented link mechanism to ensure uniform pad wear.

Normally one or two calipers are used per disc, but the number may be increased depending on disc size. The brakes may be positioned at any angle around the periphery of the disc, but should ideally be mounted horizontally (i.e. at the 3 o'clock or 9 o'clock position). If the caliper mounting angle is greater than 10° from the horizontal, or on vertical

shaft applications, it should be fitted with an inclined mounting kit or equalising link. A range of brake discs is available from Twiflex (see Disc and Hub Assemblies).

For pneumatic operation use dry, filtered and non-lubricated compressed air. Pneumatic brakes require a control valve, operated either manually or by pneumatic or electrical signal.

The ratings shown on the graphs are based on fully bedded in and conditioned brake pads with a nominal friction coefficient $\mu = 0.4$. Twiflex disc brakes must be used with Twiflex asbestos free brake pads.

Effective disc radius = actual radius (m) – 0.033m.

MX Disc Brake Caliper

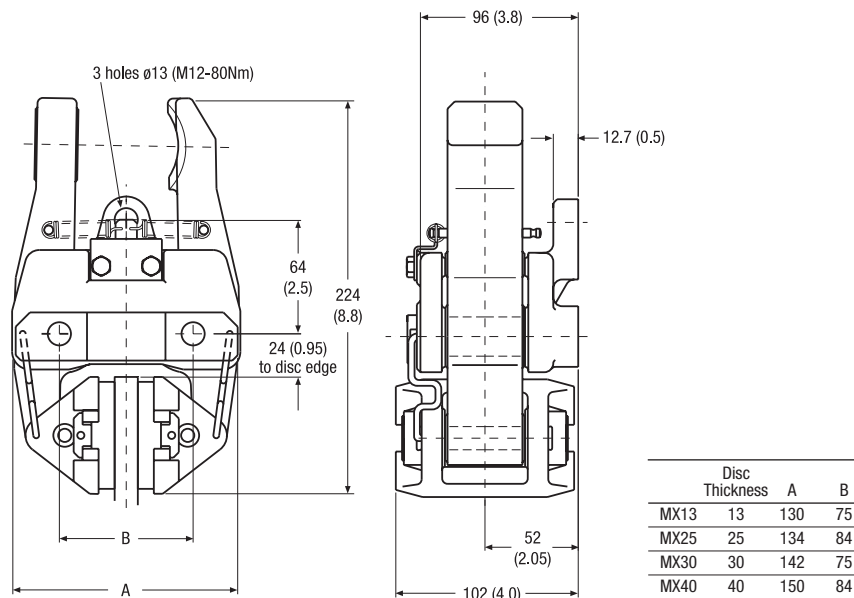

SMX Disc Brake Caliper

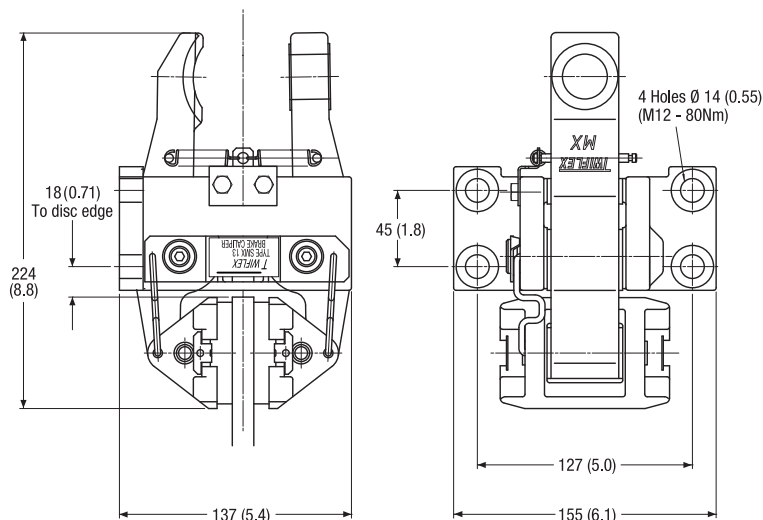

Retraction pressures where shown are calculated and may vary depending on spring tolerance.

MX Series

MXA Pneumatically Applied – Spring Released

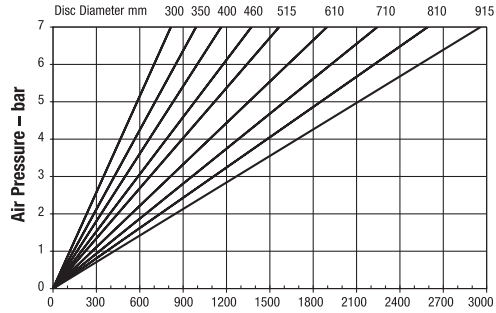
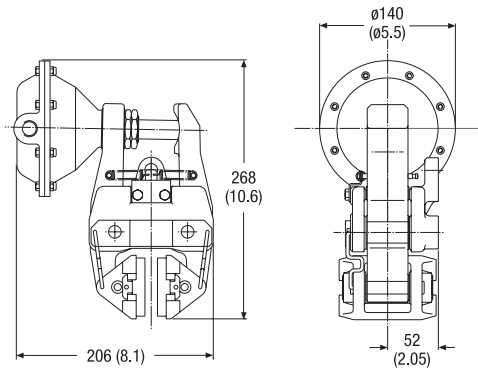

Maximum Pressure 7 bar
 Maximum Braking Force = 6.9kN @ 7 bar
 Weight of caliper and thruster - 8.32kg

Braking Torque Nm
 Weight of thruster only - 1.32kg
 Volume displacement of thruster at full stroke = 300ml

MXB Pneumatically Applied – Spring Released

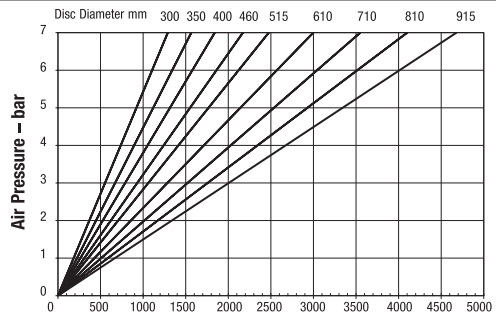
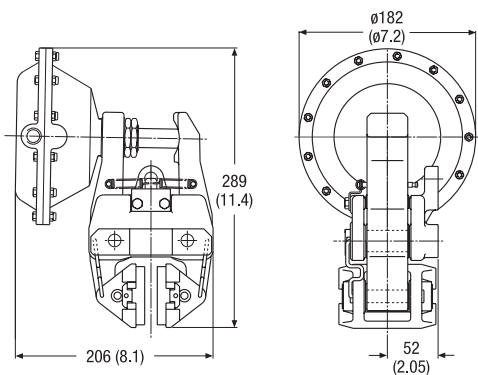

Maximum Pressure 7 bar
 Maximum Braking Force = 11kN @ 7 bar
 Weight of caliper and thruster - 9.06kg

Braking Torque Nm
 Weight of thruster only - 2.06kg
 Volume displacement of thruster at full stroke = 426ml

MXD Pneumatically Applied – Spring Released

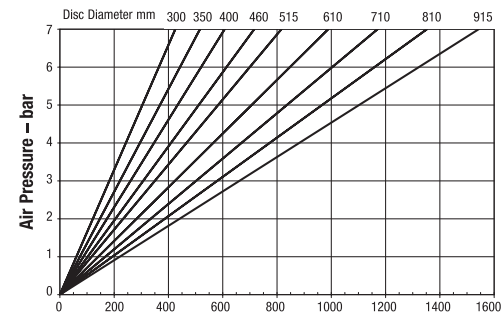
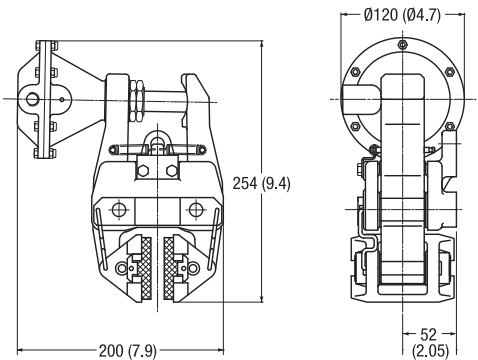

Maximum Pressure 7 bar
 Maximum Braking Force = 3.6kN @ 7 bar
 Weight of caliper and thruster - 8.15kg

Braking Torque Nm
 Weight thruster only - 1.15kg
 Volume displacement of thruster at full stroke = 150ml

MXE Pneumatically Applied – Spring Released

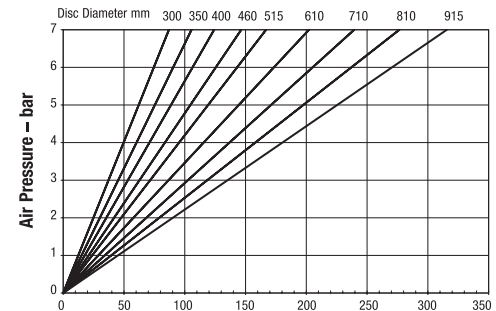
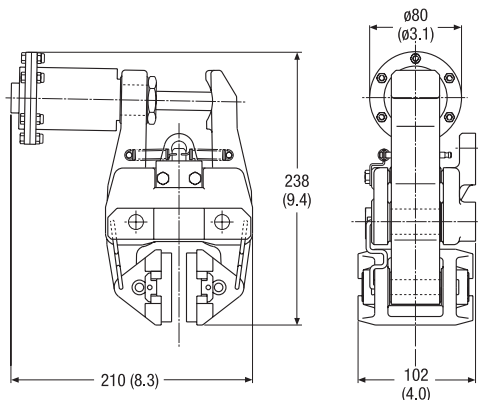

Maximum Pressure 7 bar
 Maximum Braking Force = 0.74kN @ 7 bar
 Weight of caliper and thruster - 7.34kg

Braking Torque Nm
 Weight of thruster only - 0.34kg
 Volume displacement of thruster at full stroke = 25ml

Retraction pressures where shown are calculated and may vary depending on spring tolerance.

MXG Pneumatically Applied – Spring Released

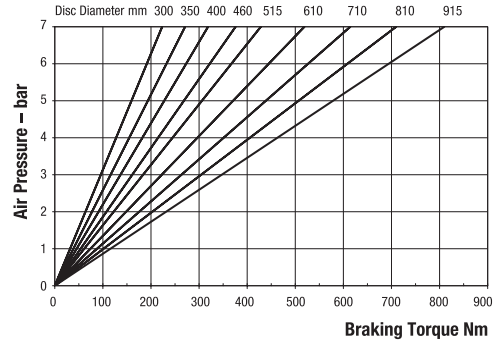
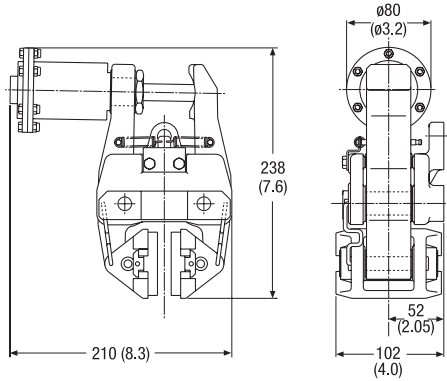

Maximum Pressure 7 bar
 Maximum Braking Force = 1.9kN @ 7 bar
 Weight of caliper and thruster - 7.3kg

Weight of thruster only - 0.3kg
 Volume displacement of thruster at full stroke = 64ml

MXH Mechanically Applied – Lever Operated

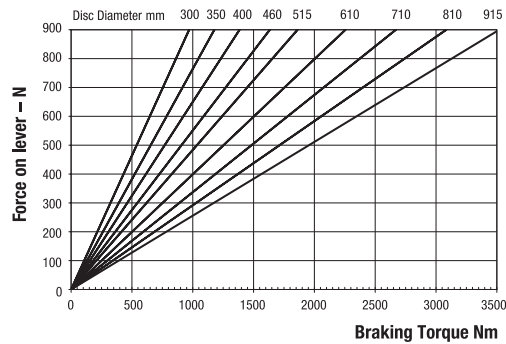
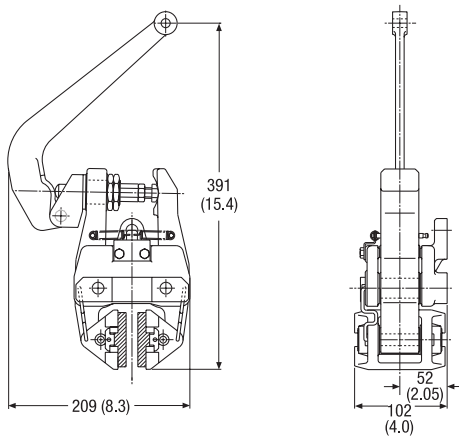

Weight of caliper and lever assembly - 8.4kg
 Weight of lever assembly only - 1.4kg

Maximum Braking Force = 8.3kN @ 0.9kN force on lever

MXW Mechanically Applied – Hand Operated

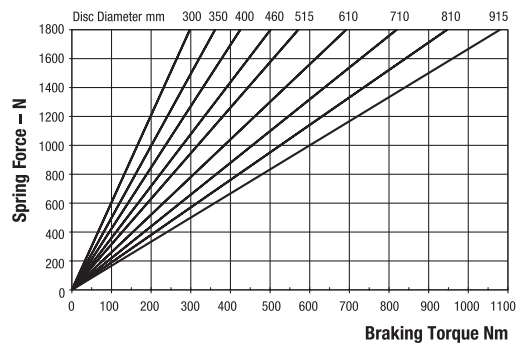
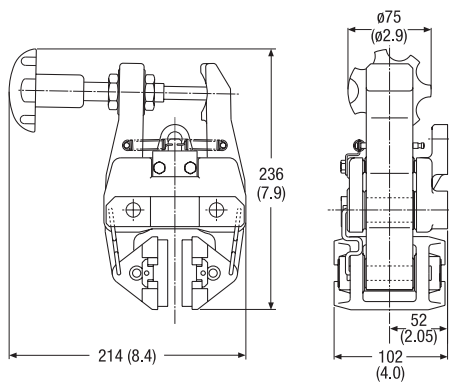

Weight of caliper and hand wheel assembly - 8.3kg
 Weight of hand wheel assembly only - 1.3kg

Maximum Braking Force = 2.68kN

Retraction pressures where shown are calculated and may vary depending on spring tolerance.

MX Series

MXEA Spring Applied – Electrically Released, Self Adjusting

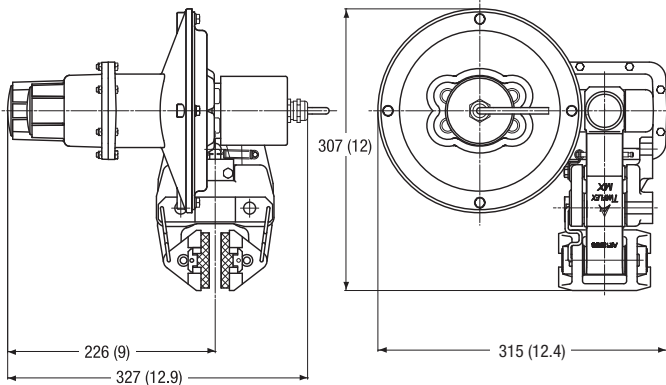

Maximum Braking Force = 6kN
Weight of caliper and actuator - 15.7kg

Weight actuator only - 8.7kg
Weight of controller - 5.5kg

The EA actuator is a spring applied, electrically released unit designed for use with the Twiflex MX range of disc brake calipers. A 175W pancake motor drives a ball screw mechanism, retracting the brake.

A feature of the unit is a patented self-adjusting mechanism which maintains a constant air gap (and consequently braking force) between pad and disc as the pads wear.

The assembly is contained in a rugged, cast aluminium housing, designed for service in the harshest environments, which mounts directly to one arm of the MX caliper.

The MXEA is supplied complete with a solid state controller, suitable for all AC supply voltages, which converts the supply to the required DC output for the pancake motor. A 24VDC unit is also available. The brake is released when power to the controller is switched on, and applied when power is disconnected. Controlled application of the brake occurs, electrically damped by using the motor back E.M.F. and a damping resistor.

The controller is housed in a strong, steel, wall mounted enclosure (215mm x 215mm x 150mm deep), protected to IP44 as standard (higher rating on request).

Braking force adjustable to 50% of maximum.

MXS Spring Applied – Pneumatically Released, Self Adjusting

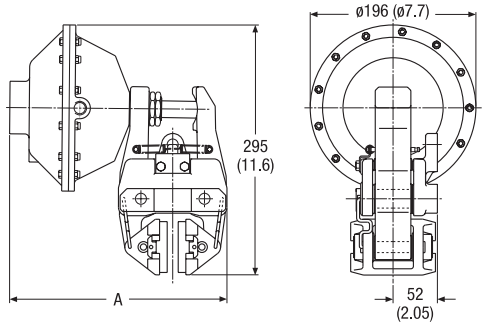

(With new pads)

Caliper	A
MX 13	269.5
MX 25	276.0
MX 30	275.5
MX 40	284.0

For XS9.6 add 11mm

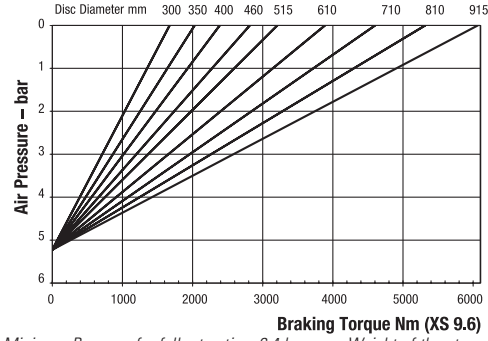

Minimum Pressure for full retraction: 6.4 bar
Maximum Braking Force XS 9.6: 14.3kN
Weight of caliper and thruster - 12.1kg

Weight of thruster only - 5.1kg
Volume displacement of thruster at full retraction = 1.19 l

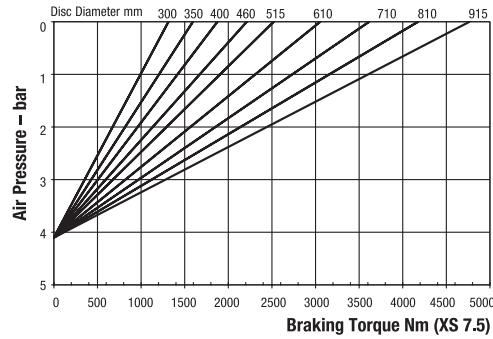

Minimum Pressure for full retraction: 5.5 bar
Maximum Braking Force XS 7.5: 11.2kN
Weight of caliper and thruster - 11.9kg

Weight of thruster only - 4.9kg
Volume displacement of thruster at full retraction = 1.19 l

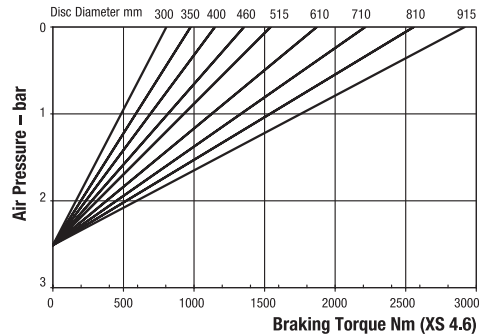

Minimum Pressure for full retraction: 3.1 bar
Maximum Braking Force XS 4.6: 6.8kN
Weight of caliper and thruster - 11.5kg

Weight of thruster only - 4.5kg
Volume displacement of thruster at full retraction = 1.19 l

MXSH Spring Applied – Hydraulically Released, Self Adjusting

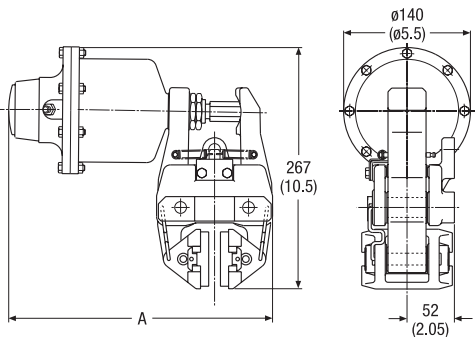

(With new pads)

Caliper	A
MX 13	295.5
MX 25	302.0
MX 30	301.5
MX 40	310.0

For XSH9.6 add 25mm

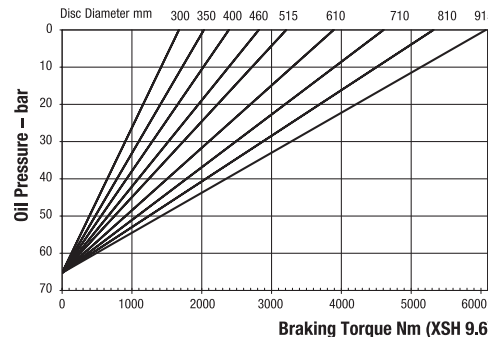

Minimum Pressure for full retraction: 82 bar
Maximum Braking Force XSH 9.6: 14.3kN
Weight of caliper and thruster - 11.6kg

Weight of thruster only - 4.6kg
Volume displacement of thruster at 6mm retraction = 9.1ml

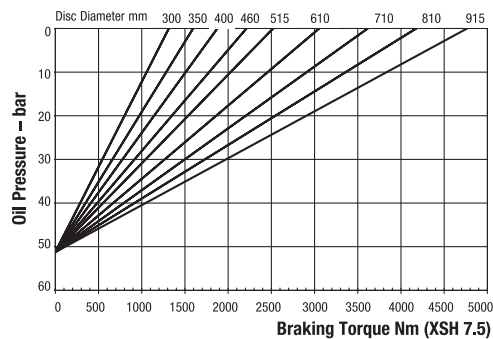

Minimum Pressure for full retraction: 65 bar
Maximum Braking Force XSH 7.5: 11.2kN
Weight of caliper and thruster - 11.4kg

Weight of thruster only - 4.4kg
Volume displacement of thruster at 6mm retraction = 9.1ml

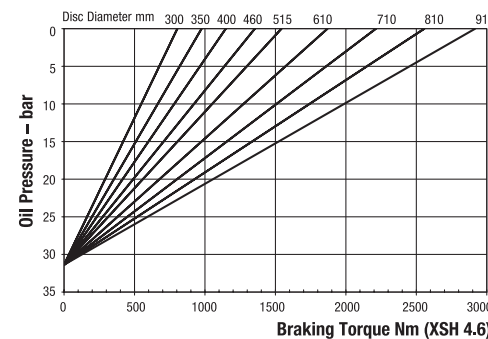

Minimum Pressure for full retraction: 40 bar
Maximum Braking Force XSH 4.6: 6.8kN
Weight of caliper and thruster - 11kg

Weight of thruster only - 4kg
Volume displacement of thruster at 6mm retraction = 9.1ml

Retraction pressures where shown are calculated and may vary depending on spring tolerance.

MX Series

MXK Spring Applied – Pneumatically Released, Self Adjusting

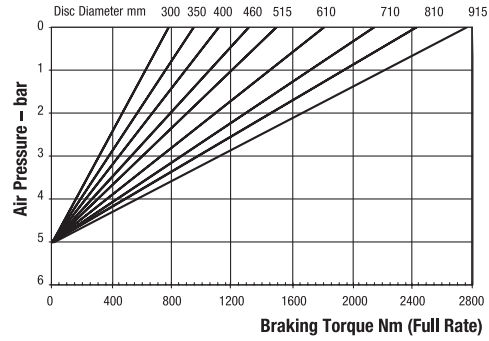
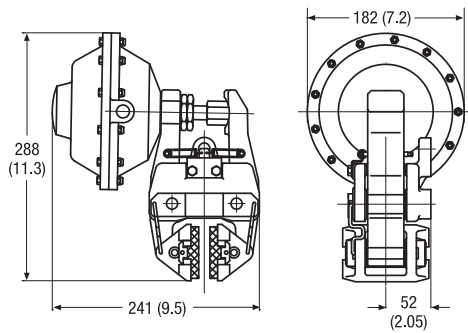

Minimum Pressure for full retraction: 5 bar
 Maximum Braking Force full rate: 6.4kN
 Weight of caliper and thruster - 10.5kg
 Weight of thruster only - 3.5kg
 Volume displacement of thruster at full retraction = 950ml

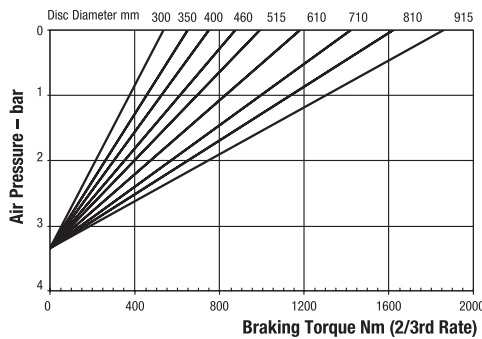

Minimum Pressure for full retraction: 3.3 bar
 Maximum Braking Force 2/3 rate: 4.3kN
 Weight of caliper and thruster - 10.5kg
 Weight of thruster only - 3.5kg
 Volume displacement of thruster at full retraction = 950ml

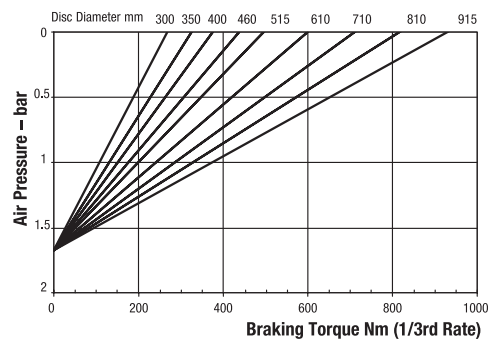

Minimum Pressure for full retraction: 1.7 bar
 Maximum Braking Force 1/3 rate: 2.2kN
 Weight of caliper and thruster - 10.5kg
 Weight of thruster only - 3.5kg
 Volume displacement of thruster at full retraction = 950ml

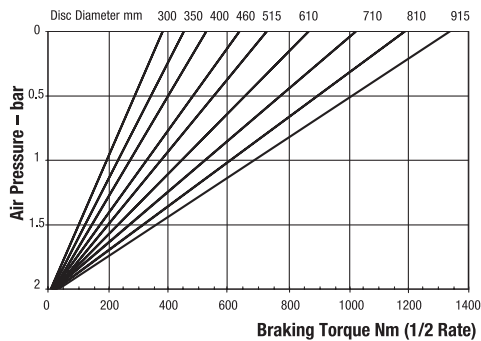

Minimum Pressure for full retraction: 2.5 bar
 Maximum Braking Force 1/2 rate: 3.2kN
 Weight of caliper and thruster - 10.5kg
 Weight of thruster only - 3.5kg
 Volume displacement of thruster at full retraction = 950ml

Retraction pressures where shown are calculated and may vary depending on spring tolerance.

MXL Spring Applied – Hydraulically Released, Self Adjusting

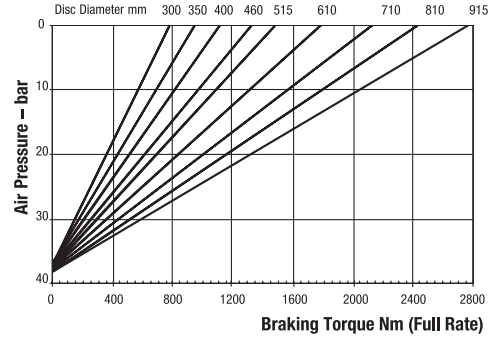
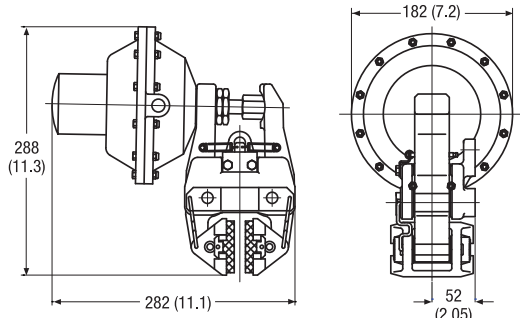

Minimum Pressure for full retraction: 50 bar
 Maximum Braking Force full rate: 6.4kN
 Weight of caliper and thruster - 11kg
 Weight of thruster only - 4.0kg
 Volume displacement of thruster at 4mm retraction = 5ml

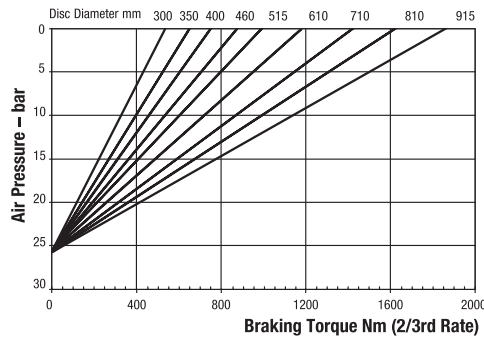

Minimum Pressure for full retraction: 33 bar
 Maximum Braking Force 2/3 rate: 4.3kN
 Weight of caliper and thruster - 11kg
 Weight of thruster only - 4.0kg
 Volume displacement of thruster at 4mm retraction = 5ml

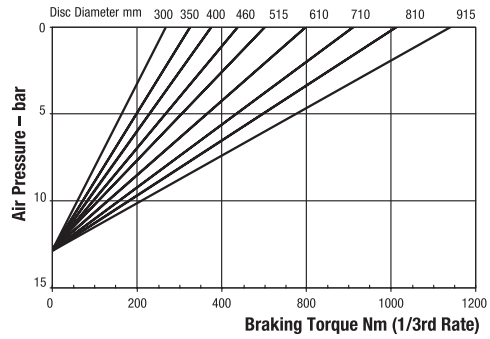

Minimum Pressure for full retraction: 17 bar
 Maximum Braking Force 1/3rd rate: 2.2kN
 Weight of caliper and thruster - 11kg
 Weight of thruster only - 4.0kg
 Volume displacement of thruster at 4mm retraction = 5ml

Retraction pressures where shown are calculated and may vary depending on spring tolerance.

GMX Series

GMX Disc Brake Caliper Range

The Twiflex GMX series of disc brake calipers is similar to the MX range but offers greater pad area. The GMX25, GMX30 and GMX40 are suitable for use with discs of 25.4mm, 30mm and 40mm thick respectively. The SGMX caliper is only suitable for use with discs 25.4mm thick. Minimum disc diameter is 610mm.

The GMX/SGMX calipers may be used with any of the Twiflex series of thrusters and feature a patented link mechanism to ensure uniform pad wear.

Normally one or two calipers are used per disc, but the number may be increased depending on disc size. The brakes may be positioned at any angle around the periphery of the disc, but should ideally be mounted horizontally (i.e. at

the 3 o'clock or 9 o'clock position). If the caliper mounting angle is greater than 10° from the horizontal, or on vertical shaft applications, it should be fitted with an inclined mounting kit or equalising link. A range of brake discs is available from Twiflex (see Disc and Hub Assemblies).

For pneumatic operation use dry, filtered and non-lubricated compressed air. Pneumatic brakes require a control valve, operated either manually or by pneumatic or electrical signal.

The ratings shown on the graphs are based on fully bedded in and conditioned brake pads with a nominal friction coefficient $\mu = 0.4$. Twiflex disc brakes must be used with Twiflex asbestos free brake pads.

Effective disc radius = actual radius (m) – 0.06m.

GMX Disc Brake Caliper

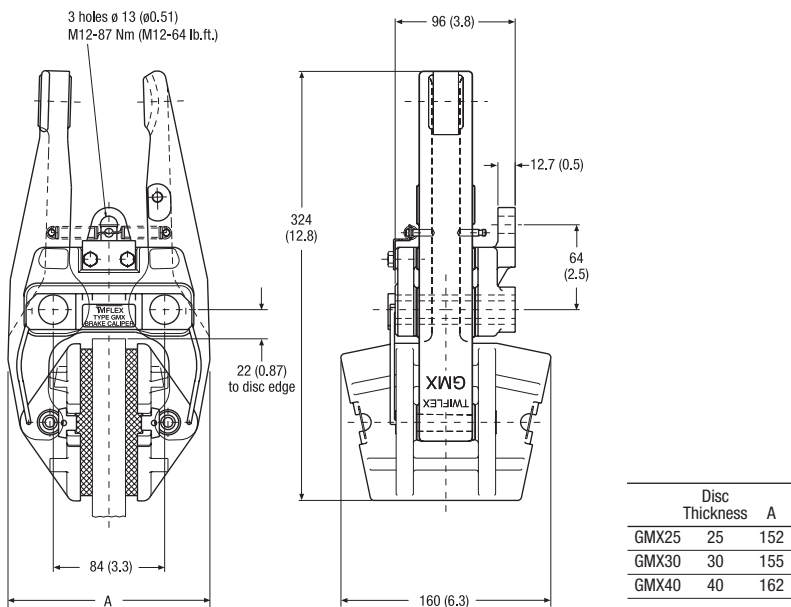

SGMX Disc Brake Caliper

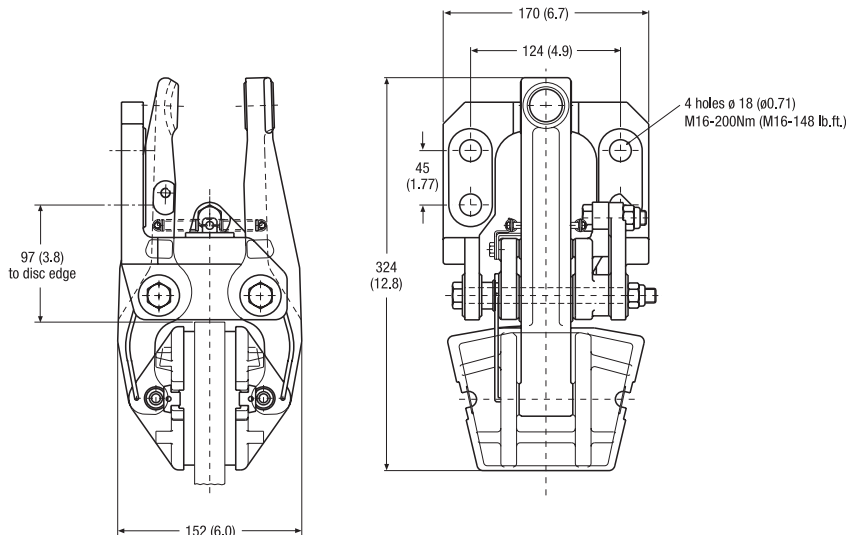

Retraction pressures where shown are calculated and may vary depending on spring tolerance.

GMXA Pneumatically Applied – Spring Released

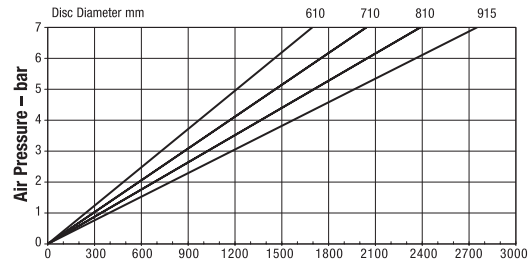
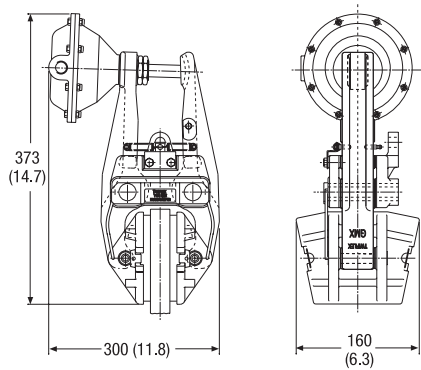

Maximum Pressure 7 bar
 Maximum Braking Force = 6.9kN @ 7 bar
 Weight of caliper and thruster - 10.54kg

Braking Torque Nm
 Weight of thruster only - 1.32kg
 Volume displacement of thruster at full stroke = 300ml

GMXB Pneumatically Applied – Spring Released

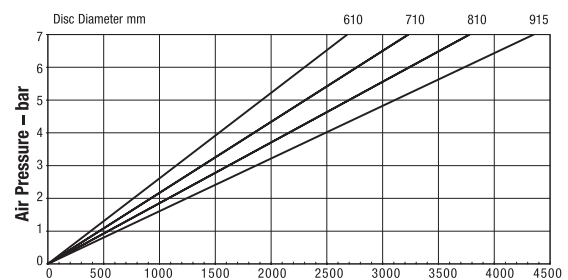
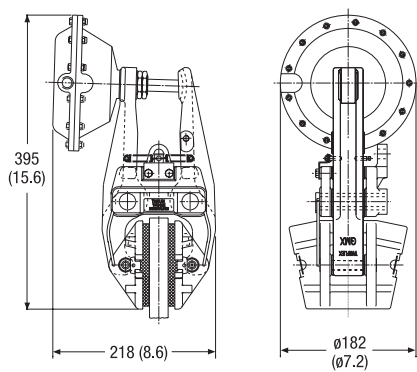

Maximum Pressure 7 bar
 Maximum Braking Force = 11kN @ 7 bar
 Weight of caliper and thruster - 11.28kg

Braking Torque Nm
 Weight of thruster only - 2.06kg
 Volume displacement of thruster at full stroke = 426ml

GMXD Pneumatically Applied – Spring Released

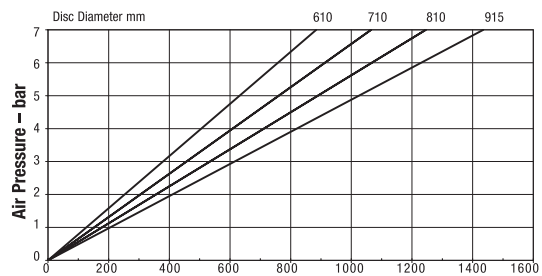
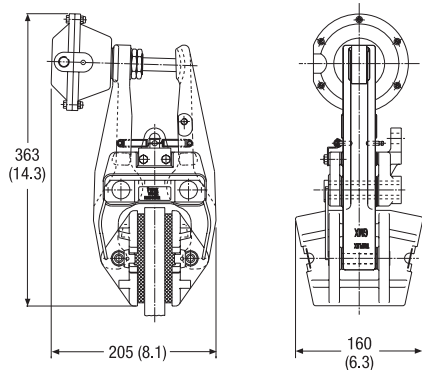

Maximum Pressure 7 bar
 Maximum Braking Force = 3.6kN @ 7 bar
 Weight of caliper and thruster - 10.37kg

Braking Torque Nm
 Weight of thruster only - 1.15kg
 Volume displacement of thruster at full stroke = 150ml

GMXE Pneumatically Applied – Spring Released

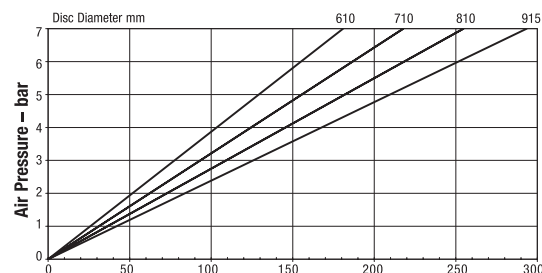
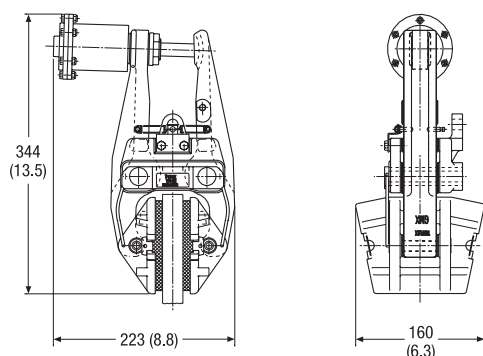

Maximum Pressure 7 bar
 Maximum Braking Force = 0.74kN @ 7 bar
 Weight of caliper and thruster - 9.56kg

Braking Torque Nm
 Weight of thruster only - 0.34kg
 Volume displacement of thruster at full stroke = 25ml

Retraction pressures where shown are calculated and may vary depending on spring tolerance.

GMX Series

GMXG Pneumatically Applied – Spring Released

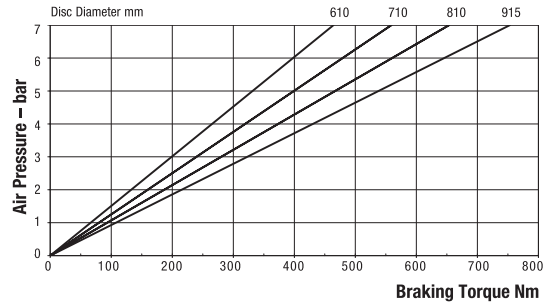
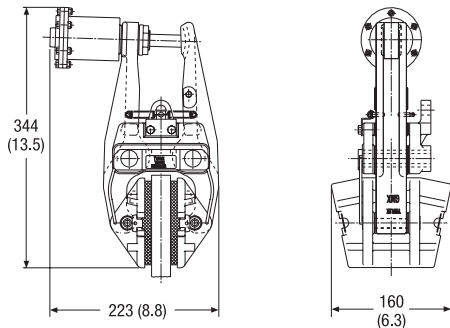

Maximum Pressure 7 bar
 Maximum Braking Force = 1.9kN @ 7 bar
 Weight of caliper and thruster - 9.52kg
 Weight of thruster only - 0.3kg
 Volume displacement of thruster at full stroke = 64ml

GMXH Mechanically Applied – Lever Operated

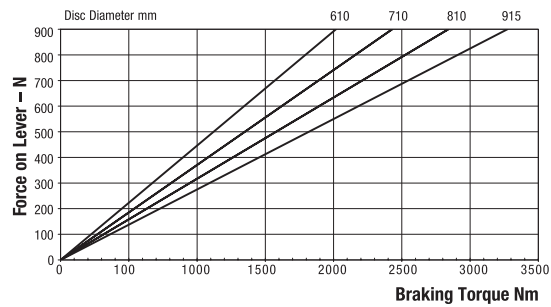
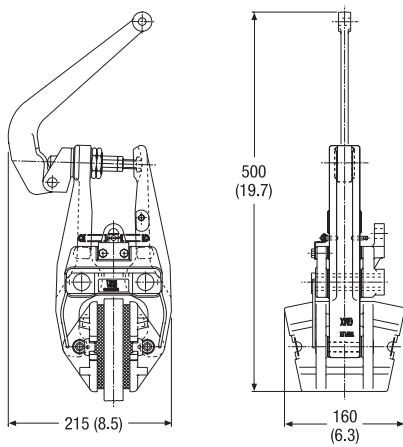

Weight of caliper and lever assembly - 10.62kg
 Weight of lever assembly only - 1.4kg
 Maximum Braking Force = 8.3kN @ 0.9kN force on lever

GMXW Mechanically Applied – Hand Operated

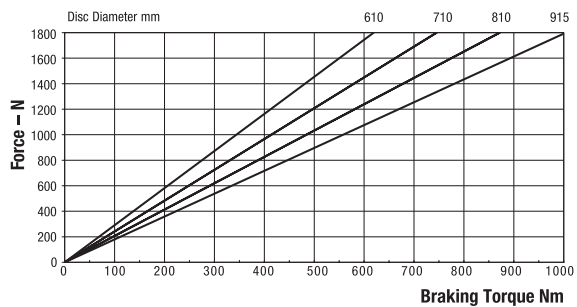
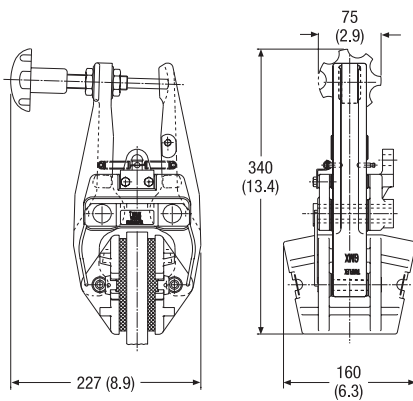

Weight of caliper and hand wheel assembly - 10.52kg
 Weight of hand wheel assembly only - 1.3kg
 Maximum Braking Force = 2.68kN

Retraction pressures where shown are calculated and may vary depending on spring tolerance.

GMXEA Spring Applied - Electrically Released, Self Adjusting

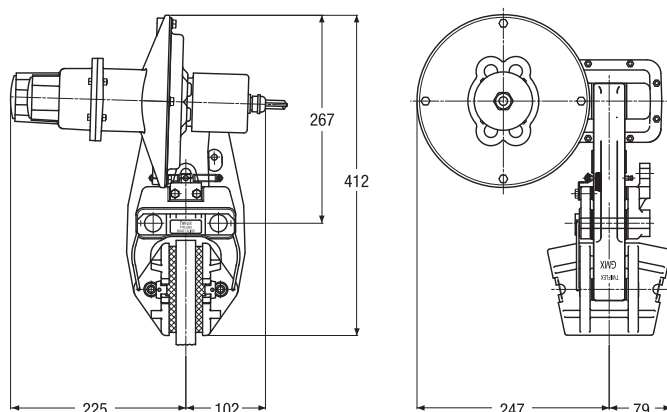

Maximum Braking Force = 6kN
Weight of caliper and actuator - 17.9kg

Weight actuator only - 8.7kg
Weight of controller - 5.5kg

The EA actuator is a spring applied, electrically released unit designed for use with the Twiflex GMX range of disc brake calipers. A 175W pancake motor drives a ball screw mechanism, retracting the brake.

A feature of the unit is a patented self-adjusting mechanism which maintains a constant air gap (and consequently braking force) between pad and disc as the pads wear.

The assembly is contained in a rugged, cast aluminum housing, designed for service in the harshest environments, which mounts directly to one arm of the GMX caliper.

The GMXEA is supplied complete with a solid state controller, suitable for all AC supply voltages, which converts the supply to the required DC output for the pancake motor. A 24VDC unit is also available. The brake is released when power to the controller is switched on, and applied when power is disconnected. Controlled application of the brake occurs, electrically damped by using the motor back E.M.F. and a damping resistor.

The controller is housed in a strong, steel, wall mounted enclosure (215mm x 215mm x 150mm deep), protected to IP44 as standard (higher rating on request).

Braking force adjustable to 50% of maximum.

GMX Series

GMXS Spring Applied – Pneumatically Released, Self Adjusting

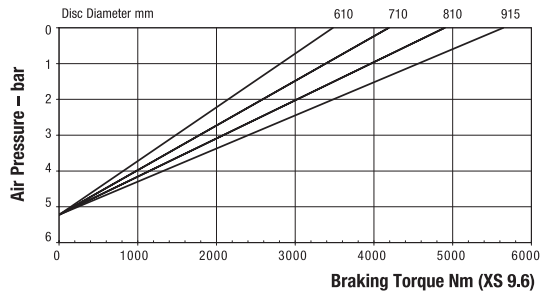
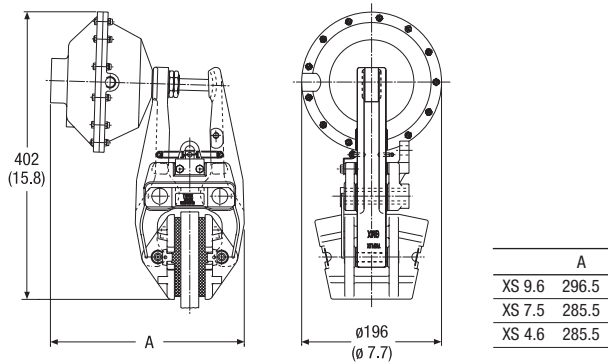

Braking Torque Nm (XS 9.6)
 Maximum Braking Force XS 9.6: 14.3kN
 Minimum Pressure for full retraction: 6.5 bar
 Weight of caliper and thruster - 14.32kg
 Weight of thruster only - 5.1kg
 Volume displacement of thruster at full retraction = 1.19 l

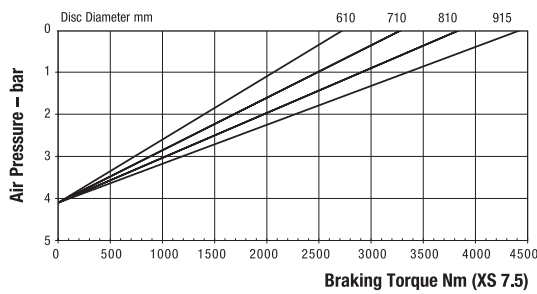

Braking Torque Nm (XS 7.5)
 Maximum Braking Force XS 7.5: 11.2kN
 Minimum Pressure for full retraction: 5 bar
 Weight of caliper and thruster - 14.12kg
 Weight of thruster only - 4.9kg
 Volume displacement of thruster at full retraction = 1.19 l

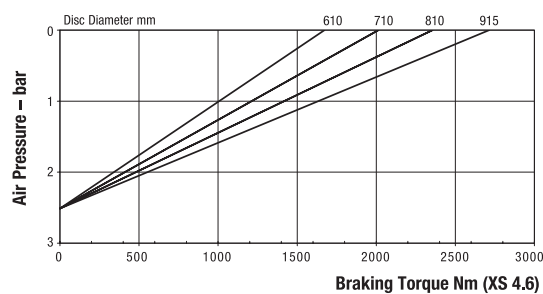

Braking Torque Nm (XS 4.6)
 Maximum Braking Force XS 4.6: 6.8kN
 Minimum Pressure for full retraction: 3 bar
 Weight of caliper and thruster - 13.72kg
 Weight of thruster only - 4.5kg
 Volume displacement of thruster at full retraction = 1.19 l

GMXSH Spring Applied – Hydraulically Released, Self Adjusting

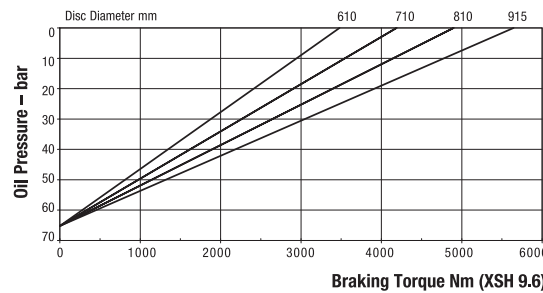
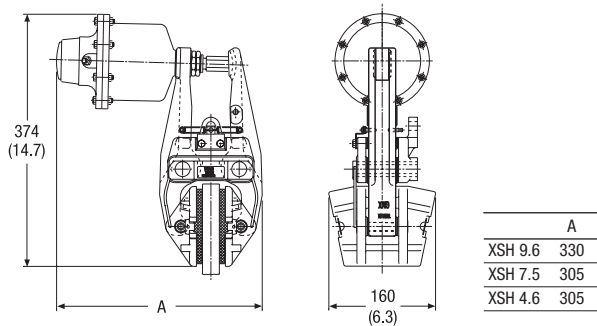

Braking Torque Nm (XSH 9.6)
 Maximum Braking Force XSH 9.6: 14.3kN
 Minimum Pressure for full retraction: 82 bar
 Weight of caliper and thruster - 13.82kg
 Weight of thruster only - 4.6kg
 Volume displacement of thruster at 6mm retraction = 9.1ml

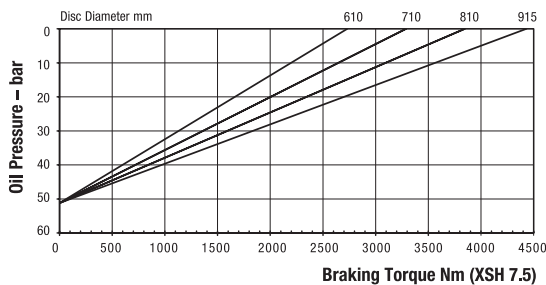

Braking Torque Nm (XSH 7.5)
 Maximum Braking Force XSH 7.5: 11.2kN
 Minimum Pressure for full retraction: 63 bar
 Weight of caliper and thruster - 13.62kg
 Weight of thruster only - 4.4kg
 Volume displacement of thruster at 6mm retraction = 9.1ml

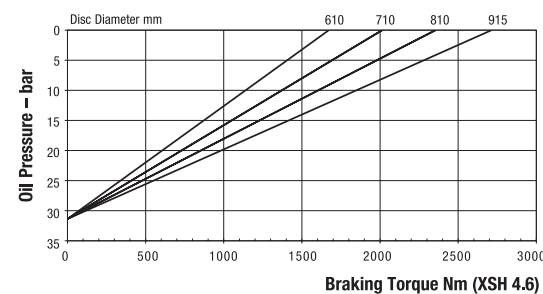

Braking Torque Nm (XSH 4.6)
 Maximum Braking Force XSH 4.6: 6.8kN
 Minimum Pressure for full retraction: 40 bar
 Weight of caliper and thruster - 13.22kg
 Weight of thruster only - 4kg
 Volume displacement of thruster at 6mm retraction = 9.1ml

Retraction pressures where shown are calculated and may vary depending on spring tolerance.

GMR Disc Brake Caliper

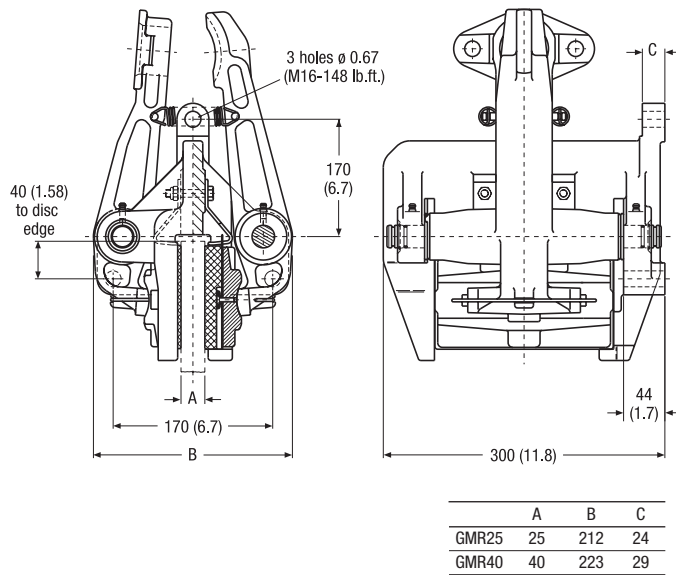

The Twiflex GMR and GMR40 series of disc brake calipers is suitable for use with discs of 25.4mm, and 40mm thick respectively. Minimum disc diameter is 610mm.

Normally one or two calipers are used per disc, but the number may be increased depending on disc size. The brakes may be positioned at any angle around the periphery of the disc, but should ideally be mounted horizontally (i.e. at the 3 o'clock or 9 o'clock position). If the caliper mounting angle is greater than 10° from the horizontal, or on vertical shaft applications, it should be fitted with an inclined mounting kit. A range of brake discs is available from Twiflex (see Disc and Hub Assemblies).

For pneumatic operation use dry, filtered and non-lubricated compressed air. Pneumatic brakes require a control valve, operated either manually or by pneumatic or electrical signal.

The ratings shown on the graphs are based on fully bedded in and conditioned brake pads with a nominal friction coefficient $\mu = 0.4$. Twiflex disc brakes must be used with Twiflex asbestos free brake pads.

Effective disc radius = actual radius (m) - 0.06m.

GMRP Pneumatically Applied – Spring Released

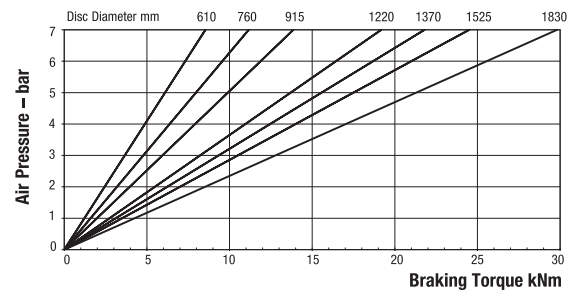
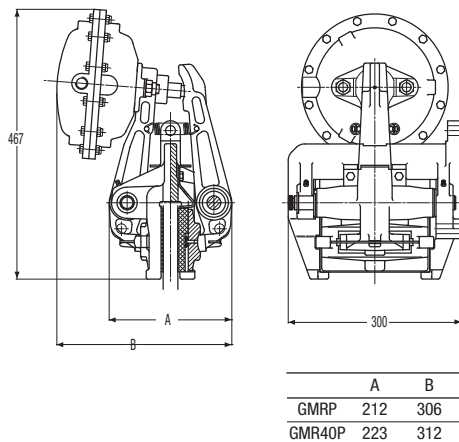

Maximum Pressure 7 bar
 Maximum Braking Force = 36kN @ 7 bar
 Weight of caliper and thruster - 40.8kg
 Weight of thruster only - 6.8kg
 Volume displacement of thruster at full stroke = 1.8 l

GMRH Hydraulically Applied – Spring Released

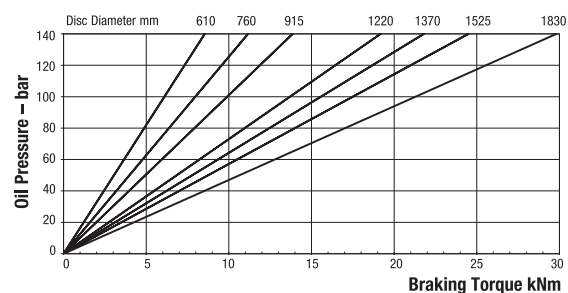
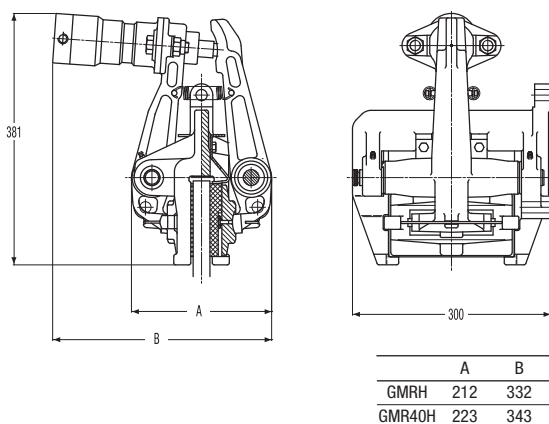

Maximum Pressure 140 bar
 Maximum Braking Force = 36kN @ 140 bar
 Weight of caliper and thruster - 36.9kg
 Weight of thruster only - 2.9kg
 Volume displacement of thruster at full stroke = 40ml

Retraction pressures where shown are calculated and may vary depending on spring tolerance.

GMR Series

GMRS Spring Applied – Pneumatically Released

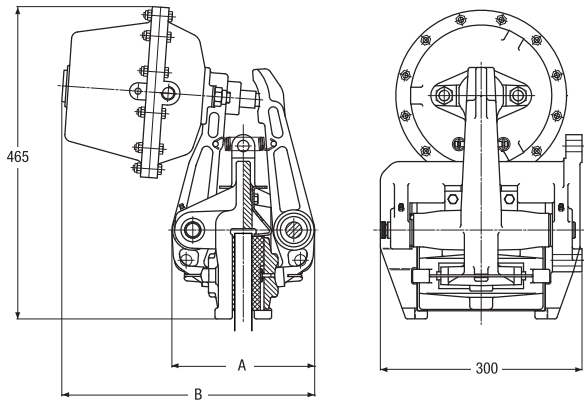

	A	B
GMRS	212	376
GMR40S	223	382

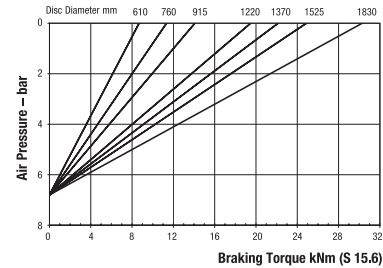

Maximum Braking Force S 15.6: 36kN
 Minimum Pressure for full retraction: 8.4 bar
 Weight of caliper and thruster - 49kg
 Weight of thruster only - 15kg
 Volume displacement of thruster at full retraction = 1.3 l

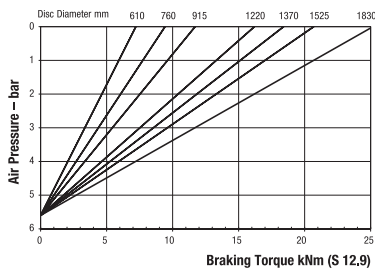

Maximum Braking Force S 12.9: 30kN
 Minimum Pressure for full retraction: 7 bar
 Weight of caliper and thruster - 48kg
 Weight of thruster only - 14kg
 Volume displacement of thruster at full retraction = 1.3 l

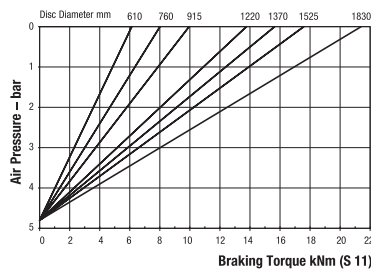

Maximum Braking Force S 11: 25kN
 Minimum Pressure for full retraction: 6 bar
 Weight of caliper and thruster - 47.2kg
 Weight of thruster only - 13.2kg
 Volume displacement of thruster at full retraction = 1.3 l

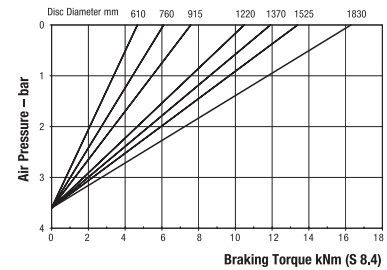

Maximum Braking Force S 8.4: 19.5kN
 Minimum Pressure for full retraction: 4.8 bar
 Weight of caliper and thruster - 46.2kg
 Weight of thruster only - 12.2kg
 Volume displacement of thruster at full retraction = 1.3 l

GMRSD Spring Applied – Pneumatically Released

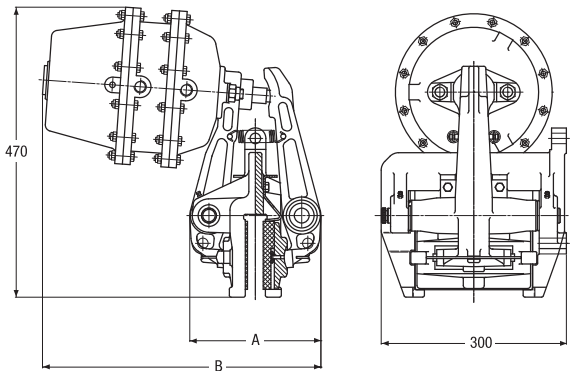

	A	B
GMRSD	212	451
GMR40SD	223	457

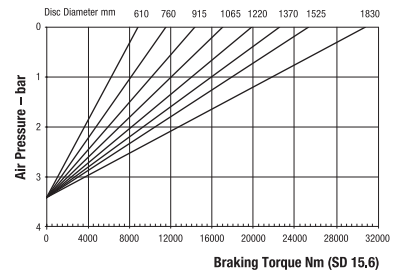

Maximum Braking Force SD 15.6: 36kN
 Minimum Pressure for full retraction: 4.6 bar
 Weight of caliper and thruster - 55kg
 Weight of thruster only - 21kg
 Volume displacement of thruster at full retraction = 2.5 l

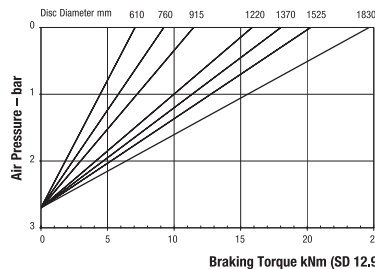

Maximum Braking Force SD 12.9: 30kN
 Minimum Pressure for full retraction: 3.8 bar
 Weight of caliper and thruster - 54kg
 Weight of thruster only - 20kg
 Volume displacement of thruster at full retraction = 2.5 l

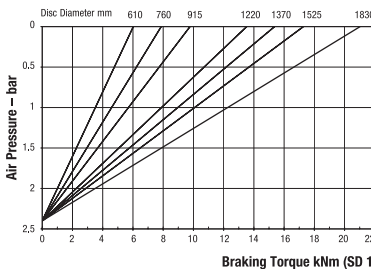

Maximum Braking Force SD 11: 25kN
 Minimum Pressure for full retraction: 3.3 bar
 Weight of caliper and thruster - 53.2kg
 Weight of thruster only - 19.2kg
 Volume displacement of thruster at full retraction = 2.5 l

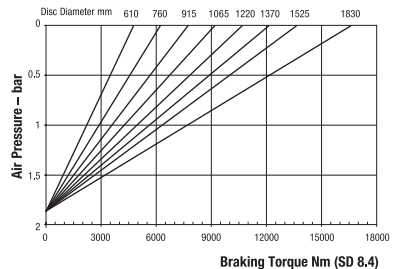

Maximum Braking Force SD 8.4: 19.5kN
 Minimum Pressure for full retraction: 2.4 bar
 Weight of caliper and thruster - 52.2kg
 Weight of thruster only - 18.2kg
 Volume displacement of thruster at full retraction = 2.5 l

Retraction pressures where shown are calculated and may vary depending on spring tolerance.

GMRSH Spring Applied – Hydraulically Released

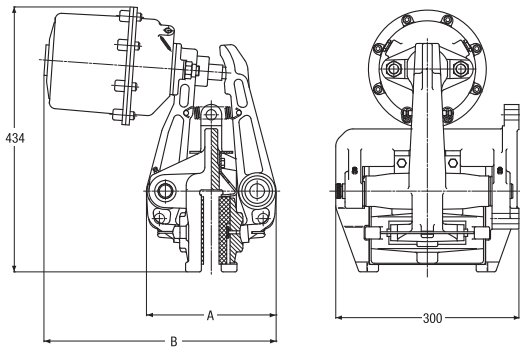

	A	B
GMRSH	212	380
GMR40SH	223	387

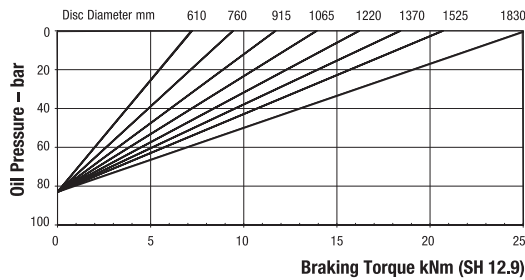

Maximum Braking Force SH 12.9: 30kN
 Minimum Pressure for full retraction: 100 bar
 Weight of caliper and thruster - 52kg
 Weight of thruster only - 18kg
 Volume displacement of thruster at full retraction = 56ml

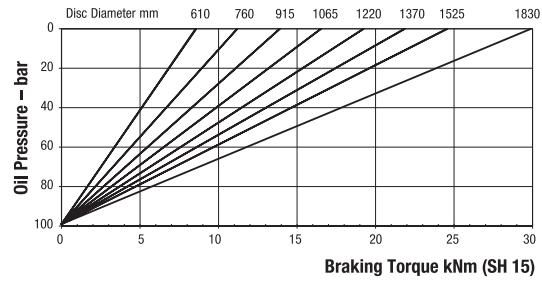

Maximum Braking Force SH 15: 35kN
 Minimum Pressure for full retraction: 120 bar
 Weight of caliper and thruster - 53kg
 Weight of thruster only - 19kg
 Volume displacement of thruster at full retraction = 56ml

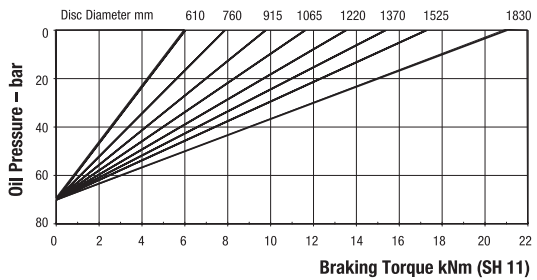

Maximum Braking Force SH 11: 25kN
 Minimum Pressure for full retraction: 92 bar
 Weight of caliper and thruster - 51.2kg
 Weight of thruster only - 17.2kg
 Volume displacement of thruster at full retraction = 56ml

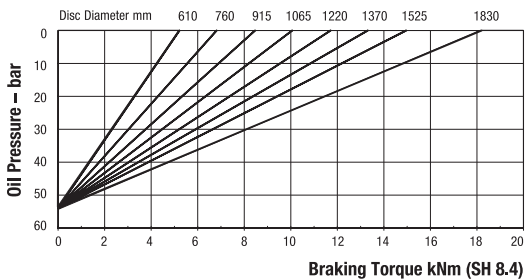

Maximum Braking Force SH 8.4: 19.5kN
 Minimum Pressure for full retraction: 65 bar
 Weight of caliper and thruster - 50.2kg
 Weight of thruster only - 16.2kg
 Volume displacement of thruster at full retraction = 56ml

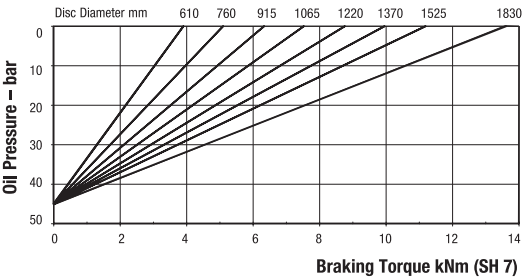

Maximum Braking Force SH 7: 16.5kN
 Minimum Pressure for full retraction: 59 bar
 Weight of caliper and thruster - 49.7kg
 Weight of thruster only - 15.7kg
 Volume displacement of thruster at full retraction = 56ml

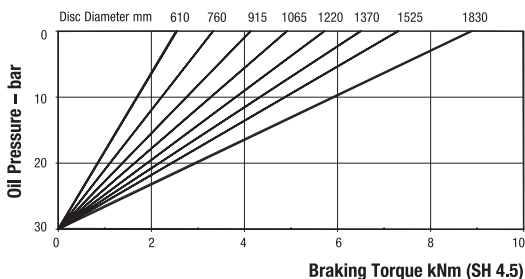

Maximum Braking Force SH 4.5: 10.5kN
 Minimum Pressure for full retraction: 38 bar
 Weight of caliper and thruster - 48.7kg
 Weight of thruster only - 14.7kg
 Volume displacement of thruster at full retraction = 56ml

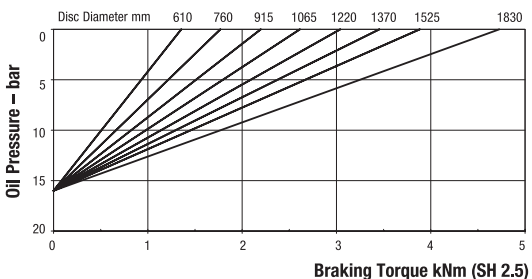

Maximum Braking Force SH 2.5: 6kN
 Minimum Pressure for full retraction: 21 bar
 Weight of caliper and thruster - 47.9kg
 Weight of thruster only - 13.9kg
 Volume displacement of thruster at full retraction = 56ml

Retraction pressures where shown are calculated and may vary depending on spring tolerance.

Modular Series

T2 Pneumatically or Hydraulically Applied

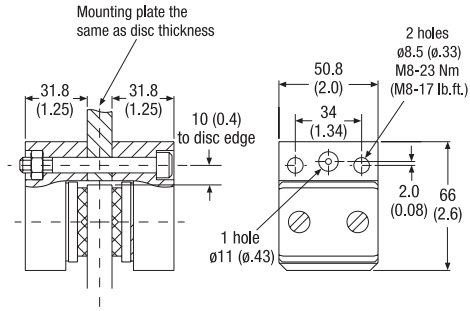

The Twiflex T2 disc brake caliper is split caliper design suitable for use with a minimum disc thickness of 5mm. The modules are mounted each side of a central mounting plate of the same thickness as the brake disc. Minimum disc diameter is 120mm. Alternatively, the brake may be side-mounted with a spacer equal to the disc thickness between the two halves.

For pneumatic operation, use dry and filtered compressed air. Pneumatic brakes require a control valve, operated either manually or by pneumatic or electrical signal.

Normally one or two calipers are used per disc, but the number may be increased depending on disc size. The brakes may be positioned at

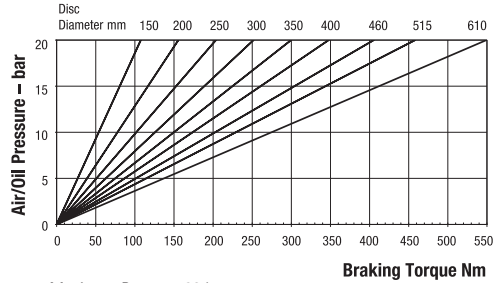

Maximum Pressure 20 bar
 Maximum Braking Force = 2kN @ 20 bar oil or air pressure
 Weight of caliper - 0.75kg
 Volume displacement per 1mm stroke at each pad = 3ml

any angle around the periphery of the disc, but should ideally be mounted horizontally (i.e. at the 3 o'clock or 9 o'clock position). A range of brake discs is available from Twiflex (see Disc and Hub Assemblies).

The ratings shown on the graph are based on fully bedded in and conditioned brake pads with a nominal friction coefficient $\mu = 0.4$. Twiflex disc brakes must be used with Twiflex asbestos free brake pads.

Effective disc radius = actual radius (m) - 0.019m.

T20 Hydraulically Applied

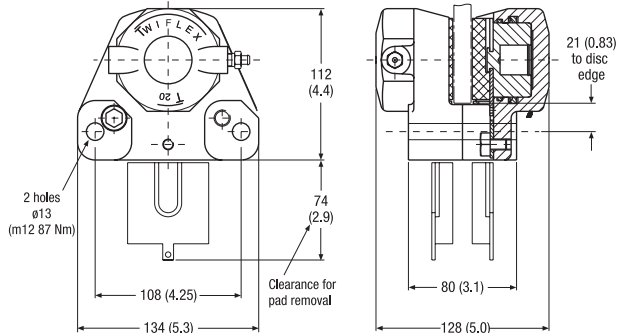

The standard Twiflex T20 disc brake caliper is split caliper design suitable for use with a minimum disc thickness of 12.7mm. Optionally, the caliper may be supplied in a modified form for use with a minimum disc thickness of 8mm. Normally the brake is side mounted, however, for use with a disc thickness greater than 20mm, the split design allows the modules to be mounted each side of a central mounting plate of the same thickness as the brake disc. Minimum disc diameter is 300mm.

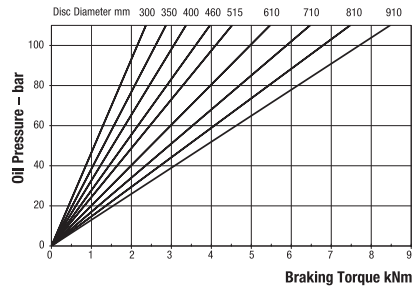

Maximum Pressure 110 bar
 Maximum Braking Force = 20kN @ 110 bar
 Weight of caliper - 5.82kg
 Volume displacement per 1mm stroke at each pad = 4.8ml

Normally one or two calipers are used per disc, but the number may be increased depending on disc size. The brakes may be positioned at any angle around the periphery of the disc. A range of brake discs is available from Twiflex (see Disc and Hub Assemblies).

The ratings shown on the graph are based on fully bedded in and conditioned brake pads with a nominal friction coefficient $\mu = 0.4$. Twiflex disc brakes must be used with Twiflex asbestos free brake pads. Effective disc radius = actual radius (m) - 0.032m.

Retraction pressures where shown are calculated and may vary depending on spring tolerance.

T40 Hydraulically Applied

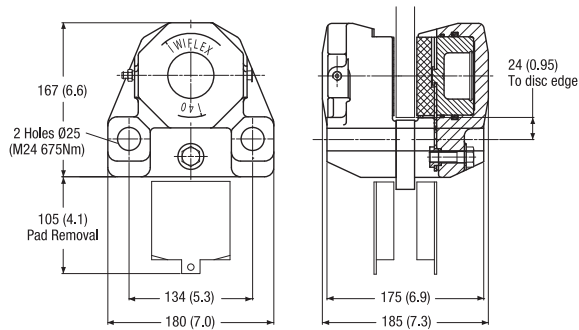

The Twiflex T40 disc brake caliper is split caliper design suitable for use with a minimum disc thickness of 20mm. The modules are mounted each side of a central mounting plate of the same thickness as the brake disc. Minimum disc diameter is 300mm.

Normally one or two calipers are used per disc, but the number may be increased depending on disc size. The brakes may be positioned

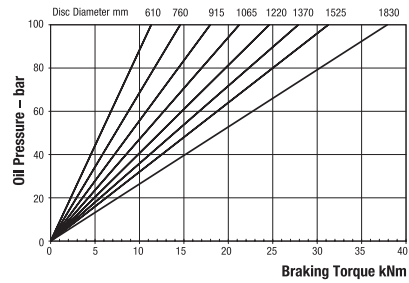

Maximum Pressure 100 bar
 Maximum Braking Force = 45kN @ 100 bar
 Weight of caliper - 18.6kg
 Volume displacement per 1mm stroke at each pad = 15ml

at any angle around the periphery of the disc. A range of brake discs is available from Twiflex (see Disc and Hub Assemblies).

The ratings shown on the graph are based on fully bedded in and conditioned brake pads with a nominal friction coefficient $\mu = 0.4$. Twiflex disc brakes must be used with Twiflex asbestos free brake pads. Effective disc radius = actual radius (m) - 0.045m.

Modular Series

VCSMk4 Spring Applied – Hydraulically Released

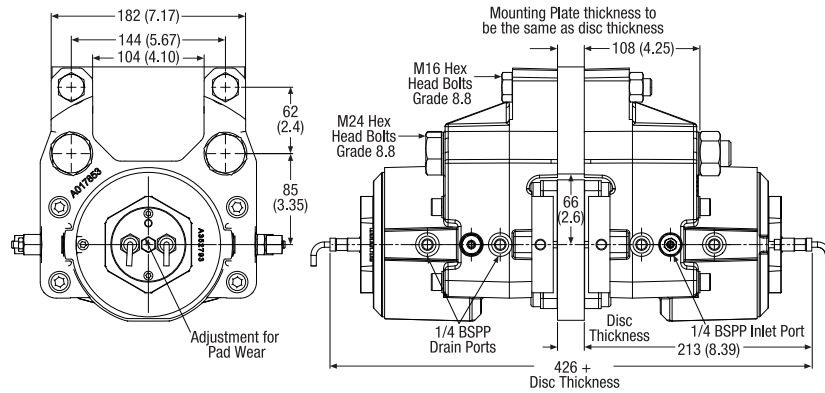

Caliper Type	Disc/Pad Air Gap mm	Braking Force kN	Minimum Pressure for Full Retraction bar
VCS70	1.7	62	160
VCS60	2.0	53	148
VCS50	2.0	44	131
VCS40	2.0	35	113
VCS30	2.0	25	94

Weight of caliper (2 modules) - 50kg
Volume displacement per 1mm stroke at both pads = 21ml

The Twiflex VCS Mk4 disc brake caliper is comprised of two halves, or spring modules, and is suitable for use with a minimum disc thickness of 20mm. The modules are mounted each side of a central mounting plate of the same thickness as the brake disc. Minimum disc diameter is 500mm.

Normally one or two calipers are used per disc, but the number may be increased depending on disc size. The brakes may be positioned at any angle around the periphery of the disc, but should ideally be mounted horizontally (i.e. at the 3 o'clock or 9 o'clock position). A range of brake discs is available from Twiflex (see Disc and Hub Assemblies).

Braking force ratings are achieved through a combination of shim number and air gap setting. Spring fatigue life is a function of the caliper rating.

The ratings shown in the table are based on fully bedded in and conditioned brake pads with a nominal friction coefficient $\mu = 0.4$. Twiflex disc brakes must be used with Twiflex asbestos free brake pads.

Effective disc radius = actual radius (m) – 0.064m.

VCS-FL Spring Applied – Hydraulically Released

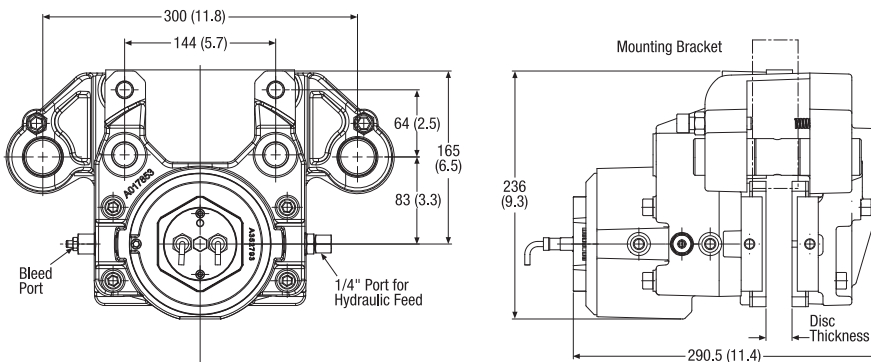

The Twiflex VCS-FL disc brake caliper comprises a single spring module forming the 'active' side of this floating unit and is available for use where space is limited or to accommodate axial disc float of ± 6 mm.

Braking force ratings are achieved through a combination of shim number and air gap setting. Spring fatigue life is a function of the caliper rating.

The ratings shown in the table are based on fully bedded in and conditioned brake pads with a nominal friction coefficient $\mu = 0.4$. Twiflex disc brakes must be used with Twiflex asbestos free brake pads.

Effective disc radius = actual radius (m) – 0.064m.

VKSD Spring Applied – Hydraulically Released

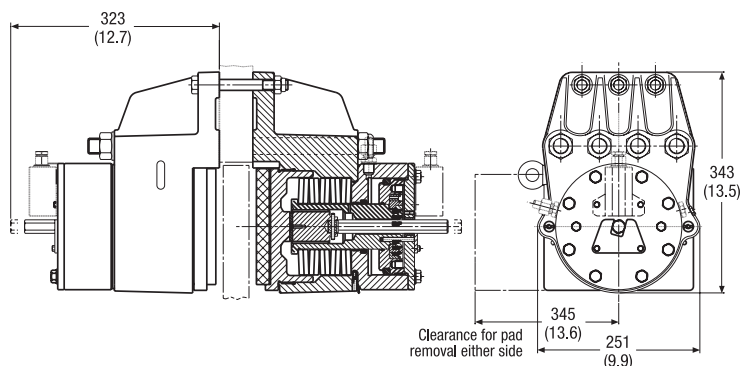

The Twiflex VKSD disc brake caliper is comprised of two halves, or spring modules, and is suitable for use with a minimum disc thickness of 20mm. The modules are mounted each side of a central mounting plate 12mm thicker than the brake disc. Minimum disc diameter is 1000mm.

Normally one or two calipers are used per disc, but the number may be increased depending on disc size. The brakes may be positioned at any angle around the periphery of the disc, but should ideally be mounted horizontally (i.e. at the 3 o'clock or 9 o'clock position). A range of brake discs is available from Twiflex (see Disc and Hub Assemblies).

Braking force ratings are achieved through a combination of different springs, shims and air gap settings. Spring fatigue life is a function of the caliper rating.

The ratings shown in the table are based on fully bedded in and conditioned brake pads with a nominal friction coefficient $\mu = 0.4$. Twiflex disc brakes must be used with Twiflex asbestos free brake pads.

Effective disc radius = actual radius (m) – 0.095m.

Caliper Type	Disc/Pad Air Gap mm	Braking Force kN	Minimum Pressure for Full Retraction bar
VKSD119	2	119	138
VKSD112	2	112	131
VKSD104	2	104	124
VKSD96	2	96	116
VKSD88	2	88	108
VKSD80	2	80	100
VKSD71	2	71	92
VKSD62	2	62	83
VKSD58	2	58	63
VKSD53	2	53	58
VKSD47	2	47	53
VKSD41	2	41	47
VKSD34	2	34	41
VKSD28	2	28	34

Weight of caliper (2 modules) - 146kg
Volume displacement per 1mm stroke at both pads = 28ml

VKSD-FL Spring Applied – Hydraulically Released

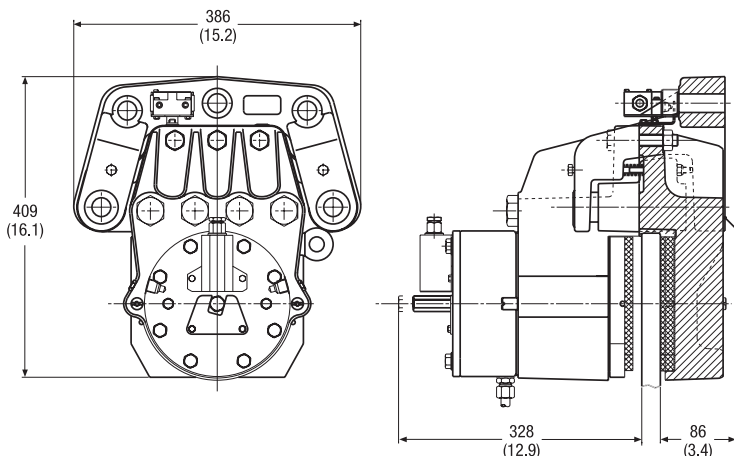

The Twiflex VKSD-FL disc brake caliper comprises a single spring module forming the 'active' side of this floating unit and is available for use where space is limited or to accommodate axial disc float of ± 6 mm.

Braking force ratings are achieved through a combination of different springs, shims and air gap settings. Spring fatigue life is a function of the caliper rating.

The ratings shown in the table are based on fully bedded in and conditioned brake pads with a nominal friction coefficient $\mu = 0.4$. Twiflex disc brakes must be used with Twiflex asbestos free brake pads.

Effective disc radius = actual radius (m) – 0.095m.

Retraction pressures where shown are calculated and may vary depending on spring tolerance.

Modular Series

VKHD Hydraulically Applied – Spring Released

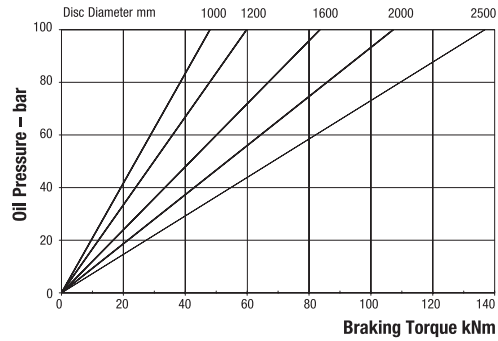
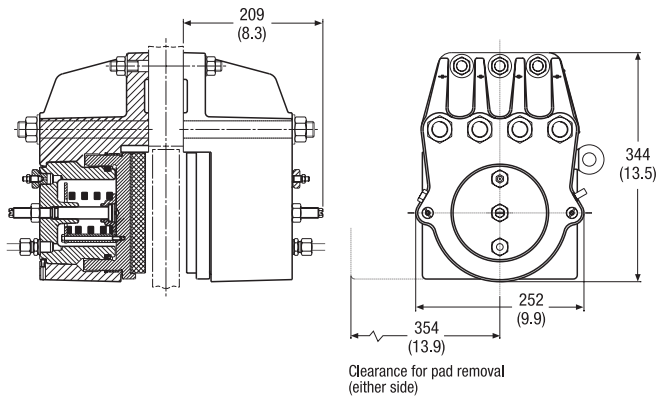

Maximum Pressure 100 bar
 Maximum Braking Force = 118kN @ 100 bar
 Weight of caliper (2 modules) - 80kg
 Volume displacement per 1mm stroke at both pads = 31ml

The Twiflex VKHD disc brake caliper is comprised of two halves, or hydraulic modules, and is suitable for use with a minimum disc thickness of 20mm. The modules are mounted each side of a central mounting plate 12mm thicker than the brake disc. Minimum disc diameter is 1000mm.

Normally one or two calipers are used per disc, but the number may be increased depending on disc size. The brakes may be positioned at any angle around the periphery of the disc, but should ideally be mounted horizontally (i.e. at the 3

o'clock or 9 o'clock position). A range of brake discs is available from Twiflex (see Disc and Hub Assemblies).

The ratings shown on the graph are based on fully bedded in and conditioned brake pads with a nominal friction coefficient $\mu = 0.4$. Twiflex disc brakes must be used with Twiflex asbestos free brake pads.

Effective disc radius = actual radius (m) – 0.095m.

VSMk2 Spring Applied – Hydraulically Released

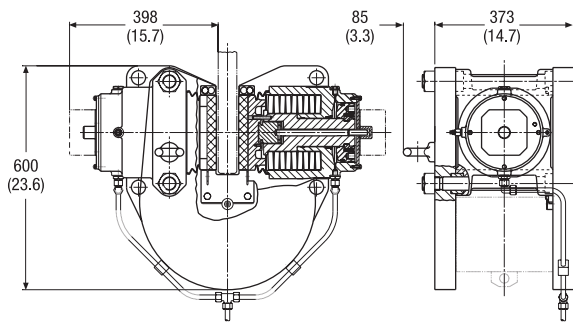

The Twiflex VS Mk2 disc brake caliper is comprised of two modules secured between U-shaped top and bottom mounting plates by tie rods.

Typically one or two calipers are used per disc, but the number may be increased depending on disc size. The brakes may be positioned at any angle around the periphery, but ideally mounted horizontally (at the 3 o'clock or 9 o'clock positions).

Minimum disc diameter is 1000mm with no maximum except for practical limitations. The standard caliper can

Caliper Type	Disc/Pad Air Gap mm	Braking Force kN	Minimum Pressure for Full Retraction bar
VS230	4	185	180
VS205	4	165	163
VS190	4	153	154
VS175	4	141	144
VS155	4	125	131
VS137	4	111	108
VS100	4	81	84

Weight of caliper = 410kg
 Volume displacement per 1mm stroke at both pads = 32ml

accommodate disc thicknesses from 38mm to 50mm - consult Twiflex for discs thicker than 50mm.

A tandem caliper arrangement is available sharing a common, central, mounting plate; minimum disc diameter is 2000mm

The ratings shown on the tables are based on fully bedded in and conditioned brake pads with a nominal friction coefficient $\mu = 0.4$. Twiflex disc brakes must be used with Twiflex asbestos free brake pads.

Effective disc radius = actual radius (m) – 0.110m.

Note: Spring fatigue life is a function of the caliper rating.

VH Hydraulically Applied – Spring Released

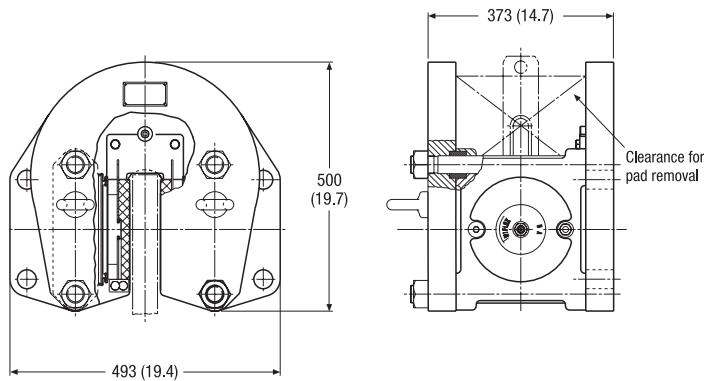

The Twiflex VH disc brake caliper is comprised of two modules secured between U-shaped top and bottom mounting plates by tie rods.

Typically one or two calipers are used per disc, but the number may be increased depending on disc size. The brakes may be positioned at any angle around the periphery, but ideally mounted horizontally (at the 3 o'clock or 9 o'clock positions).

Minimum disc diameter is 1000mm with no maximum except for practical limitations. The standard caliper can

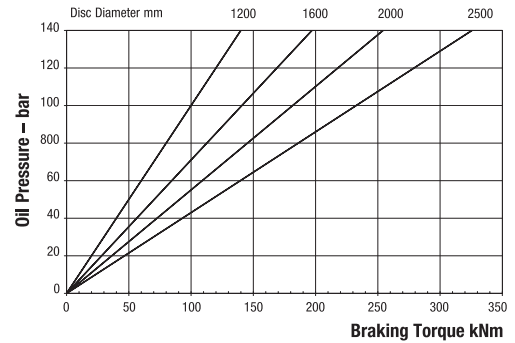

Maximum Pressure 140 bar
 Maximum Braking Force = 285kN @ 140 bar
 Weight of caliper - 287kg
 Volume displacement per 1mm stroke at both pads = 51.7ml

accommodate disc thicknesses from 38mm to 50mm - consult Twiflex for discs thicker than 50mm.

A tandem caliper arrangement is available sharing a common, central, mounting plate; minimum disc diameter is 2000mm

The ratings shown on the graph are based on fully bedded in and conditioned brake pads with a nominal friction coefficient $\mu = 0.4$. Twiflex disc brakes must be used with Twiflex asbestos free brake pads.

Effective disc radius = actual radius (m) - 0.110m.

VMH2 Hydraulically Applied – Spring Released

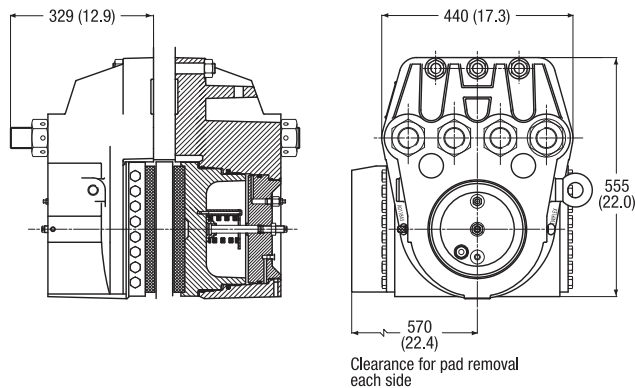

The Twiflex VMH2 disc brake caliper is comprised of two modules bolted to a central mounting plate, 12mm thicker than the brake disc. Minimum disc thickness is 38mm and minimum disc diameter is 1500mm with no maximum except for practical limitations.

Typically one or two calipers are used per disc, positioned at any angle around the periphery, but the number may be increased depending on disc size.

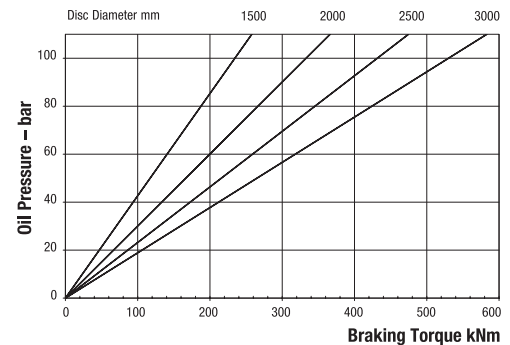

Maximum Pressure 110 bar
 Maximum Braking Force = 433kN @ 110 bar
 Weight of caliper (2 modules) - 580kg
 Volume displacement per 1mm stroke at both pads = 101.5ml

The ratings shown on the graph are based on fully bedded in and conditioned brake pads with a nominal friction coefficient $\mu = 0.4$. Twiflex disc brakes must be used with Twiflex asbestos free brake pads.

Effective disc radius = actual radius (m) - 0.155m.

Retraction pressures where shown are calculated and may vary depending on spring tolerance.

Modular Series

VMS3SPS Spring Applied – Hydraulically Released

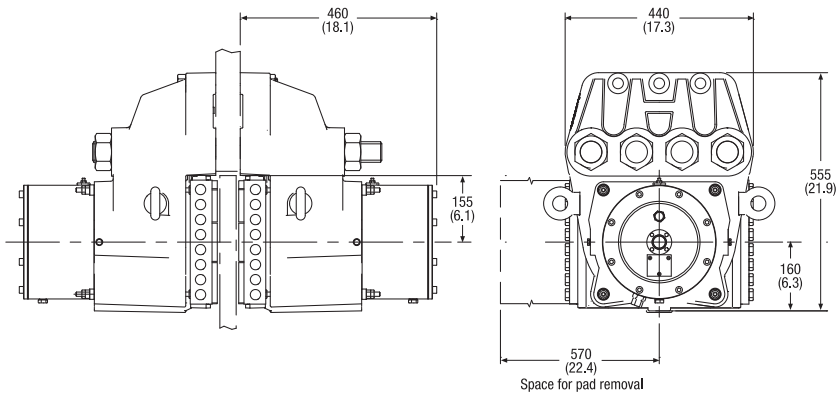

The Twiflex VMS3-SPS disc brake caliper is comprised of two modules bolted to a central mounting plate, 12mm thicker than the brake disc. Minimum disc thickness is 38mm and minimum disc diameter is 1500mm with no maximum except for practical limitations. Based on a development of the earlier Twiflex VMS2-SP disc brake, the VMS3-SPS provides a significant increase in braking force but in a similarly sized package.

Infinite fatigue life ($>2 \times 10^6$ cycles) is achievable for most units at the 3mm air gap shown in the table and possible, by reducing this setting, for the higher rated brakes – contact Twiflex for further information.

The braking force is a function of both the air-gap setting and the thickness of the shim pack (if used) but may be also controlled using hydraulic back pressure during braking.

The ratings shown on the tables are based on fully bedded in and conditioned brake pads with a nominal friction coefficient $\mu = 0.4$. Twiflex disc brakes must be used with Twiflex asbestos free brake pads.

Effective disc radius = actual radius (m) – 0.155m.

Caliper Type	Disc/Pad Air Gap mm	Braking Force kN	Minimum Pressure for Full Retraction bar
VMS3 SPS276	3	276	158
VMS3 SPS268	3	268	154
VMS3 SPS260	3	260	149
VMS3 SPS252	3	252	145
VMS3 SPS244	3	244	141
VMS3 SPS236	3	236	137
VMS3 SPS227	3	227	132
VMS3 SPS219	3	219	128
VMS3 SPS211	3	211	124
VMS3 SPS202	3	202	119
VMS3 SPS194	3	194	115
VMS3 SPS185	3	185	110
VMS3 SPS177	3	177	106
VMS3 SPS168	3	168	101
VMS3 SPS159	3	159	96
VMS3 SPS150	3	150	91
VMS3 SPS141	3	141	87

Weight of Caliper (2 Modules) = 675kg
Volume displacement per 1mm stroke at both pads = 52ml

VMS2 Spring Applied – Hydraulically Released

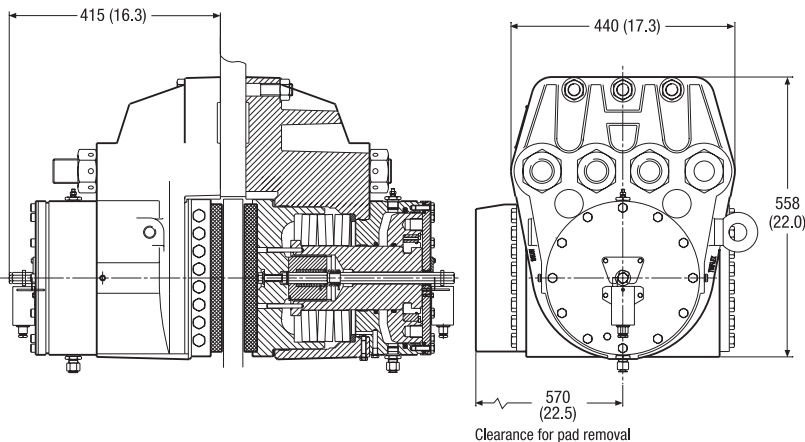

The Twiflex VMS2 disc brake caliper is comprised of two modules bolted to a central mounting plate, 12mm thicker than the brake disc. Minimum disc thickness is 38mm and minimum disc diameter is 1500mm with no maximum except for practical limitations.

Typically one or two calipers are used per disc, positioned at any angle around the periphery, but the number may be increased depending on disc size.

The braking force is a function of both the air-gap setting and the thickness of the shim pack used (see table) but may be also controlled using hydraulic back pressure during braking.

The ratings shown on the tables are based on fully bedded in and conditioned brake pads with a nominal friction coefficient $\mu = 0.4$. Twiflex disc brakes must be used with Twiflex asbestos free brake pads.

Effective disc radius = actual radius (m) – 0.155m.

Caliper Type	Disc/Pad Air Gap mm	Braking Force kN	Hydraulic Pressure for Full Retraction bar
VMS392	3	392	210
VMS356	3	356	197
VMS320	3	320	184
VMS283	3	283	167
VMS245	3	245	154
VMS206	3	206	138
VMS167	3	167	122

Weight of Caliper (2 Modules) = 670kg
Volume displacement per 1mm stroke at both pads = 77ml

Retraction pressures where shown are calculated and may vary depending on spring tolerance.

VMSDP Spring Applied – Hydraulically Released

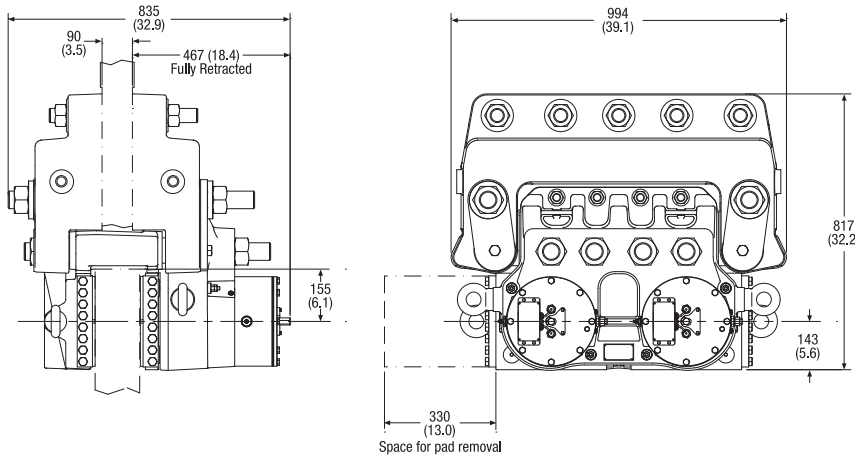

Shim Pack	Braking Force kN	Minimum Pressure for Full Retraction bar	Spring Life Cycles
0	590	169	>100000
1	639	181	>100000
2	688	192	>20000
3	737	204	>20000

Weight of caliper = 1887Kg
Volume displacement per 2mm stroke = 174ml

Similar to the Twiflex VMS2 disc brake, the VMS-DP comprises 2 spring modules; this time mounted in a common housing to form the 'active' side of a floating brake caliper. This arrangement allows the assembly to accommodate ± 10 mm of axial disc movement.

Minimum disc diameter is 4500mm with no maximum except for practical limitations. Disc thickness for the standard caliper range from 117mm to 130mm with the mounting bracket being machined accordingly.

The braking force is a function of both the air-gap setting and the thickness of the shim pack used (see table) but may be also controlled using hydraulic back pressure during braking.

The VMS-DP is primarily intended to function as a holding brake, but may be used for a dynamic duty where spring life is not a consideration (for example, occasional emergency stopping).

The ratings shown in the table are based on fully bedded in and conditioned brake pads with a nominal friction coefficient $\mu = 0.4$. Twiflex disc brakes must be used with Twiflex asbestos free brake pads.

Effective disc radius = actual radius (m) – 0.155m.

Retraction pressures where shown are calculated and may vary depending on spring tolerance.

Disc and Hub Assemblies

Brake Discs

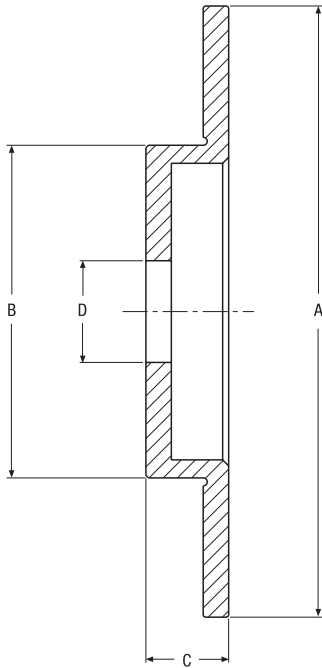

Twiflex brake discs may be supplied bored and drilled to customer requirements. Non-standard disc sizes, not shown in the tables, can be supplied to order. Brake discs are manufactured from spheroidal graphite iron.

12.7mm thick brake discs

Nominal Diameter	A	B	C	D Min.	Inertia kgm ²	Weight kg	Max. Safe Disc Speed
250	250	128	36	30	0.04	4.0	6500
300	305	166	41	51	0.09	7.3	6000
350	356	210	54	76	0.17	10.9	5100
400	406	260	54	102	0.28	14.1	4400
460	457	311	54	102	0.48	19.1	3900
515	514	368	54	102	0.75	22.7	3500
610	610	464	54	102	1.57	33.0	2900
710	711	565	54	102	3.20	52.3	2500
810	813	660	54	102	6.57	85.5	2200
915	914	762	54	102	10.80	110.9	1900

All dimensions in mm

25.4mm thick brake discs

Nominal Diameter	A	B	C	D Min.	Inertia kgm ²	Weight kg	Max. Safe Disc Speed
610	610	343	76	125	2.75	66	2900
760	762	495	76	125	7.0	104	2300
915	914	648	76	230	16.0	150	1900
1065	1067	800	76	230	29.1	220	1600
1220	1219	914	76	230	49.1	273	1400
1370	1372	1067	76	*	80.1	346	1200
1525	1524	1219	76	*	120.5	393	1100
1830	1829	1524	76	*	243.5	522	1000

All dimensions in mm

* Bores cast and machined to order

Hubs

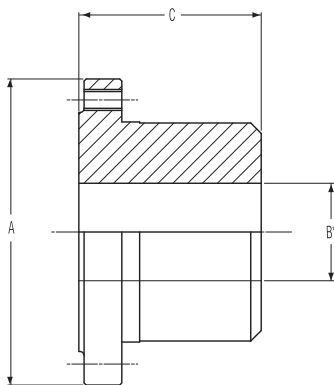

Range of Hubs used with Twiflex Brake Discs

Hub Size	A	B*	C	Disc Size	Max. Brake Torque (kNm)	WR ² (kgm ²)
112	99	14-42	58	250	1.1	0.00097
168	146	28-65	87	300	3.6	0.0088
240	200	60-95	117	400	9.5	0.044
330	272	75-130	155	400	24.0	0.23
370	308	90-150	176	515	30.0	0.35

* Hubs can be supplied with parallel or taper bores, and keywayed to order, at extra cost.

Hubs are manufactured from steel 080M40.

Twiflex offers a wide range of monitoring options for both caliper and modular brake types. This includes a number of IP67-rated inductive and analogue proximity sensors for brake status or pad condition.

In addition, electro-mechanical and limit switches are available as single or multi-function units and may be supplied fully sealed, with positive action safety switches.

Monitoring units are used to indicate:

- Brake on or off, or the fully retracted condition reached
- Adjustment for pad wear required
- Pad replacement needed
- Any combination of the above

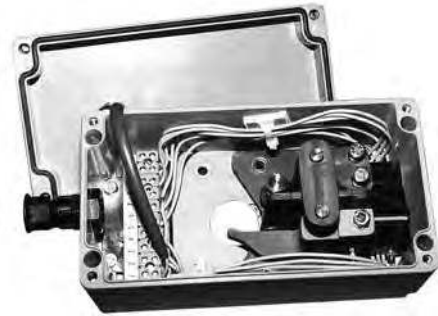

Materials, Traceability & Finishes

Twiflex Ltd. is approved to BS EN ISO 9001:2000, by Lloyds Registry of Quality Assurance. The scope of Twiflex Ltd Quality System embraces all procedures and controls from quotation to delivery of industrial disc brakes.

Materials

All materials are obtained from Twiflex approved suppliers. Twiflex discs and brake housings, unless otherwise stated, are made from Spheroidal Graphite Iron and actuator housings from cast aluminium.

Traceability

We can offer, at customer's request, component traceability through Lloyds. In special circumstances we can also offer traceability through the American Bureau of Shipping (ABS), Det. Norske Veritas (DNV), and other recognized authorities.

Finishes

Twiflex can offer a range of finishing processes, depending upon the degree of protection required. Disc brake assemblies requiring full environmental protection are built using stainless steel, hard chrome plating and marine paint.

Hydraulic Power Units

Twiflex has consolidated decades of development to produce a range of electro-hydraulic power units to meet most application requirements. Each power unit has been designed for reliability, high performance and low maintenance, and is supplied with a comprehensive

easy-to-read installation, operation and maintenance manual. The Twiflex datasheets contain user guides giving a step-by-step selection process. Contact Twiflex application engineers to discuss your requirements in detail.

LC Electro Hydraulic Power Units

The "LC" range of stand alone power units is designed to operate the Twiflex range MR, MX, GMX, GMR and VCS spring applied hydraulically released brakes, providing a basic brake on/off control. There are various options available including "soft braking", a range of operating and motor voltages, and various add-on accessories including a terminal box.

The "soft braking" option is available as an additional manifold slice to facilitate a fast approach, soft braking system. This enables rapid closing of the pad/disc air gap followed by controlled application of braking force up to full torque. Refer to data sheet DS3001.

MP Electro Hydraulic Power Units



The modular "MP" range of electro-hydraulic power packs has been designed to provide a completely flexible means of brake control in the most arduous operating environments.

The units are composed of one of three base modules, dictated by the size and number of calipers to be controlled, comprising motor, pump and reservoir.

The hydraulic circuit is then selected, based on the operation and control logic required by the application and may range from a simple 'on/off' function to full closed loop PLC control. Finally, auxiliary options are specified (for example, hand pump for manual caliper release; heater for low ambient temperatures; stainless steel components for marine environments, etc.).

The "MP" solution is especially useful when the application requires independent control of multiple brake circuits. Refer to data sheet DS3002 or contact Twiflex for more details.

There are many factors to take into account when determining what type of brake to use on any particular machine. For example, what is the function of the brakes? Are there any external loads? Are there any time delays?

The primary consideration should be to answer the question:

“What do you want the brake to do?”

The application will often fall into one of three main types:

- **Holding Brakes**

In such static applications a suitable factor should always be used to compensate for the possibility of foreign matter contaminating the disc surface, loss of conditioning of the brake pad surface, and to provide an appropriate safety margin, depending on pad material, statutory or other requirements.

- **Dynamic and Emergency Brakes**

In a dynamic application the brake must stop all of the moving parts of the machine. Often this function is asked for in conjunction with the holding requirements as an

emergency braking function. Basic calculations should, in these cases, include an assessment of operating temperature, power dissipation (to ensure that the pads are maintained in good condition), and expected pad life.

- **Tension (Continuous Duty) Brakes**

This application arises when the brake is called upon to provide a continuous torque or tension on material passing through the machine, for example on tension reels. Special considerations are required to ensure adequate pad life.

Braking calculations are fundamental to good brake selection. The following calculations are intended only as a guide for those wishing to make their own selection. For a more detailed analysis of a proposed braking system, Twiflex Application Engineers can assist in providing details of all expected operating characteristics using specialist software.

Definition of Braking Terms

Clamping Force (F_n) is the force pressing each brake pad against the disc.

Braking Force (F_b) is the tangential friction force acting between the brake pads and disc.

$$F_b = 2 \cdot \mu \cdot F_n$$

Where: μ is the coefficient of friction between the pad and the disc (a nominal value of 0.4 is assumed for fully conditioned pads of standard material).

Braking Torque (T_b) is the moment of braking force about the center of rotation.

$$T_b = F_b \cdot r_e$$

Where r_e is the effective disc radius.

Calculated braking torques for the range of Twiflex brake calipers are shown in the brochure for a range of standard disc sizes.

Braking Calculations

Definition of Symbols and Units

It is important, when making calculations, that a consistent set of units is used.

Symbols and units

ω_m	Maximum disc speed	[rad/sec]	T_J	Inertia Torque	[Nm]
ω	Deceleration during braking	[rad/sec ²]	T_F	Friction torque	[Nm]
J	Total inertia referred to braked shaft	[kgm ²]	t_b	Braking time	[sec]
m	External load	[kg]	t_d	Delay time for brake signal	[sec]
T_B	Total braking torque	[Nm]	t_s	Overall stopping time	[sec]
T_L	Load torque (out-of-balance torque)	[Nm]	g	Acceleration due to gravity	[m/sec ²]

Basis of Brake Calculation

The fundamentals of braking calculations are to ensure that:

- There is sufficient torque to stop and hold the machine at rest
- For dynamic stops, the power dissipation is acceptable for the area of the brake pads being used
- The operating temperature of the brake disc is controlled, to avoid brake fade and reduced performance

The basic data needed to make an initial calculation are any out-of-balance forces acting on the machine, and the total inertia of the moving parts of the machine.

The total braking torque is defined as follows:

$$T_B = T_J + T_L - T_F$$

Generally the effects of friction can be ignored for a conservative estimate of the required braking torque.

It is important, in all cases of dynamic braking, that the inertia of all of the moving parts is referred to the braked shaft when calculating T_J (see below).

Brake Calculation

Basic braking calculations are derived from simple mechanics. Both the effects of out of balance loads and the torque needed to stop the inertia in the desired way need to be calculated.

Load torque T_L

Where the machine has any out-of-balance load applied the effective out-of-balance torque must be calculated. In the case of a suspended load, for example this is simply given by

$$T_L = m \cdot g \cdot r \text{ [Nm]}$$

where r is the radius at which the load acts (based on drum diameter, reel diameter etc.) The brake will need to overcome this load before it can start to slow down the machine; (it is assumed that the out of balance opposes the action of the brake). If the load is at rest, the static brake torque will prevent the load from moving. In practice a safety factor should be used in the case where the brake is called upon only to hold this load and is only infrequently used in a dynamic manner. In these cases a service factor of 2 is recommended to allow for external environmental conditions, i.e. the brake should be rated to give twice this calculated value.

With some types of machines, such as downhill conveyors or escalators, a component of the load acts in the direction of motion. In these cases the following equation should be used:

$$T_L = m \cdot g \cdot r \cdot \sin \theta \text{ [Nm]}$$

Where θ is the angle of the motion to the horizontal. In cases where the load does not produce a direct torque on the braked shaft (eg. there is a gearbox between the loaded shaft and the brake) the load torque should be calculated accordingly.

In cases of dynamic braking, where the load torque is not constant, for example on wind turbines where the aerodynamic load varies with the speed of the machine, then the equation for T_L becomes complex and it is recommended that selection should be referred to Twiflex.

Inertia torque T_J (dynamic braking only)

Having overcome the external forces additional braking torque is required to stop all the moving parts of the machine. This additional torque is calculated as follows:

$$T_J = J \cdot \dot{\omega} \text{ [Nm]}$$

In this equation the deceleration required can readily be calculated from the braking time.

$$\dot{\omega} = \omega / t_b$$

In some special cases more precise calculation of speed and time may be required.

The moment of inertia of the system (J) should represent all moving parts. For example, in a hoist calculation allowance should be made to include the motor, brake disc, gearbox, winding drum, ropes, load etc. again with a suitable allowance for any mechanical advantage at various parts of the system.

The effective inertia of the load is given simply as:

$$J = m \cdot r^2 \text{ [kgm}^2\text{]}$$

For the winding drum the following well established formula can be used for an initial estimate (can also be used for flat discs):

$$J = \pi \rho l (D^4 - d^4) / 32 \text{ [kgm}^2\text{]}$$

Where l is the length of the drum,

D is the outside diameter

d is the inside diameter and ρ is the density of the material (7840 kg/m³ for steel)

The inertia of the motor should also be included in the calculations. These values can be estimated but should ideally be obtained directly from the manufacturer.

Note: All inertia must be referred to the brake shaft.

For example, if the brake is positioned on the low speed shaft of a machine (gearbox output shaft) then all calculated inertia values (motor, couplings, etc.) must be referred to this shaft.

When referring inertia J_B from one shaft with speed ω_B to another shaft with speed ω_A use:

$$J_A = J_B (\omega_B / \omega_A)^2$$

Special requirements

In certain cases there are other direct considerations to be applied when making braking calculations.

In mine hoists the service factor for holding is defined, as are allowable levels of deceleration, especially when manriding.

For escalators, allowable stopping distances or even rates of deceleration may be defined in local standards.

Twiflex is able to offer assistance with calculations in such special cases.

Braking Calculations

Other Considerations

To optimise braking performance there are other considerations which must be taken into account.

Rubbing speed

For high-speed applications a further consideration is the linear speed at which the disc is passing between the pads when the brake operates. This is important and is usually measured at the effective radius.

Thus the rubbing speed is given as:

$$\text{Rubbing speed} = \omega_m \cdot r_e \text{ (m/s)}$$

In general a maximum speed of 30m/s is recommended for standard brake pad materials. Above this value it is likely that the effective coefficient of friction will be reduced leading to a reduction in braking performance. For certain applications where the rubbing speed is particularly high (up to 100m/s) special pads manufactured from sintered materials are available. Refer to Twiflex for details.

Operating temperatures

During a dynamic application of a brake the energy of the machine will be converted to heat, generated between the pad and the disc. It is the temperature of the disc surface that is normally used to assess the brake performance. Failure to take account of the peak temperature can lead to a reduced braking performance due to the onset of brake fade. With standard brake pads a peak temperature of 250°C has been found to be acceptable, although in certain cases higher temperatures might be permitted. In the case where sintered pads are used peak temperatures in excess of 600°C are possible. The operating temperature also determines pad wear. The higher the temperature, the greater the wear rate of the pads. These calculations require a detailed analysis, carried out by the application engineers at Twiflex, using dedicated software.

Power dissipation

In order to provide a consistent controlled performance of a brake it is also important to check the power dissipated during a stop. This affects the condition of the brake pads.

To calculate the power dissipation it is necessary to calculate the total energy absorbed during the stop, estimated as follows:

$$\text{Kinetic energy (KE)} = J \cdot \omega_m^2 / 2 \text{ (Joules)}$$

In the case of external loads further allowance should also be made for the change in potential energy of the system. For example in the case of a hoist this is determined by how far the load drops during the braking cycle. The mean power dissipated is therefore given by:

$$\text{Mean power dissipation} = \text{KE} / t_b \text{ (Watts)}$$

This is usually converted to what is termed the Mean Specific Power Dissipation (kW/cm²) for evaluation of pad performance, i.e. the mean power dissipation is divided by the pad area.

A value of 0.7kW/cm² has been shown to be acceptable for emergency stops of around 10 seconds duration, providing that the pads have been well bedded in and conditioned. Higher values can be used for shorter stopping times.

For tensioning duties the value of the mean specific power dissipation is more typically around 0.06 kW/cm². Failure to observe this basic selection criteria may result in poor braking performance and limited pad life.

Twiflex application engineers will be only too happy to assist in the selection process to meet your application requirements.

Application Data Form

Mail or Fax to:

Twiflex Limited
Technical Sales Department
9 Briar Road, Twickenham,
Middlesex. TW2 6RB England

Date _____
Company _____
Address _____
City _____ County _____ Postcode _____

FAX: +44 (0) 20 8755 5601
Phone: +44 (0) 20 8894 1161

Name _____
Title _____ Phone (_____) _____
Email _____ FAX (_____) _____

- Urgent For Review Please Comment Please Reply Please Recycle

Application Description

Type of braking required: (eg: Holding, Dynamic Stopping, Emergency Stopping, Tensioning):

Service Brake: (Between motor and gearbox): _____

Motor Rating: _____

Safety Braking Required? _____

Brake Torque: _____

Comments

Drawing of Application

All Customer Service phone numbers shown in bold

<p>Electromagnetic Clutches and Brakes</p> <p>Warner Electric <i>Electromagnetic Clutches and Brakes</i> New Hartford, CT - USA 1-800-825-6544 <i>For application assistance: 1-800-825-9050</i></p> <p>St Barthelemy d'Anjou, France +33 (0) 2 41 21 24 24</p> <p><i>Precision Electric Coils and Electromagnetic Clutches and Brakes</i> Columbia City, IN - USA 1-260-244-6183</p> <p>Matrix International <i>Electromagnetic Clutches and Brakes, Pressure Operated Clutches and Brakes</i> Brechin, Scotland +44 (0) 1356 602000 New Hartford, CT - USA 1-800-825-6544</p> <p>Inertia Dynamics <i>Spring Set Brakes; Power On and Wrap Spring Clutch/Brakes</i> New Hartford, CT - USA 1-800-800-6445</p>	<p>Couplings</p> <p>Ameridrives Couplings <i>Mill Spindles, Ameriflex, Ameridisc</i> Erie, PA - USA 1-814-480-5000</p> <p><i>Gear Couplings</i> San Marcos, TX - USA 1-800-458-0887</p> <p>Bibby Turboflex <i>Disc, Gear, Grid Couplings, Overload Clutches</i> Dewsbury, England +44 (0) 1924 460801 Boksburg, South Africa +27 11 918 4270</p> <p>TB Wood's <i>Elastomeric Couplings</i> Chambersburg, PA - USA 1-888-829-6637 – Press #5 <i>For application assistance: 1-888-829-6637 – Press #7</i></p> <p><i>General Purpose Disc Couplings</i> San Marcos, TX - USA 1-888-449-9439</p> <p>Ameridrives Power Transmission <i>Universal Joints, Drive Shafts, Mill Gear Couplings</i> Green Bay, WI - USA 1-920-593-2444</p> <p>Huco Dynatork <i>Precision Couplings and Air Motors</i> Hertford, England +44 (0) 1992 501900 Chambersburg, PA - USA 1-800-829-6637</p> <p>Lamiflex Couplings <i>Flexible Couplings, Bearing Isolators, and Coupling Guards</i> São Paulo, SP - Brasil (11) 5679-6533</p>	<p>Heavy Duty Clutches and Brakes</p> <p>Wichita Clutch <i>Pneumatic Clutches and Brakes</i> Wichita Falls, TX - USA 1-800-964-3262 Bedford, England +44 (0) 1234 350311</p> <p>Twiflex Limited <i>Caliper Brakes and Thrusters</i> Twickenham, England +44 (0) 20 8894 1161</p> <p>Industrial Clutch <i>Pneumatic and Oil Immersed Clutches and Brakes</i> Waukesha, WI - USA 1-262-547-3357</p> <p>Gearing</p> <p>Boston Gear <i>Enclosed and Open Gearing, Electrical and Mechanical P.T. Components</i> Charlotte, NC - USA 1-800-825-6544 <i>For application assistance: 1-800-816-5608</i></p> <p>Bauer Gear Motor <i>Gearred Motors</i> Esslingen, Germany +49 (711) 3518 0 Somerset, NJ - USA 1-732-469-8770</p> <p>Nuttall Gear and Delroyd Worm Gear <i>Worm Gear and Helical Speed Reducers</i> Niagara Falls, NY - USA 1-716-298-4100</p>	<p>Overrunning Clutches</p> <p>Formsprag Clutch <i>Overrunning Clutches and Holdbacks</i> Warren, MI - USA 1-800-348-0881 – Press #1 <i>For application assistance: 1-800-348-0881 – Press #2</i></p> <p>Marland Clutch <i>Roller Ramp and Sprag Type Overrunning Clutches and Backstops</i> South Beloit, IL - USA 1-800-216-3515</p> <p>Stieber Clutch <i>Overrunning Clutches and Holdbacks</i> Heidelberg, Germany +49 (0) 6221 30 47 0</p> <p>Belted Drives and Sheaves</p> <p>TB Wood's <i>Belted Drives</i> Chambersburg, PA - USA 1-888-829-6637 – Press #5 <i>For application assistance: 1-888-829-6637 – Press #7</i></p> <p>Engineered Bearing Assemblies</p> <p>Kilian Manufacturing <i>Engineered Bearing Assemblies</i> Syracuse, NY - USA 1-315-432-0700</p> <p><small>For information concerning our sales offices in Asia Pacific check our website www.altramotion.com.cn</small></p>
<p>Linear Products</p> <p>Warner Linear <i>Linear Actuators</i> Belvidere, IL - USA 1-800-825-6544 <i>For application assistance: 1-800-825-9050</i></p> <p>St Barthelemy d'Anjou, France +33 (0) 2 41 21 24 24</p>			



www.twiflex.com

9 Briar Road, Twickenham
Middlesex, England TW2 6RB
+44 (0) 208 894 1161
Fax: +44 (0) 20 8755 5601