

MU Disc Brake Caliper

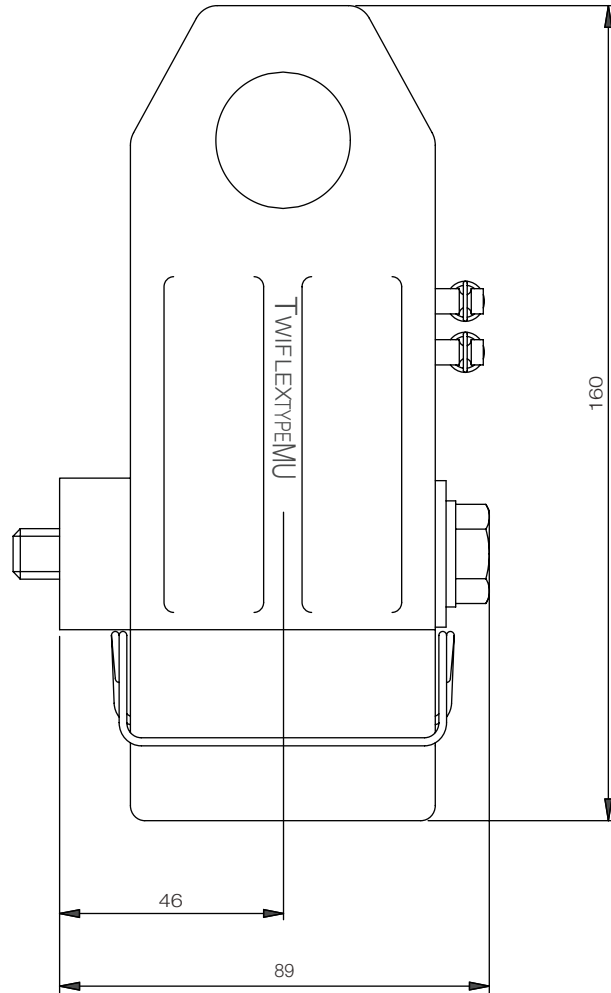

Caliper Part Number. 7680918

- Weight 0.75 kg.
- Pad wear allowance 5mm
- Total pad area 58cm (2 Pads)
- Pad dimensions new 30x50x21 thk.
- Pad material Asbestos-free high friction material

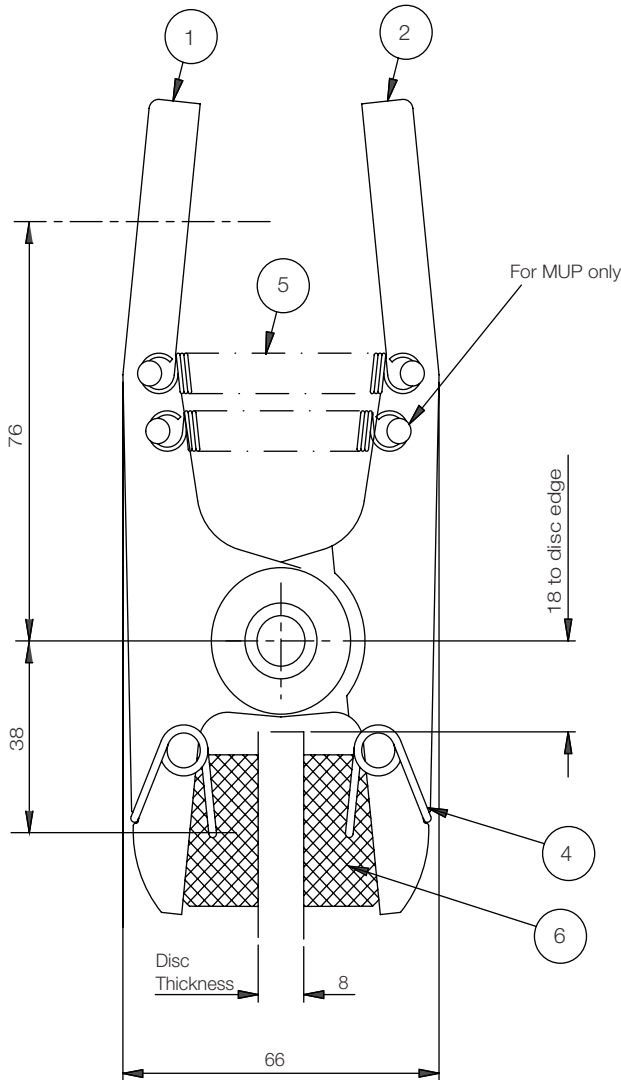
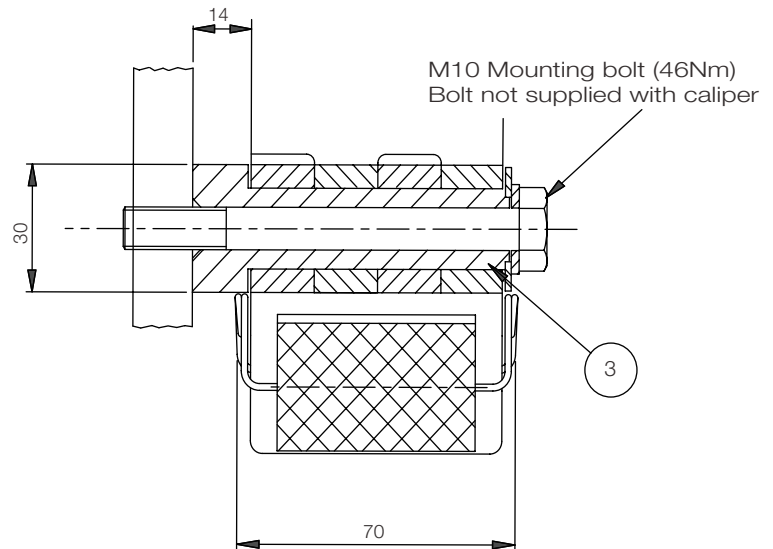

AVAILABLE SPARES

Item	Component	Part No.
1	Arm Assembly - Thruster	6640177
2	Arm Assembly - Slotted	640178
3	Pivot Post	8240039
4	Pad Retaining Spring	2400093
5	Tension Spring	2400109
6	Brake Pad	7080047

MU Disc Brake Caliper

General Description

The 'MU' series of disc brake calipers are the smallest in the Twiflex range and are designed for light duty stopping and holding applications.

This range of brake calipers can be used with 8mm or 12.7mm thick discs.

Normally one or two units will be used per disc but the number may be increased, depending on disc size.

The brake units can be positioned at any angle around the periphery of the disc, but ideally they should be mounted horizontally (in 3 or 9 o'clock positions) in relation to the disc.

Brake	Description	Data Sheet	Maximum Braking Force - kN
MU3	Pneumatically applied - Spring released	1001	2.75
MUP	Pneumatically applied - Spring released	1002	0.72
MUS2	Spring applied - pneumatically released	1003	0.6
MUS3	Spring applied - pneumatically released	1004	0.76
MUS4	Spring applied - pneumatically released	1005	2.6
MUH	Mechanically applied - Hand operated	1006	0.51

Disc:

A range of standard discs of 12.7mm thick are available from Twiflex see Data Sheet DS0501.
Minimum disc diameter for the MU caliper is 150mm

Controllers:

Standard Twiflex Controllers are available for single or multi-caliper installations for use with electric, pneumatic and hydraulic signalling systems.

Pad replacement in air applied calipers:

To replace the pads, secure the installation to ensure safety.

With the aid of a pair of pliers, pull the pad retaining spring from one end of the pad, detach the spring completely from the pad and remove the pad from the arm. Remove the second pad from the other arm.

Clean the disc and pad recesses in the arms with a suitable cleaning agent such as white spirit.

Place a new pad into the recess in one arm, engage one end of the pad retaining spring to the pad, and ease the spring apart with pliers and fit the spring, ensuring that the spring also locates into the slot in the arm. Fit the second pad to the other arm. Manually rotate the pads in the arm recesses so the pad friction faces are parallel to the disc surface at the point of engagement.

Pad replacement in spring applied calipers:

To replace the pads, secure the installation to ensure safety.

Slacken the two locknuts holding the thruster, and screw back the push rod to create space between pad and disc.

With the aid of a pair of pliers, pull the pad retaining spring from one end of the pad, detach the spring completely from the pad and remove the pad from the arm. Remove the second pad from the other arm.

Clean the disc and pad recesses in the arms with a suitable cleaning agent such as white spirit.

Place a new pad into the recess in one arm, engage one end of the pad retaining spring to the pad, and ease the spring apart with pliers and fit the spring, ensuring that the spring also locates into the slot in the arm. Fit the second pad to the other arm. Refit the thruster as described in the relevant data sheet. Manually rotate the pads in the arm recesses so the pad friction faces are parallel to the disc surface at the point of engagement.

For bedding-in and conditioning procedures see publication M1060
Health and Safety data sheet refer to DS 050