



**Heavy Duty
Gen2
UniModule
for
Tough
Conveyor
Applications**



 **Warner[®]**
Electric

An Altra Industrial Motion Company



Two significant design modifications make the Heavy Duty Gen2 UniModule ideal for use in tough conveyor applications including baggage handling systems

Heavy Duty



Standard

Modified Armature and Spline Hub

The effective spline length increased by 83% resulting in a 44% decrease in spline compressive stress.

Cycling conveyor test in laboratory environment

- HD Module had zero spline wear in 300,000 cycles



Heavy Duty Standard

Higher Load Capacity Bearing

Bearing dynamic load capability* increased by 47%.

*Calculated using 250 lbs. total belt load at 2 inches from module face.

Choose from two Heavy Duty models

Fully assembled, pre-burnished and factory tested

For 143/145TC NEMA Frame, up to 2 hp:

UM-180-1020, 90 vdc Part #5370-273-323

UM-180-1020, w/CBC-150 Part #5370-273-324



Optional Field Installable Cover Kit is available to create a fully enclosed unit.

Part #5370-101-076



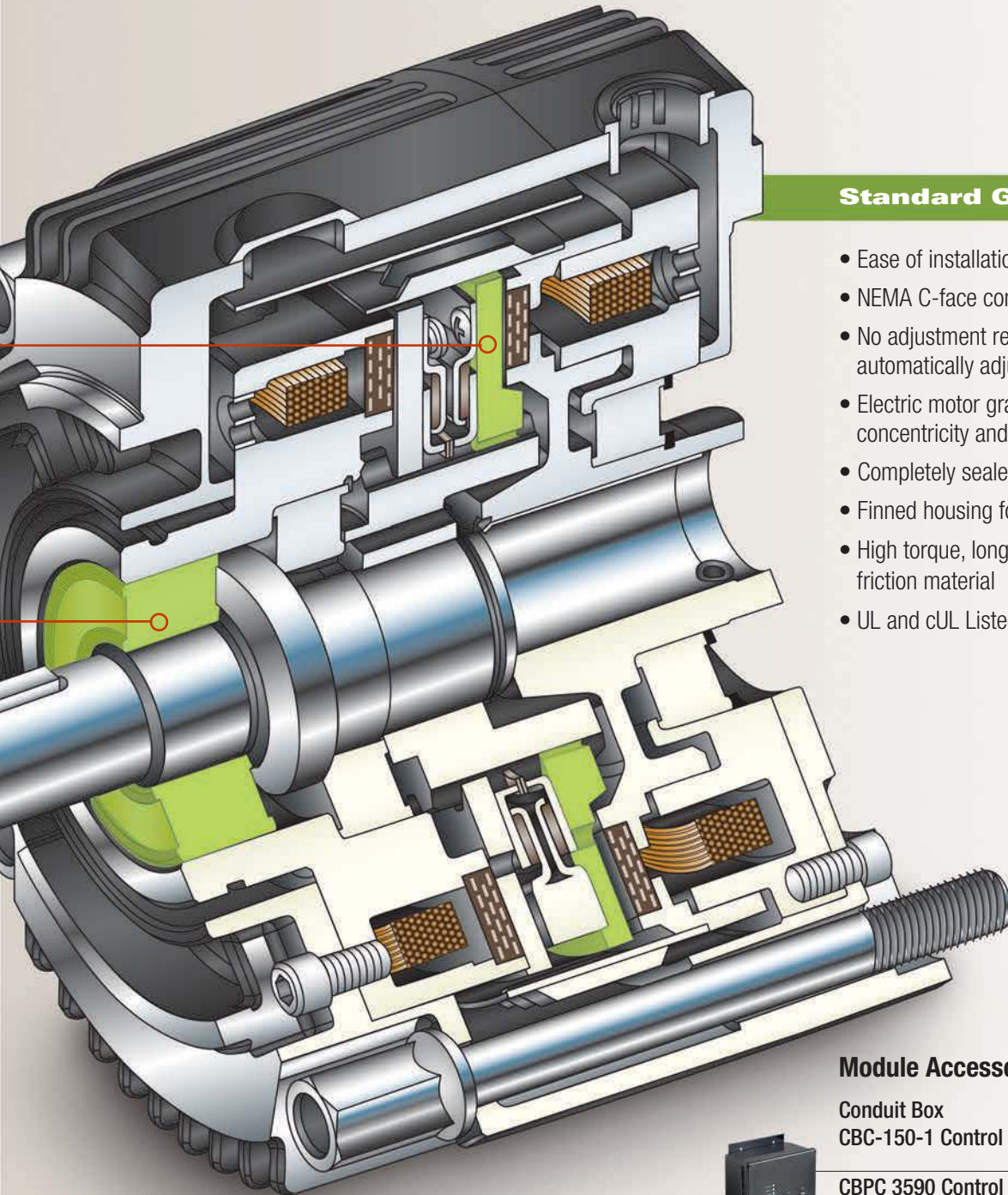

Standard Gen2 Features

- Ease of installation – bolt it down, wire it up
- NEMA C-face compatible mounting
- No adjustment required – patented Autogaps™ automatically adjust for wear
- Electric motor grade bearings maintain tight concentricity and running efficiency
- Completely sealed coils
- Finned housing for maximum heat dissipation
- High torque, long life, lead-free, and asbestos-free friction material
- UL and cUL Listed

Module Accessories

Conduit Box Part #5370-101-042
 CBC-150-1 Control Part #6004-448-001

CBPC 3590 Control Part #6051-448-002

Clutch Brake Positioning Control is designed for airport baggage handling diverters. This dedicated control incorporates a counter system, control logic, and clutch/brake power supply for closed loop control operation. The CBC-3590 is a direct replacement of the CBC-1500 AFHC.



Electromagnetic Clutches and Brakes

Warner Electric

Electromagnetic Clutches and Brakes

New Hartford, CT - USA
1-800-825-6544

For application assistance:
1-800-825-9050

St Barthelemy d'Anjou, France
+33 (0) 2 41 21 24 24

Precision Electric Coils and Electromagnetic Clutches and Brakes

Columbia City, IN - USA
1-260-244-6183

Matrix International

Electromagnetic Clutches and Brakes, Pressure Operated Clutches and Brakes

Brechin, Scotland
+44 (0) 1356 602000

New Hartford, CT - USA
1-800-825-6544

Inertia Dynamics

Spring Set Brakes; Power On and Wrap Spring Clutch/Brakes

New Hartford, CT - USA
1-800-800-6445

Linear Products

Warner Linear

Linear Actuators
Belvidere, IL - USA
1-800-825-6544

For application assistance:
1-800-825-9050

St Barthelemy d'Anjou, France
+33 (0) 2 41 21 24 24

Couplings

Ameridrives Couplings

Mill Spindles, Ameriflex, Ameridisc

Erie, PA - USA
1-814-480-5000

Gear Couplings

San Marcos, TX - USA
1-800-458-0887

Bibby Transmissions

Disc, Gear, Grid Couplings, Overload Clutches

Dewsbury, England
+44 (0) 1924 460801

Boksburg, South Africa
+27 11 918 4270

TB Wood's

Elastomeric Couplings

Chambersburg, PA - USA
1-888-829-6637 – Press #5

For application assistance:
1-888-829-6637 – Press #7

General Purpose Disc Couplings

San Marcos, TX - USA
1-888-449-9439

Ameridrives Power Transmission

Universal Joints, Drive Shafts, Mill Gear Couplings

Green Bay, WI - USA
1-920-593-2444

Huco Dynatork

Precision Couplings and Air Motors

Hertford, England
+44 (0) 1992 501900

Charlotte, NC - USA
1-800-825-6544

Heavy Duty Clutches and Brakes

Wichita Clutch

Pneumatic Clutches and Brakes

Wichita Falls, TX - USA
1-800-964-3262

Bedford, England
+44 (0) 1234 350311

Twiflex Limited

Caliper Brakes and Thrusters

Twickenham, England
+44 (0) 20 8894 1161

Industrial Clutch

Pneumatic and Oil Immersed Clutches and Brakes

Waukesha, WI - USA
1-262-547-3357

Gearing

Boston Gear

Enclosed and Open Gearing, Electrical and Mechanical P.T. Components

Charlotte, NC - USA
1-800-825-6544

For application assistance:
1-800-816-5608

Bauer Gear Motor

Geared Motors

Esslingen, Germany
+49 (711) 3518-0

Nuttall Gear and Delroyd Worm Gear

Worm Gear and Helical Speed Reducers

Niagara Falls, NY - USA
1-716-298-4100

Overrunning Clutches

Formsprag Clutch

Overrunning Clutches and Holdbacks

Warren, MI - USA
1-800-348-0881 – Press #1

For application assistance:
1-800-348-0881 – Press #2

Marland Clutch

Roller Ramp and Sprag Type Overrunning Clutches and Backstops

South Beloit, IL - USA
1-800-216-3515

Stieber Clutch

Overrunning Clutches and Holdbacks

Heidelberg, Germany
+49 (0) 6221 30 47 0

Belted Drives and Sheaves

TB Wood's

Belted Drives

Chambersburg, PA - USA
1-888-829-6637 – Press #5

For application assistance:
1-888-829-6637 – Press #7

Engineered Bearing Assemblies

Kilian Manufacturing

Engineered Bearing Assemblies

Syracuse, NY - USA
1-315-432-0700

For information concerning our sales offices in Asia Pacific check our website
www.altramotion.com.cn



An Altra Industrial Motion Company

www.warnerelectric.com

31 Industrial Park Road
New Hartford, CT 06057 - USA
815-389-3771
Fax: 815-389-2582

7, rue Champfleu, B.P. 20095
St Barthelemy d'Anjou, France
+33 (0)2 41 21 24 24
Fax: **+33 (0)2 41 21 24 70**