

Airflex® Air Cooled Disc Clutches and Brakes

Section E

DBA Description	181
DBA Brake Elements	183
DBA Technical information	184
DBB and DBBS Description	185
DBB Brake Elements	187
DBB Technical Information	188
DBBS Brake Elements	189
DBBS Technical Information	191
Type DC Description	192
DC Technical and Dimensional Data	194
Type FHB Description	196
Floating Housing Brake Technical and Dimensional Data.....	197
Selection Procedure	200

Airflex® DBA Description

Section E

Model DBA brakes are spring applied, pressure released, disc style brakes. They develop equal torque in either direction of rotation. Their torque and thermal capacities allow them to be used in the most demanding applications.

Brake construction and operation is shown in the figure. Pressurizing the brake compresses the brake springs and withdraws the clamping plates from the brake discs. Standard brakes are furnished with either one or two discs, which are free to move axially.

Model DBA uses a rubber diaphragm to form the releasing pressure chamber and to serve as the releasing piston. Brake friction material is attached to stationary components. Brake discs are either solid or ventilated. The disc type is indicated by an S for solid, or V, for ventilated, in the brake model designation. Solid discs are used in applications requiring a heat sink and/or where engagement is infrequent. Ventilated discs are recommended for cyclic applications.

Torque ratings listed are for brakes with a standard complement of springs. The quantity of springs can be varied to customize the torque of the brake to suit a particular application. Consult the factory for brake torque of units with non-standard spring configurations.

Brake sizes are indicated by the number of brake discs and the disc diameter in inches. For instance, size 229DBA has two discs 29 inches in diameter.

Features

Large friction area.

Allows brakes to absorb and dissipate high energy loads associated with high cyclic and high inertia stops.

Minimal adjustment required for lining wear.

Single disc units require no wear adjustment and dual disc units require only one wear adjustment during the long life of the friction material.



Where used:

- Can making machines
- Draglines
- Power shovels
- Conveyors
- Power presses

Airflex® DBA Component parts

Section E

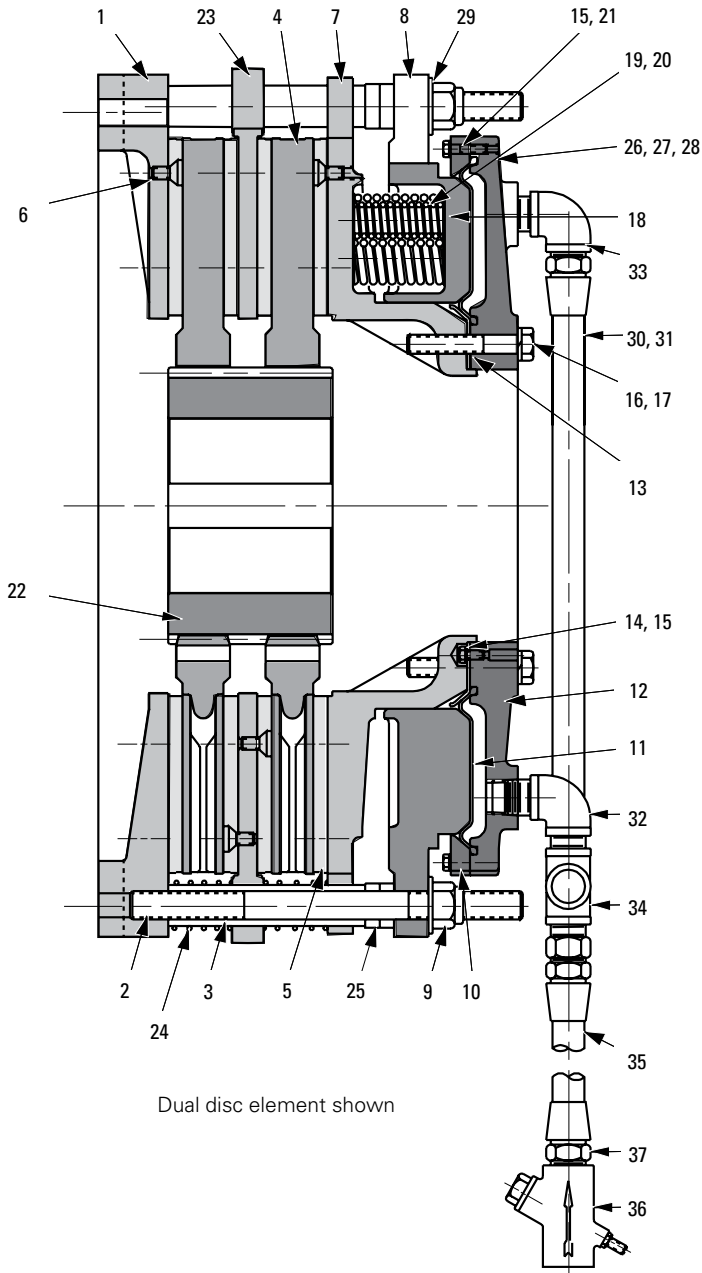

Item Number	Description
1	Mounting Flange
2	Stud
3	Clamp Tube
4	Disc
5	Friction Disc
6	Flat Head Screw
7	Pressure Plate
8	Spring Housing
9	Locknut
10	Outer Clamp Ring
11	Diaphragm
12	End Plate
13	Inner Clamp Ring
14	Hex Head Screw
15	Lockwasher
16	Hex Head Screw
17	Lockwasher
18	Spring Retainer Plate
19	Inner Spring
20	Outer Spring
21	Hex Head Screw
22	Gear
23	Reaction Plate
24	Release Spring
25	Wear Spacer
26	Name Plate
27	Self Tapping Screw
28	Warning Decal
29	Washer
30	Air Tube
31	Air Tube
32	90 Deg. Street Elbow
33	90 Deg. Male Elbow
34	Cross
35	Hose Assembly
36	Flow Control Valve
37	Bushing

Airflex® DBA Brake Elements

Form DBA808 — Dimensional and Technical Data

Section E

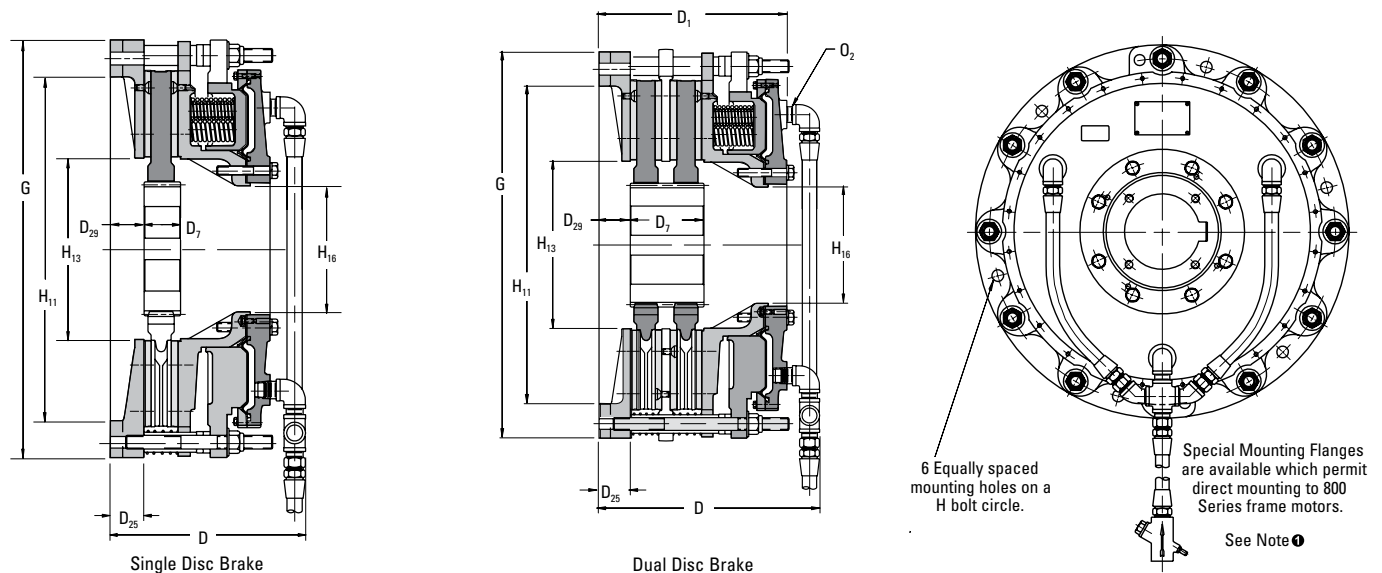

English	Dimensions in inches								
17DBA	2.00	21.000	17.25	10.00	5.38	24.998	0.78	1/2-14	
21DBA	2.00 2	3.000	21.00	12.12	7.62	26.498	1.06	1-11 1/2	
29DBA	2.75	31.000	28.00	14.75	10.25	33.998	1.06	1-11 1/2	
Basic Size	D ₂₅	H	H ₁₁	H ₁₃	H ₁₆	G e	L	O ₂ e	
17DBA	51	533	438	254	137	634,9	20	1/2-14	
21DBA	51	584	533	308	194	673,0	27	1-11 1/2	
29DBA	70	787	711	375	260	863,5	27	1-11 1/2	
SI	Dimensions in millimeters								

English	Dimensions in inches								
117DBA	2.50	4.25	12.55	11.19	4.88	1.00	10.69	4.88	1.88
217DBA	3.25	4.25	15.77	14.41	6.50	1.88	13.41	6.50	1.88
121DBA	2.88	5.75	13.19	11.33	2.50	2.12	11.33	5.62	2.00
221DBA	3.88	5.88	16.47	14.61	5.63	2.12	14.23	5.62	2.25
129DBA	3.94	7.38	15.51	13.75	3.50	2.25	15.06	5.88	2.38
229DBA	4.88	7.19	19.13	17.38	7.12	2.25	18.06	7.00	3.12
329DBA	5.63	6.88	22.93		10.63	2.34			

Size	Bore Range		Ventilated Disc Types				Solid Disc Types		
	Min.	Max.	D	D ₁	D ₇	D ₂₉	D	D ₇	D ₂₉
117DBA	64	108	319	284	124	25	272	124	48
217DBA	79	108	401	366	165	48	341	165	48
121DBA	73	146	335	287	64	54	288	143	51
221DBA	98	149	418	371	143	54	361	143	57
129DBA	105	187	394	349	89	57	383	149	60
229DBA	124	182	486	441	181	59	459	178	79
329DBA	143	175	582		270	59			
SI	Dimensions in millimeters								

Notes:

① All ventilated disc brakes are furnished with an approximate 15.5 inch (394 mm) length of flexible hose and a flow control valve having a 1-11 1/2 American National Pipe Thread port.

② Tolerance +0.000/-0.003 in (+0,00/-0,08 mm)

③ American National Pipe Thread

Airflex® DBA Elements

Dimensional and Technical Data

Section E

English			lb-in	psi	in ³	in ²	lb-ft ²	lb			rpm
117DBAS	146148	413113	29300	85	100	270	18	95	410		2300
217DBAS	146152	413248	52600	85	100	540	35	160	455		2300
121DBAS	146145	413534	69800	85	160	406	42	130	610		1900
221DBAS	146151	413535	129300	85	160	812	80	270	565		1900
129DBAS	146162	413801	176700	100	310	890	152	325	950		1500
229DBAS	146163	414126	336200	100	310	1780	292	520	1150		1500

Size	① Part Number	Gear Part Number	M ₂₀₀ Torque Rating	Minimum Releasing Pressure	⑤ Releasing Volume	Friction Area	Disc & Gear	Disc & Gear	Housing	Maximum Speed	
							Wk ² J	Weight Mass			
117DBAS	146148	413113	3310	5,9	1,64	1742	0,76	43	186	2300	
217DBAS	146152	413248	5940	5,9	1,64	3483	1,47	72	206	2300	
121DBAS	146145	413534	7890	5,9	2,62	2619	1,76	59	276	1900	
221DBAS	146151	413536	14600	5,9	2,62	5237	3,36	122	256	1900	
129DBAS	146162	413801	20000	6,9	5,08	5741	6,38	147	430	1500	
229DBAS	146163	414126	38000	6,9	5,08	11481	12,26	236	521	1500	
SI			N·m	bar	dm³	cm²	kg·m²	kg			rpm

English			lb-in	in ³	in ²	lb-ft ²	lb			rpm
117DBAV	146148	413113	20500	100	270	10	70	320		1300
217DBAV	146152	413248	38000	100	540	20	112	363		1300
121DBAV	146145	413534	52500	160	406	30	105	480		1000
221DBAV	146151	413535	96000	160	812	60	210	565		1000
129DBAV	146162	413683	113000	310	890	97	185	970		900
229DBAV	146163	413585	216000	310	1780	191	340	1150		900
329DBAV	146210	415080	339000	310	2670	285	495	1549		900

Size	① Part Number	Gear Part Number	M ₂₀₀ Torque Rating	⑤ Releasing Volume	Friction Area	Disc & Gear	Disc & Gear	Housing	Maximum Speed	
							Wk ² J	Weight Mass		
117DBAV	146148	413113	2320	1,64	1742	0,42	32	145	1300	
217DBAV	146152	413248	4290	1,64	3483	0,84	51	164	1300	
121DBAV	146145	413534	5930	2,62	2619	1,26	48	217	1000	
221DBAV	146151	413535	10800	2,62	5237	2,52	95	256	1000	
129DBAV	146162	413683	12800	5,08	5741	4,07	84	439	900	
229DBAV	146163	413585	24400	5,08	11481	8,02	154	521	900	
329DBAV	146210	415080	38400	5,08	17223	11,97	224	708	900	
SI			N·m	dm³	cm²	kg·m²	kg			rpm

Notes:

- ① Basic part number only. Does not include gear. Gear must be ordered separately with the bore and keyway requirements.
- ② Dynamic torque shown. Static torque approximately 1.15 greater. Torque values are for new linings. Torque decreases with lining wear. At the worn out condition, torque is approximately 0.66 of values shown.
- ③ Torque ratings are for units with a standard complement of springs. Consult factory for torque ratings of units with non-standard spring configurations.
- ④ Maximum allowable cylinder pressure is 120 psi (8,3 bar).
- ⑤ Absolute volume of releasing cavity.
- ⑥ Minimum releasing pressure 60 psi (4,1 bar).

Airflex® DBB Description

Section E

Model DBB brakes are spring applied, pressure released, disc style brakes. They develop equal torque in either direction of rotation. Their torque and thermal capacities allow them to be used in the most demanding applications.

Brake construction and operation is shown in the figure. Pressurizing the brake compresses the brake springs and withdraws the clamping plates from the brake discs. Standard brakes are furnished with either one or two discs, which are free to move axially.

Model DBB uses a conventional piston design to release the brake discs. The rotating component of the DBB style brake is a very low inertia friction disc core with riveted on friction discs. The low inertia of the rotating components coupled with the high heat sink capacity of the stationary members allow these units to provide superior performance in high cyclic applications. In applications requiring higher speed operation or where precise balance of the rotating components is required, the DBBS style is offered, which utilizes a solid rotor and stationary friction material. Similar to the DBAS design, the DBBS should only be used for applications where brake engagement is non-cyclic.

Torque ratings listed are for brakes with a standard complement of springs. The quantity of springs can be varied to customize the torque of the brake to suit a particular application. Consult the factory for brake torque of units with non-standard spring configurations.

Brake sizes are indicated by the number of brake discs and the disc diameter in inches. For instance, size 225DBB has two discs 25 inches in diameter.

Features

Low inertia friction disc assembly.

Reduces the overall inertia that must be stopped.

Optional split friction discs.

Allows removal of friction discs without disturbing other components of drive system in mid-shaft brake arrangement.

Long wearing, self lubricating PolyPak* seals.

Eliminates premature twisting failure and requires no external lubrication.



Where used:

- Bottling equipment
- Power Shovels
- Conveyors
- Shears
- Power Presses

Airflex® DBB Description

Section E

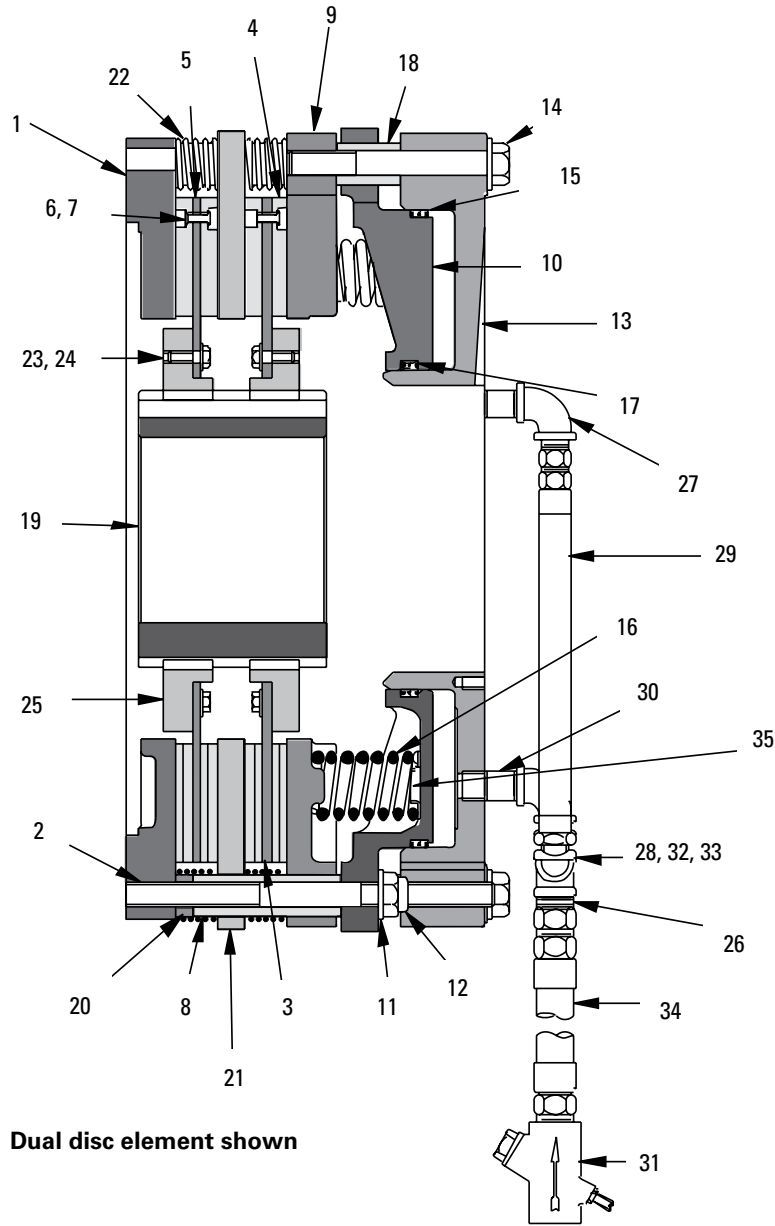

Item Number	Description
1	Mounting Flange
2	Stud
3	Friction Disc Sub-Assembly
4	Friction Disc
5	Friction Disc Core
6	Rivet
7	Washer
8	Clamp Tube
9	Pressure Plate
10	Spring Housing
11	Flat Washer
12	Locknut

Item Number	Description
13	Cylinder
14	Hex Head Screw
15	Outer Seal
16	Spring
17	Inner Seal
18	Spacer Tube
19	Gear
20	Wear Spacer
21	Reaction Plate
22	Release Spring
23	Flat Washer
24	Hex Head Screw

Item Number	Description
25	Ring Gear
26	Pipe Nipple
27	Elbow
28	Pipe Cross
29	Hose Assembly
30	Pipe Nipple
31	Flow Control Valve
32	45 Deg. Street Elbow
33	Pipe Reducer
34	Hose Assembly
35	Spring Retainer

Airflex® DBB Brake Elements

Dimensional and Technical Data Section E

English	Dimensions in inches				
109DBB	1.68	2.50	7.26	1.75	6.06
209DBB	1.94	2.56	8.70	4.00	7.53
309DBB	2.13	2.63	9.06	5.25	9.06
115DBB	2.13	2.50	4.38	2.88	7.52
215DBB	3.06	4.25	11.16	4.38	9.23
120DBB	3.00	5.88	10.87	3.00	9.37
220DBB	3.75	6.00	13.04	6.27	11.54
320DBB	4.25	5.88	15.21	8.25	13.68
420DBB	4.50	5.88	17.38	10.31	15.84
125DBB	3.88	7.50	12.07	3.50	10.57
225DBB	3.88	7.56	14.38	7.00	12.88
325DBB	5.38	7.50	16.69	9.31	15.19
425DBB	5.88	7.50	19.00	12.00	17.50
138DBB	6.00	11.00	16.25	5.00	14.25
238DBB	7.38	11.00	19.05	9.00	17.05
338DBB	8.38	10.88	21.85	12.00	19.73
438DBB	9.06	10.88	24.65	5.00	22.52
Size ♦	Bore Range		D Ⓞ	D1	W4 Ⓞ
	Min.	Max.			

SI	Dimensions in millimeters				
109DBB	43	64	184	44	154
209DBB	49	65	221	102	191
309DBB	54	67	202	133	230
115DBB	54	64	242	73	191
215DBB	78	108	283	111	235
120DBB	76	149	276	76	238
220DBB	95	152	331	159	292
320DBB	108	149	386	210	347
420DBB	114	149	441	262	402
125DBB	99	191	307	89	268
225DBB	99	192	365	178	327
325DBB	137	191	424	236	386
425DBB	149	191	483	305	445
138DBB	152	279	413	127	362
238DBB	187	279	484	229	433
338DBB	213	276	555	305	501
438DBB	230	276	626	381	572
Size ♦	Bore Range		D Ⓞ	D1	W4 Ⓞ
	Min.	Max.			

English	Dimensions in inches								
9DBB	1.00	0.25	①	3.12	12.125 ②	8.375	12.37	3/8-18	
15DBB	1.47	0.38	0.38	6.00	18.375 ②	14.375	18.94	1/2-14	
20DBB	1.50	0.38	1.00	8.50	23.250 ⑦	18.250	23.82	1/2-14	
25DBB	1.75	0.25	0.75	11.50	30.630 ⑦	24.375	30.89	1/2-14	
38DBB	2.45	0.25	1.25	16.50	44.750 ⑦	36.375	45.01	3/4-14	
Size	D ₃₁	D ₄₄	D ₄₅	H ₁₆	J	J ₁ Ⓞ	J ₂ ▼	O ₂ Ⓞ	
9DBB	25	6	①	79	308.0	212.7	314	3/8-18	
15DBB	37	10	10	152	466.7	365.1	481	1/2-14	
20DBB	38	10	25	216	590.6	463.5	605	1/2-14	
25DBB	44	6	19	292	778.0	619.1	785	1/2-14	
38DBB	62	6	32	419	1136.7	923.9	1143	3/4-14	

SI	Dimensions in millimeters							
9DBB	25	6	①	79	308.0	212.7	314	3/8-18
15DBB	37	10	10	152	466.7	365.1	481	1/2-14
20DBB	38	10	25	216	590.6	463.5	605	1/2-14
25DBB	44	6	19	292	778.0	619.1	785	1/2-14
38DBB	62	6	32	419	1136.7	923.9	1143	3/4-14

Mounting Bolt Circles

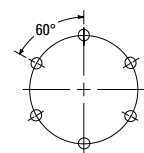

9DBB
(6) 0.531 (13.5) Ø Mounting holes equally spaced as shown on 11.125 (282.5) Bolt

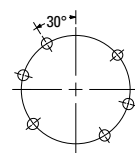

15DBB
(6) 0.656 (16.7) Ø Mounting holes based on 8 equally spaced holes on

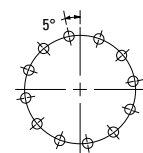

20DBB
(12) 0.656 (16.7) Ø Mounting holes equally spaced as shown on 22.000 (558.8) Bolt

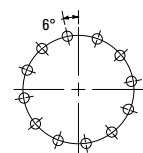

* 25DBB
(12) 0.656 (16.7) Ø Mounting holes equally spaced as shown on 28.750 (730.3) Bolt Circle

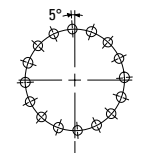

38DBB
(16) 1.062 (27.0) Ø Mounting holes equally spaced as shown on 42.000 (1066.8)

* Sizes 325 & 425 have 0.781" (19.8 mm) Mounting Hole

Notes:

- ① 0.50 in (13mm) for 109 DB
0.25 in (6mm) for 209 DBB
0.00 in (0mm) for 309 DBB
- ② Tolerance +0.000/-0.003 in (+0,00/-0,08 mm)
- ③ Tolerance +0.003/-0.000 in (+0,08/-0,00 mm)
- ④ American National Pipe Thread.
- ⑤ Brake in disengaged position.
- ⑥ All DBB brakes can be supplied plumbed as shown with a flow control valve having American National Pipe thread ports of 1/2-14 for size 9DBB, 3/4-14 for sizes 15DBB, 20 DBB, 25DBB and 1-11 1/2 for size 38DBB
- ⑦ Tolerance +/- 0.12
- ⑧ Basic part number only. Does not include gear. Gear must be ordered separately with the bore and keyway requirements.
- ⑨ Dynamic torque shown. Static torque approximately 15% greater. Torque values are for new linings. Torque decreases with lining wear. At the worn out condition, torque is approximately 0.66 of values shown.
- ⑩ Torque ratings are for units with a standard complement of springs. Consult factory for torque ratings of units with non-standard spring configurations.
- ⑪ Maximum allowable cylinder pressure is 120 psi (8,3 bar).
- ▲ Absolute volume of releasing cavity.
- ▼ Maximum diameter of "as cast" surfaces.
- ◆ Some high torque applications of three and four disc elements require additional support on the cylinder side of the unit. Contact your local Airflex representative for more details.

Airflex® DBB Brake Elements

Dimensional and Technical Data

Section E

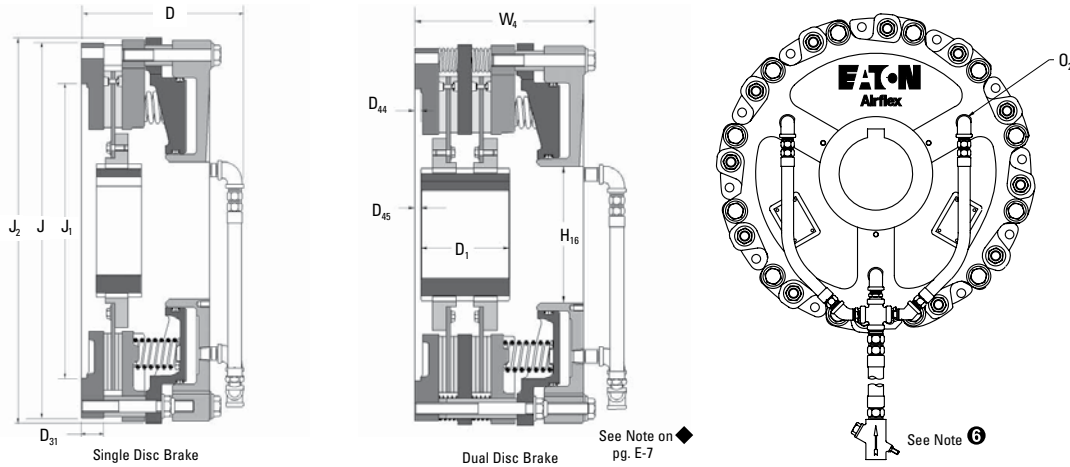

English			lb · in	psi	in ³	in ²	lb · ft ²	lb		rpm
109DBB	146333	415313	7500	60	30	96	0.5	9	115	3000
209DBB	146334	415314	14000	60	30	192	1	18	145	3000
309DBB	146380	416481	19400	60	30	238	1.83	27	135	3000
115DBB	146222	415454	30000	60	75	238	5	35	225	2400
215DBB	146337	415302	57000	60	75	476	10	64	275	2400
120DBB	146299	415900	53500	60	133	334	17	40	385	1850
220DBB	146300	416059	101500	60	133	668	33	67	487	1850
320DBB	146378	416304	149500	60	133	1002	49	213	590	1850
420DBB	146379	416471	180000	60	133	1336	65	102	695	1850
125DBB	146315	416073	115300	60	259	600	47	78	705	1400
225DBB	146327	416074	219000	60	259	1201	93	148	935	1400
325DBB	146370	416223	303000	60	259	1802	139	403	1120	1400
425DBB	146381	416477	392000	60	259	2403	185	280	1250	1400
138DBB	146295	416068	420000	60	612	1322	287	203	1955	950
238DBB	146296	416069	800000	60	612	2644	562	340	2325	950
338DBB	146386	416241	1153000	60	612	3966	837	1087	3280	950
438DBB	146387	416464	1470000	60	612	5288	1112	1424	3850	950

Size	Part Number	Gear Part Number	M ₀ Torque rating	Minimum releasing pressure	▲ Releasing Volume	Friction Area	Disc & Gear		Housing	Maximum speed
							Wk ² J	Weight Mass		
109DBB	146333	415313	847	4,1	0,49	619	0,02	4	52	3000
209DBB	146334	415314	1581	4,1	0,49	1238	0,04	8	66	3000
309DBB	146380	416481	2192	4,1	0,49	1857	0,07	12	36	3000
115DBB	146222	415454	3387	4,1	1,23	1535	0,21	16	102	2400
215DBB	146337	415302	6435	4,1	1,23	3070	0,42	29	125	2400
120DBB	146299	415900	6040	4,1	2,18	2154	0,71	18	175	1850
220DBB	146300	416059	11459	4,1	2,18	4309	1,39	30	221	1850
320DBB	146378	416304	16879	4,1	2,18	6463	2,06	97	277	1850
420DBB	146379	416471	20338	4,1	2,18	8617	2,73	46	315	1850
125DBB	146315	416073	13017	4,1	4,25	3870	1,97	35	320	1400
225DBB	146327	416074	24725	4,1	4,25	7746	3,91	67	424	1400
325DBB	146370	416223	34237	4,1	4,25	11623	5,84	183	508	1400
425DBB	146381	416477	44067	4,1	4,25	15499	7,77	127	567	1400
138DBB	146295	416068	47418	4,1	10,03	8527	12,05	92	887	950
238DBB	146296	416069	90320	4,1	10,03	17054	23,60	154	1055	950
338DBB	146386	416241	130282	4,1	10,03	25581	35,15	493	1488	950
438DBB	146387	416464	166101	4,1	10,03	34108	46,70	646	848	950

SI **n m** **bar** **dm³** **cm²** **kg m²** **kg** **rpm**

Airflex® DBBS Component Parts

Section E

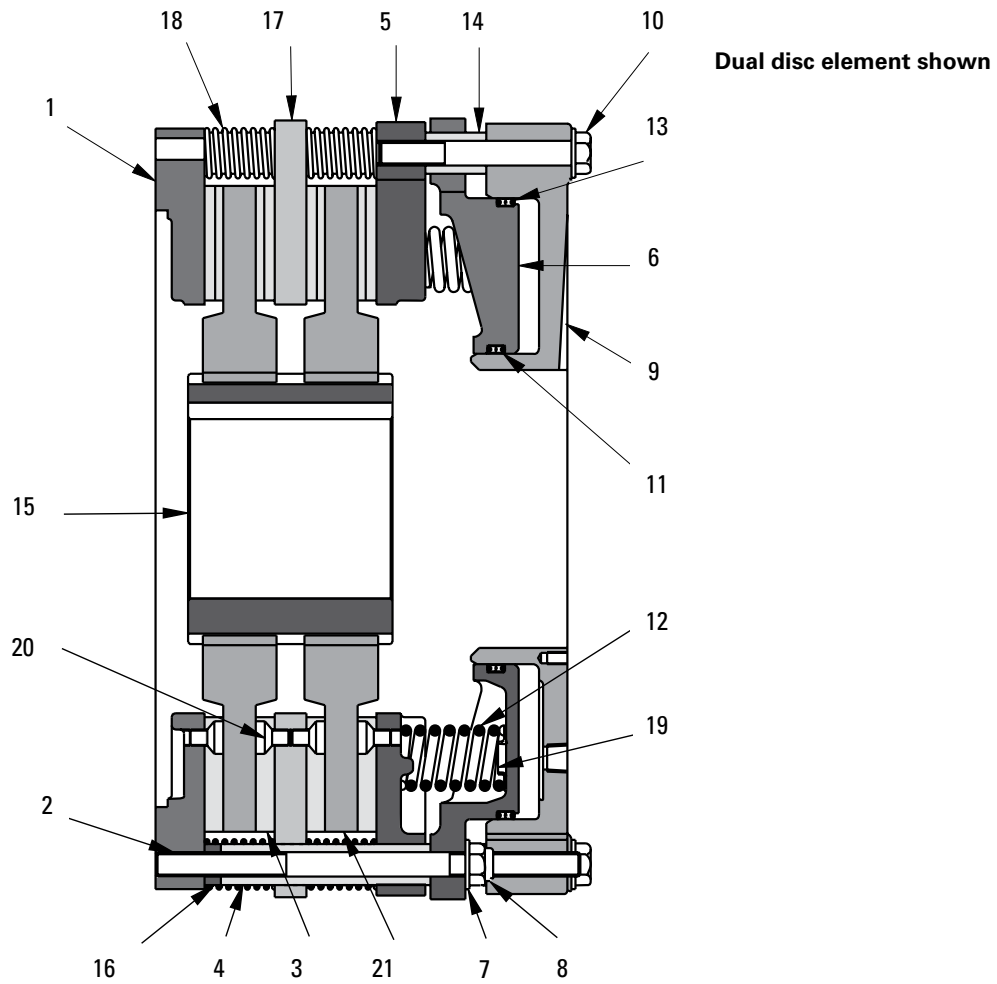

Item Number	Description
1	Mounting Flange
2	Stud
3	Friction Disc
4	Clamp Tube
5	Pressure Plate
6	Spring Housing
7	Flat Washer
8	Lock Nut
9	Cylinder
10	Hex Head Screw
11	Inner Seal
12	Spring
13	Outer Seal
14	Spacer Tube
15	Gear
16	Wear Spacer
17	Reaction Plate
18	Release Spring
19	Spring Retainer
20	Flat Head Screw
21	Disc

Airflex® DBBS Brake Elements

Dimensional and Technical Data

Section E

English	Dimensions in inches			
120DBBS	3.50	5.63	10.30	3.00
220DBBS	4.25	5.69	13.48	6.27
320DBBS	4.88	5.75	16.63	10.31
420DBBS	5.13	5.81	19.81	12.50
125DBBS	4.50	7.00	11.49	3.50
225DBBS	5.50	7.13	14.73	7.00
325DBBS	6.13	7.38	17.96	12.00
425DBBS	6.63	7.31	21.19	15.00
138DBBS	8.50	10.06	15.20	5.00
238DBBS	8.50	10.06	18.97	9.00
338DBBS	9.63	10.06	22.60	13.00
438DBBS	10.38	10.38	26.34	18.00
150DBBS	10.24	15.51	20.43	5.75
250DBBS	12.36	15.51	24.84	10.00
350DBBS	13.90	15.51	29.29	14.49
450DBBS	14.88	15.51	35.24	20.00

Size	Bore Range		D	D ₁
	Min.	Max.		
120DBBS	89	143	262	76
220DBBS	103	145	342	159
320DBBS	124	146	422	262
420DBBS	130	148	503	318
125DBBS	114	177	292	89
225DBBS	140	181	374	178
325DBBS	156	187	456	381
425DBBS	168	186	538	381
138DBBS	216	256	386	127
238DBBS	216	256	482	229
338DBBS	245	256	574	330
438DBBS	264	264	669	457
150DBBS	260	394	519	146
250DBBS	314	394	631	254
350DBBS	353	394	744	368
450DBBS	378	394	895	508

SI	Dimensions in millimeters							
English	Dimensions in inches							
20DBBS	1.50	0.38	1.00	8.50	23.25 [ⓐ]	18.250	23.82	1/2-14
25DBBS	1.75	0.25	1.00	11.50	30.63 [ⓐ]	24.375	30.89	1/2-14
38DBBS	2.45	0.25	1.00	16.50	44.498 [ⓐ]	36.375	45.00	3/4-14
50DBBS	3.50	0.25	2.00	23.00	46.25 [ⓐ]	57.64	1-11	1/2

Size	D ₃₁	D ₄₄	D ₄₅	H ₁₆	J [ⓐ]	J ₁ [ⓐ]	J ₂ [ⓐ]	O ₂ [ⓐ]
20DBBS	38	10	25	216	590.6	463.5	605	1/2-14
25DBBS	44	6	25	292	778.0	619.1	785	1/2-14
38DBBS	62	6	25	419	1135.7	923.9	1143	3/4-14

SI	Dimensions in millimeters							
----	---------------------------	--	--	--	--	--	--	--

Notes:

- ① Brake in disengaged position.
- ⓐ Tolerance +0.000/-0.005 in (+0.00/-0.08 mm)
- ⓑ Tolerance +0.003/-0.000 in (+0.08/-0.00 mm)
- ⓒ Maximum diameter of "as cast" surfaces.
- ⓓ American National Pipe Thread.
- ⓔ Tolerance +.120/- .120 in (+3.00/-3.00 mm)
- * Sizes 325 and 425 have 0.781 (19.8) mounting holes

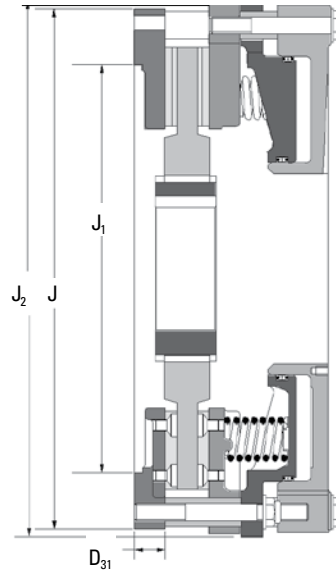

Single Disc element

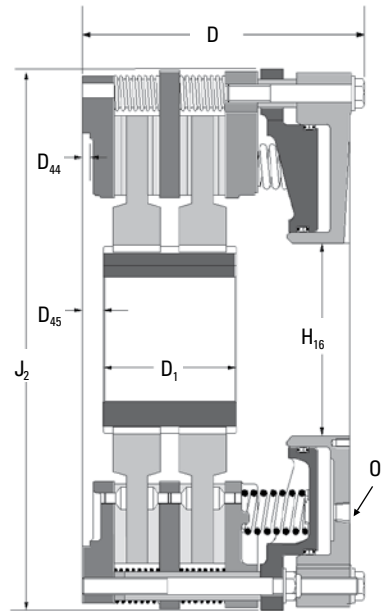

Dual Disc element

Mounting Bolt Circles

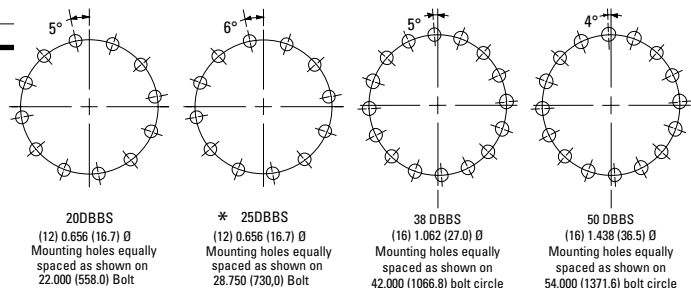

Airflex® DBBS Brake Elements

Dimensional and Technical Data

Section E

English			lb in	Worn Torque Multiplier	psi	in ³	in ²	lb ft ²	lb	rpm	
120DBBS	146323	415900	80,000	—	90	133	346	33	125	400	2200
220DBBS	146322	416059	150,000	—	90	133	692	65	232	550	2200
320DBBS	146373	416471	224,000	—	90	133	1,038	120	357	720	2200
420DBBS	146374	416472	220,000	—	90	133	1,384	159	464	914	2200
125DBBS	146320	416073	173,000	—	90	259	628	89	212	880	1700
225DBBS	146330	416074	325,000	—	90	259	1,255	178	416	1,318	1700
325DBBS	146382	416477	455,000	—	90	259	1,883	309	682	1,585	1700
425DBBS	146383	416470	585,000	—	90	259	2,510	411	854	1,882	1700
138DBBS	146328	416068	630,000	.81	90	612	1,357	553	583	2,125	950
238DBBS	146329	416069	1,200,000	.80	90	612	2,714	1,094	1,100	3,125	950
338DBBS	146384	416414	1,730,000	.80	90	612	4,071	1,709	1,680	4,085	950
438DBBS	146385	416461	2,200,000	.79	90	612	54,28	2,285	2,264	4,975	950
150DBBS	146524	417277	1,798,000	.81	120	1,115	2,111	1,682	1,071	5,872	600
250DBBS	146525	417278	3,284,000	.79	120	1,115	4,222	3,330	1,929	7,196	600
350DBBS	146526	417279	4,555,000	.77	120	1,115	6,333	4,895	2,738	8,685	600
450DBBS	146527	417280	5,578,000	.75	120	1,115	8,444	6,506	3,515	10,092	600

Size ⓐ	ⓑ Part Number	Ⓒ Gear Part Number	Ⓜ, ⓔⓔ Torque Rating	Worn Torque Multiplier	Minimum ⓑ Releasing Pressure	ⓔ Releasing volume	Friction Area	Disc & Gear	Housing	Maximum Speed	
							Wk ² J	Weight Mass			
120DBBS	146323	415900	9.032	—	6,2	2,18	2.232	1,39	56	181	2200
220DBBS	146322	416059	16.935	—	6,2	2,18	4.465	2,74	105	249	2200
320DBBS	146373	416471	25.290	—	6,2	2,18	6.697	5,06	162	327	2200
420DBBS	146374	416472	24.839	—	6,2	2,18	8.930	6,70	211	415	2200
125DBBS	146320	416073	19.532	—	6,2	4,24	4.052	3,75	96	398	1700
225DBBS	146330	416074	36.693	—	6,2	4,24	8.097	7,50	188	596	1700
325DBBS	146382	416477	51.372	—	6,2	4,24	12.149	13,03	310	720	1700
425DBBS	146383	416470	66.049	—	6,2	4,24	16.194	17,34	388	855	1700
138DBBS	146328	416068	71.127	.81	6,2	10,02	8.755	23,30	264	962	950
238DBBS	146329	416069	135.480	.80	6,2	10,02	17.510	46,10	498	1.414	950
338DBBS	146384	416414	195.325	.80	6,2	10,02	26.265	72,10	736	1.856	950
438DBBS	146385	416461	248.391	.79	6,2	10,02	35.020	96,41	1.029	2.261	950
150DBBS	146524	417277	203,164	.81	8,3	18,3	13,619	70,88	486	2,663	600
250DBBS	146525	417278	371,073	.79	8,3	18,3	27,239	140,33	875	3,264	600
350DBBS	146526	417279	514,689	.77	8,3	18,3	40,858	206,28	1,242	3,939	600
450DBBS	146527	417280	630,282	.75	8,3	18,3	54,477	274,16	1,594	4,578	600
SI			N·m		bar	dm ³	cm ²	kg·m ²	kg	rpm	

Notes:

- ① Basic part number only. Does not include gear. Gear must be ordered separately with bore and keyway requirements.
- ② Dynamic torque shown. Static torque approximately 15% greater. Torque values are for new linings. Torque decreases with lining wear. At worn out condition, torque is approximately 0.66 of values shown, unless otherwise noted.
- ③ Torque ratings are for units with a standard complement of springs. Consult factory for torque ratings of units with non-standard spring

configurations.

- ④ Maximum allowable cylinder pressure is 120 psi (8,31 bar).
- ⑤ Absolute volume of releasing cavity.

Airflex® Type DC Element Description

Section E

Type DC elements can be used as either pressure actuated clutches or brakes. They are available in single and multiple disc designs.

Element construction and operation is illustrated in the figure. Pressurizing the cylinder causes the piston to clamp the friction disc assemblies between clamping plates. External springs ensure positive disengagement.

Type DC elements are available in five basic disc sizes with static torque ratings to 2,061,000 lb-in (233,000 N·m). Element sizes are indicated by the number of friction discs and by the disc diameter in inches. For instance, size 225DC has two friction discs 25 inches in diameter.

Features

Favorable torque to size ratio.

DC type elements are physically smaller than most other type clutches and brakes with the same torque capacity.

Low inertia friction disc assembly.

Reduces the overall inertia that must be started or stopped.

Optional split friction discs.

Allows removal of friction discs without disturbing other components of drive system in mid-shaft element arrangement.

Long wearing, self lubricating PolyPak* seals.

Eliminates premature twisting failure and requires no external lubrication.



Where used:

- Power Presses
- Tension Brakes
- Emergency Stop Brakes on Unwind Stands

Airflex® DC Component Parts

Section E

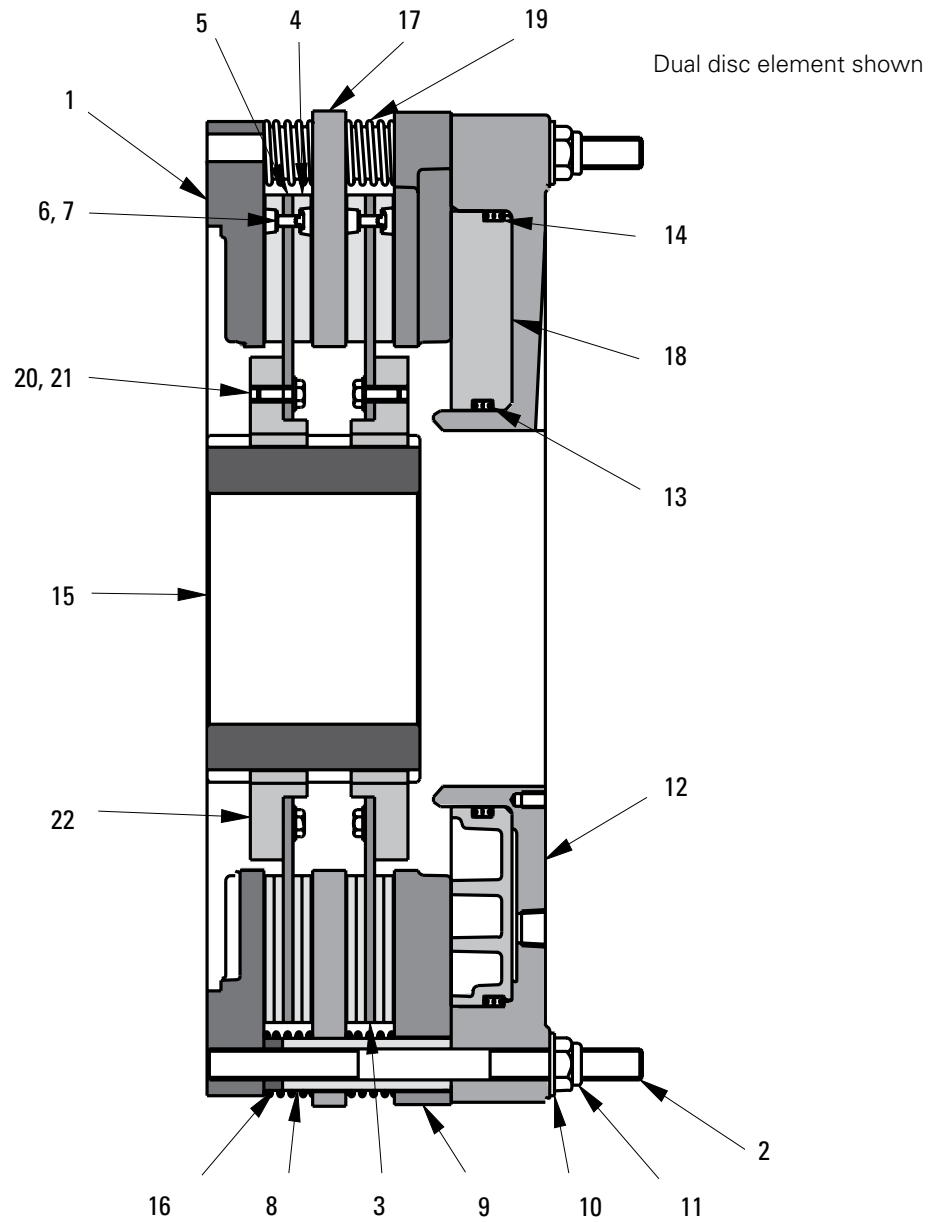

Item Number	Description
1	Mounting Flange
2	Stud
3	Friction Disc Sub-Assembly
4	Friction Disc
5	Friction Disc Core
6	Rivet
7	Washer
8	Clamp Tube
9	Pressure Plate
10	Flat Washer
11	Locknut

Item Number	Description
12	Cylinder
13	Inner Seal
14	Outer Seal
15	Gear
16	Wear Spacer
17	Reaction Plate
18	Piston
19	Release Spring
20	Flat Washer
21	Hex Head Screw
22	Ring Gear

Airflex® Type DC Elements

Technical Data

Section E

English	lb-in @ 75 psi	rpm	in ³	in ²	lb-ft ²	lb				
109DC	10500	3000	1600	4	24	96	8	0.5	60	9
209DC	21000	3000	1600	7	30	192	9.5	1	70	18
115DC	41000	2400	1050	9	60	238	55	5	170	35
215DC	82000	2400	1050	17	70	476	65	10	190	64
120DC	77000	1850	850	27	133	334	82	17	235	77
220DC	154000	1850	850	53	160	668	104	33	297	145
320DC	231000	1850	850	79	187	1002	126	49	359	213
420DC	308000	1850	850	105	214	1336	148	66	421	281
125DC	160000	1400	650	43	216	600	339	47	557	143
225DC	320000	1400	650	86	259	1201	420	93	689	273
325DC	480000	1400	650	129	302	1801	501	140	821	403
425DC	640000	1400	650	172	345	2400	582	186	953	533
138DC	560000	950	450	102	510	1322	2031	287	1568	413
238DC	1120000	950	450	203	612	2644	2139	562	1651	750
338DC	1680000	950	450	304	714	3966	2247	837	1734	1087
438DC	2240000	950	450	405	816	5288	2355	1112	1817	1424

Size	M Torque Rating	Maximum Speed	Engaging Volume		Friction Area	Disc & Gear Housing	Disc & Gear Housing	Disc & Gear Housing	Disc & Gear Housing	
			New	Worn						
			Wk ² J	Weight Mass						
109DC	1190	3000	1600	0,07	0,39	619	0,34	0,02	27	4
209DC	2370	3000	1600	0,11	0,49	1238	0,40	0,04	32	8
115DC	4630	2400	1050	0,15	0,99	1535	2,32	0,21	77	16
215DC	9260	2400	1050	0,28	1,15	3069	2,74	0,42	86	29
120DC	8690	1850	850	0,44	2,18	2154	3,46	0,72	107	35
220DC	17390	1850	850	0,87	2,63	4307	4,38	1,39	135	66
320DC	26080	1850	850	1,30	3,07	6461	5,31	2,06	163	97
420DC	34770	1850	850	1,72	3,52	8614	6,24	2,76	191	127
125DC	18060	1400	650	0,71	3,55	3869	14,29	1,98	253	65
225DC	36130	1400	650	1,41	4,25	7744	17,70	3,92	312	124
325DC	54190	1400	650	2,12	4,96	11619	21,11	5,90	372	183
425DC	72260	1400	650	2,83	5,67	15488	24,53	7,84	432	242
138DC	63220	950	450	1,68	8,38	8524	85,59	12,09	711	187
238DC	126450	950	450	3,33	10,05	17048	90,14	23,68	749	340
338DC	189670	950	450	4,99	11,73	25572	94,69	35,27	786	493
438DC	252900	950	450	6,65	13,41	34097	99,24	46,86	824	646

Notes:

- ① Dynamic torque shown. Static torque 15% greater. Maximum allowable pressure 120 psi (8,3 bar).
- ② Absolute cylinder volume with new or worn friction linings.
- ③ Based upon minimum bore.
- ④ Basic part number only. Gear not included.
- ⑤ Tolerance +0.000/-0.003 in (+0,00/-0,08 mm)

- ⑥ Tolerance +0.003/-0.000 in (+0,08/-0,00 mm)
- ⑦ Maximum diameter of "as cast" surfaces.
- ⑧ American National Pipe Thread
- ⑨ Some high torque applications of three and four disc elements require additional support on the cylinder side of the unit. Contact your local Airflex representative for more details.

Mounting Bolt Circles

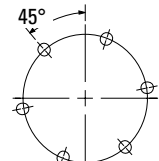

9DC
(6) 0.531 (13.5) Ø Mounting Holes Equally Spaced as Shown on 11.125 (282.5) Bolt Circle

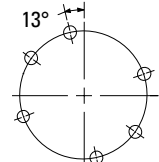

15DC
(6) 0.656 (16.7) Ø Mounting Holes Based on 8 Equally Spaced as Shown on 17.500 (444.5) Bolt Circle

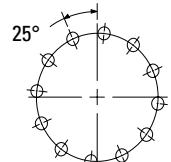

20DC
(12) 0.656 (16.7) Ø Mounting Holes Equally Spaced as Shown on 22.000 (558.8) Bolt Circle

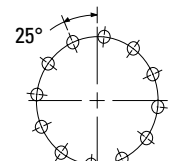

25DC
(12) 0.656 (16.7) Ø Mounting Holes Equally Spaced as Shown on 28.750 (730.3) Bolt Circle

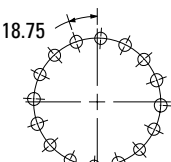

38DC
(16) 1.062 (27.0) Ø Mounting Holes Equally Spaced as Shown on 42.000 (1066.8) Bolt Circle

Airflex® Type DC Elements

Dimensional Data

Section E

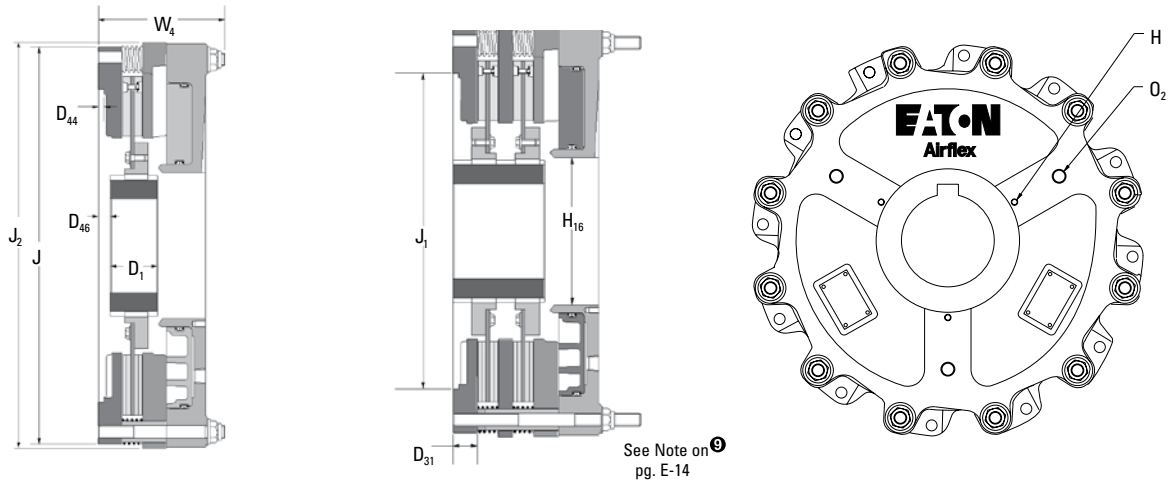

English		Dimensions in inches					
Size	Part #	Part #	Min.	Max.	D ₁	W ₄	D ₄₆
109DC	146239	415313	1.75	2.38	1.75	5.63	0.25
209DC	146240	415510	1.88	2.38	3.25	7.63	0.25
115DC	146225	415454	2.75	3.98	2.88	7.00	0.38
215DC	146226	415454	3.44	3.94	4.38	9.00	0.38
120DC	146301	415900	3.31	5.63	3.00	8.00	0.75
220DC	146317	415959	4.25	5.69	5.63	11.50	0.00
320DC	146366	416304	4.88	5.56	8.25	14.63	0.00
420DC	146390	416472	5.38	5.69	12.50	16.25	0.00
125DC	146316	416073	4.38	7.13	3.50	9.50	0.75
225DC	146355	416074	5.50	7.13	7.00	12.00	0.38
325DC	146354	416623	6.25	6.88	9.31	14.50	0.00
425DC	146389	416477	6.25	6.88	12.00	18.00	0.00
138DC	146307	416068	6.75	10.50	5.00	13.50	1.25
238DC	146336	416069	8.50	10.25	9.00	16.50	0.00
338DC	146360	416241	9.25	9.75	13.00	19.50	0.00
438DC	416388	416461	8.50	10.25	18.00	25.00	0.00

SI		Dimensions in millimeters					
Size	Part #	Part #	Min.	Max.	D ₁	W ₄	D ₄₆
109DC	146239	415313	44	60	44	143	6
209DC	146240	415510	48	60	83	194	6
115DC	146225	415454	70	98	73	178	10
215DC	146226	415454	87	100	111	229	10
120DC	146301	415900	97	143	76	203	19
220DC	146317	415901	108	143	143	292	0
320DC	146366	416304	124	141	210	372	0
420DC	146390	416374	137	145	277	413	0
125DC	146316	416073	111	181	89	241	19
225DC	146355	416074	140	181	178	305	10
325DC	146354	416623	159	175	236	368	0
425DC	146389	416477	159	175	305	457	0
138DC	146307	416068	171	267	127	343	32
238DC	146336	416069	216	260	229	419	0
338DC	146360	416241	235	248	330	495	0
438DC	146388	416461	216	260	457	635	0

English		Dimensions in inches					
Size	D31	D44	H16	H	No.	Size	Bolt Circle
9DC	1.00	0.25	3.25	3	3	1/4-20NC-2	3.50
15DC	1.47	0.38	6.00	3	3	3/8-16NC-2	6.50
20DC	1.50	0.38	8.50	3	3	3/8-16NC-2	9.13
25DC	1.75	0.25	11.50	4	4	3/8-16NC-2	12.25
38DC	2.45	0.25	16.50	4	4	1/2-13NC-2	17.50

SI		Dimensions in millimeters					
Size	D31	D44	H16	H	No.	Size	Bolt Circle
9DC	25	6	83	3	3	1/4-20NC-2	89
15DC	37	10	152	3	3	3/8-16NC-2	165
20DC	38	10	216	3	3	3/8-16NC-2	232
25DC	44	6	292	4	4	3/8-16NC-2	311
38DC	62	6	419	4	4	1/2-13NC-2	445

Notes are on page E - 14

Airflex® FHB Brake Elements

Section E

Overview

Eaton Airflex has introduced a revolutionary new design in disc brake technology called the Floating Housing Brake (FHB). The spring applied (power off), air-cooled disc brake is well suited for applications in Surface Mining, Oilfield and other heavy-duty industrial machinery designs.

The FHB is an air cooled spring applied brake with exceptional friction life and rapid friction replacement capability. It is supplied with long wearing, organic friction material and a rugged solid cast, rotating disc that provides lower inertia than typical caliper brakes.

Features

- Rated for over 430,000 lb-in of torque
- Patented braking concept uses a floating housing instead of a floating rotor
- Multiple brake installation designs exist for industry leading motors
- Fixed hub and rotor design

Benefits

- Ability to quickly change the friction pads reduces down time on dragline from 3 hours to 1 hour
- Reduced maintenance cost with elimination of spline tooth or gear wear
- Longer friction pad wear life due to a full 360° annular disc
- Faster and safer installation with exclusive shaft lock assembly for ease of mounting and removal
- Virtually no wear during free wheeling, allows high product life

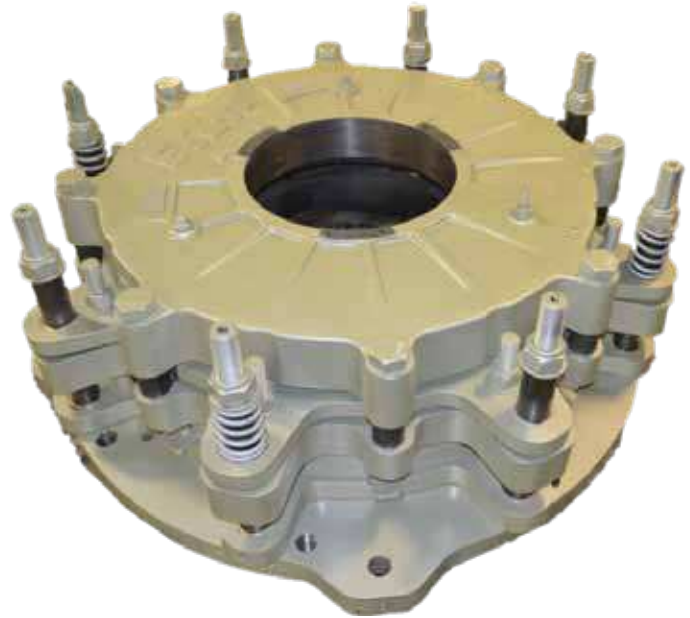

Airflex® FHB Brake Elements

Section E

Technical Introduction

The FHB brake is offered for applications with non-cyclic brake engagement that require higher speed operation or precise balance of the rotating components is required. It uses a solid rotor and stationary friction material to develop equal torque in either direction of rotation. The disc is mounted on the shaft which is to be stopped while the brake assembly is attached to the machine frame. Pressurizing the brake compresses the brake springs and withdraws the clamping force from the brake disc so the shaft can rotate freely. As air pressure is exhausted, the springs force the pressure plate towards the mounting flange and the spring housing which in turn forces the floating plate away from the mounting flange, clamping the disc and the friction pad assembly.

Typical Applications

Draglines	Electric Shovels	Winches
Hoist	Hoist	
Drag	Crowd	
Swing	Swing	
Propel (Walk)	Propel	

Size	No. of Spring Sets	Dynamic Torque*		Max RPM	Length Engaged		Length Released	
		lb-in	N-m		in.	mm.	in.	mm.
138FHB	36	432,900	48,918	950	18.24	463.3	18.48	469.39

*Dynamic torque calculated based on 36 sets of springs, static torque is approximately 15% more. Torque in each application is dependent on number of spring sets.

Airflex® FHB Brake Elements

Section E

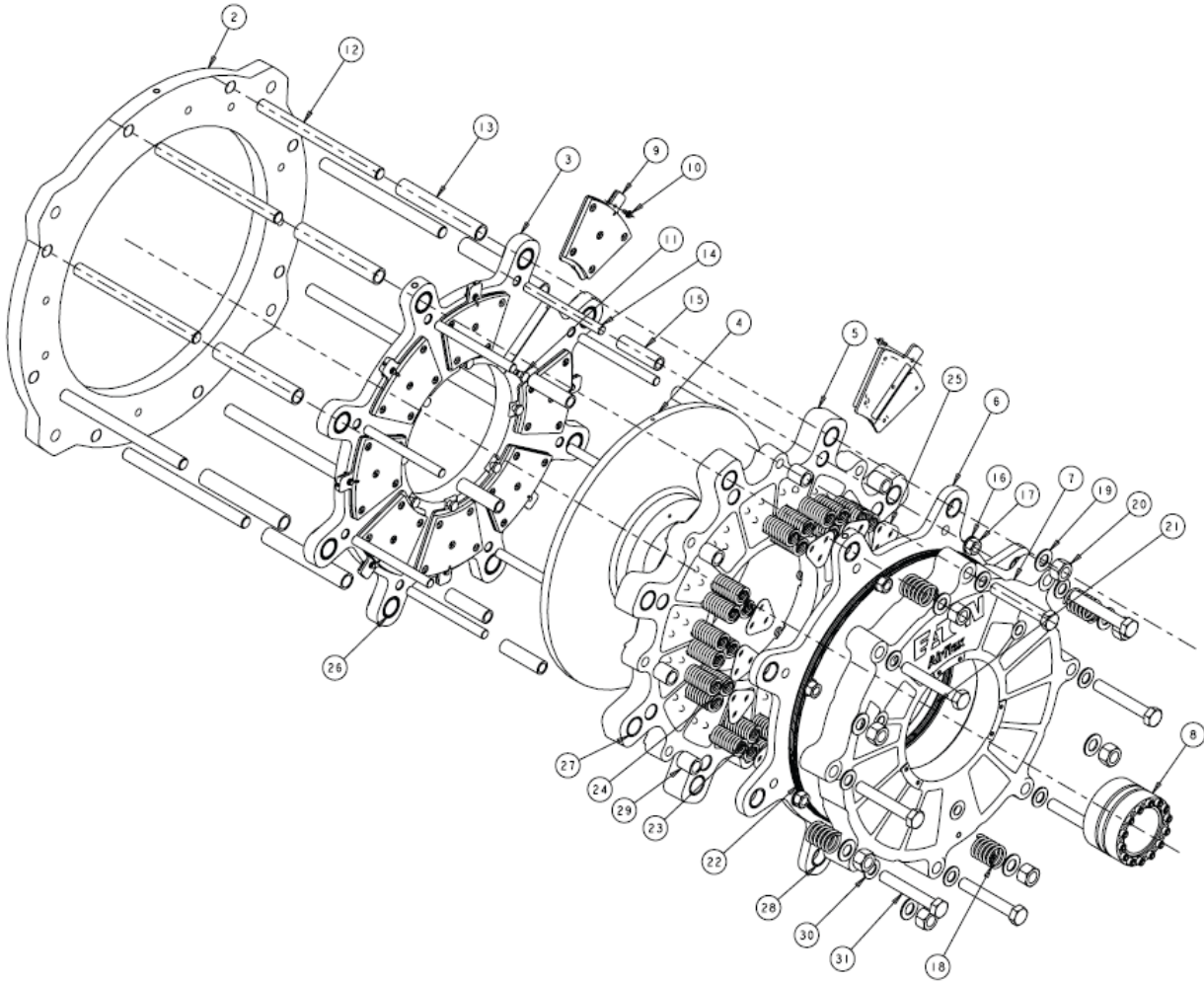

Typical Applications

Item	Qty.	Description	Part Number
*2	1	Mounting Flang	515532
3	1	Floating Plate	515503
*4	1	Disc	515536
5	1	Pressure Plate	515505
6	1	Spring Housing	515507
7	1	Cylinder	515509
*8	1	B-Loc	417385-02
9	16	Friction Linning S/A	308589
10	16	Flanged Bolt	308602
11	16	Metric Shoulder Screw	308593
12	8	Main Stud	308601-01
13	8	Clamp Tube	308586-01
14	8	Support Stud	308592-01
15	8	Spacer	308590-01
16	8	Plain Washer	000067X0063

Typical Applications

Item	Qty.	Description	Part Number
17	8	Nut	000414X0013
18	4	Return Spring	416751-04
19	8	Plain Washer	000067X0065
20	8	Nut	000414X0004
21	2	Lip Seal	000402X0005
22	2	Lip Seal	000402X0006
**23	36	Inner Apply Spring	416751-08
**24	36	Outer Apply Spring	416751-07
25	12	Spring Retainer	415635
26	8	FP Bush	204214-01
27	8	PP Bush	204214-02
28	8	SH Bush	204214-03
29	8	Power Head Spacer	308599-01
30	8	Plain Washer	000067X0064
31	8	Screw	000391X3602

*Part number may vary - depending on application

**Quantity may vary - depending on application requirements

Airflex® FHB Brake Elements

138FHB Specifications and Dimensions Illustrated

Section E

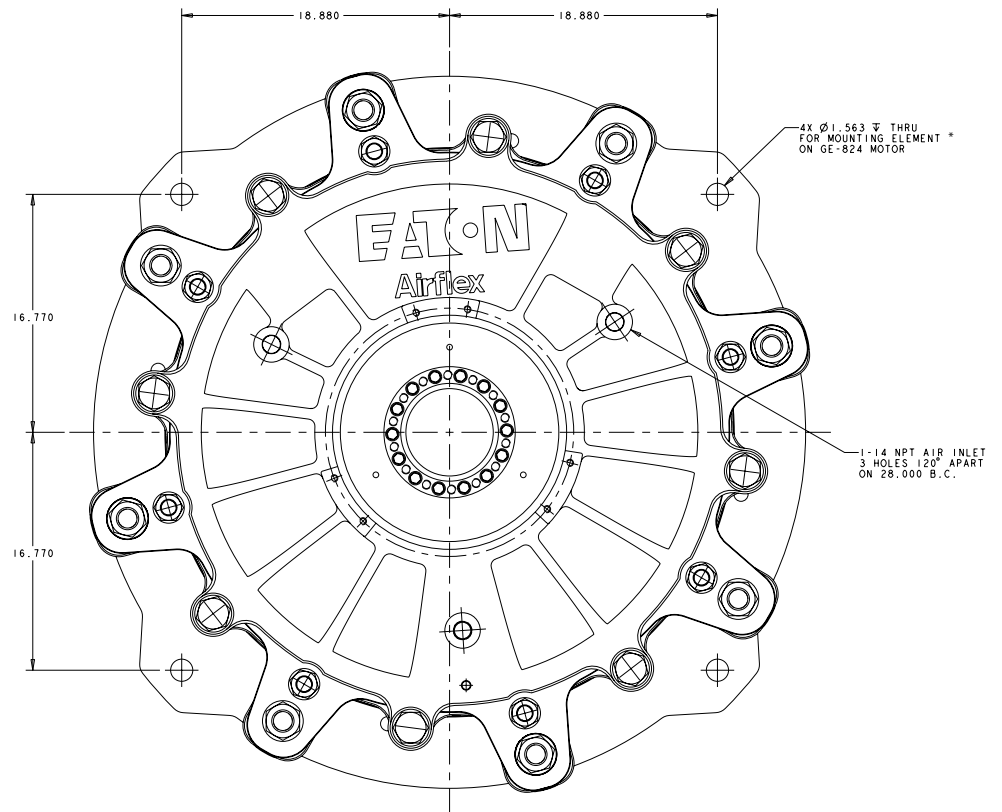
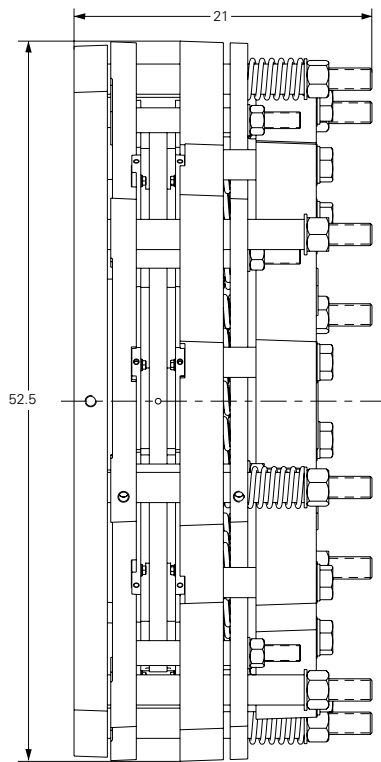

* Consult factory for alternate mounting options.

Airflex® Brake Selection Procedure

Section E

Torque and Thermal Capacities

General

Technical Section Y of the catalog contains useful information pertaining to the selection, mounting, alignment and control of clutches and brakes in general. Formulas, symbols and units are also identified. It is recommended that Section Y be reviewed before attempting to size a specific product for an application.

Torque

DBA and DBB Brakes

The torque ratings are dependent upon spring force and quantity, not a pressurizing medium. However, a pressurizing medium is required to compress the springs to release the brake. Minimum releasing pressures, as well as the maximum pressures which the piston and cylinder can withstand, are given on the catalog pages.

Type DBA and DBB brakes are disc type and develop equal torque in both directions of rotation. Several springs are used in their design. If brake size is determined by thermal requirements rather than torque requirements, brake torque can be reduced by spring removal.

For spring applied brakes, torque will decrease with lining wear, due to the longer piston travel required for engagement. Single disc DBA and DBB brakes have no provision for adjustment. Multiple disc brakes have a provision for adjustment after a given amount of lining wear. Therefore, DBA and DBB brake torque with worn linings must be considered in the selection process.

DC Elements

DC element dynamic torque ratings M_r are based on an effective pressure p_r of 75 psi (5,2 bar). Maximum allowable operating pressure is 120 psi (8,3 bar). Torque ratings must be adjusted for operating pressure p_o and parasitic loss p_p .

The elements have an inherent parasitic pressure p_p , required to cause friction disc engagement, which represents the pressure to overcome internal sliding friction and to compress disc releasing springs.

No. of Friction Discs	Pressure p_r	
	psi	bar
1	3	0,21
2	4	0,28
3	5	0,34
4	6	0,41

Element torque is calculated from:

$$M_e = \frac{p_o - p_p}{p_r} \cdot M_r$$

Cyclic and Non-Cyclic Thermal Capacity

Brake types DBAV and DBB were designed for cyclic stopping applications. They are capable of a maximum thermal capacity P_c of 0.012 HP/in².

Non-cyclic thermal capacity is determined by the element's friction area, drum or disc mass, material heat capacity and thermal conductivity. The properties of our standard elements result in the limits indicated in the Non-Cyclic Energy Capacity Graph. An explanation on the use of this graph follows.

The thermal energy calculated for the load is adjusted to include the energy associated with accelerating or decelerating the components of the tentative clutch and/or brake selection. The adjusted thermal energy W_t is divided by the element's friction area A . Next, the average power loading P_{ave} is calculated from:

$$P_{ave} = \frac{W_t}{A}$$

The point ($W_t/A, P_{ave}$) is plotted on the graph. If the point falls below the appropriate product limit line, the selection will handle the load. If it does not, an element having a greater friction area is required.

Airflex® Selection Procedure

Section E

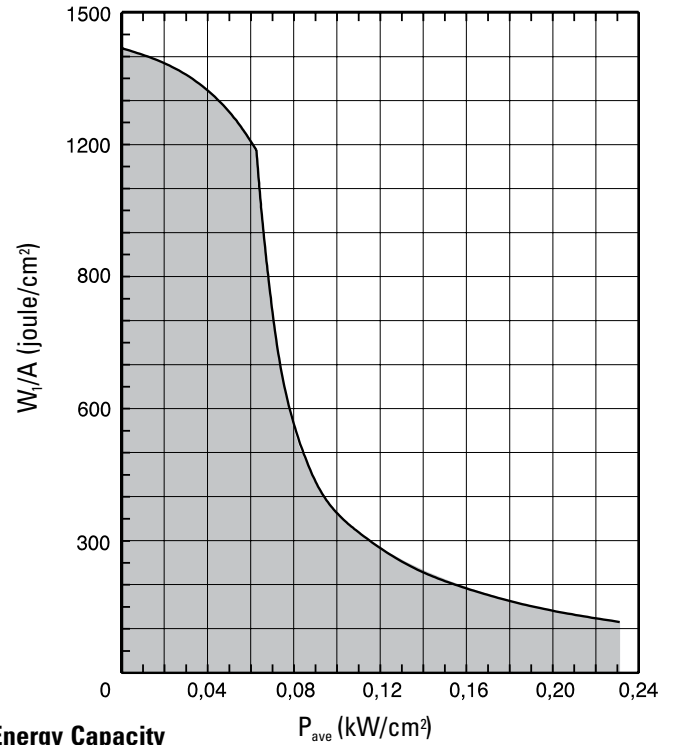
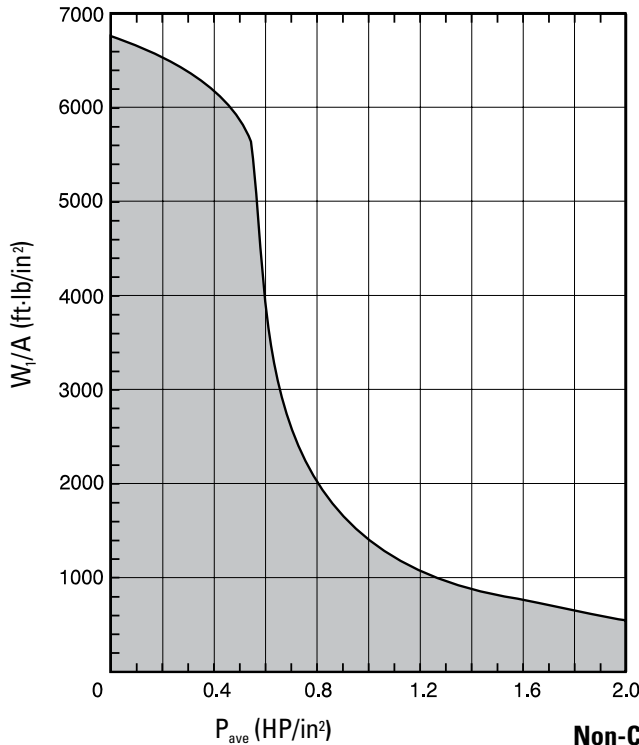

Non-Cyclic Energy Capacity

Example

A cyclic stopping brake is required for use on a power press operating under the following conditions. Determine the brake size and allowable cyclic rate.

Brake shaft speed: 300 rpm

Stopping angle at crankshaft: 15°

Inertia referred to brake shaft: 750 lb·ft²

Press stroke: 10 in

Ram and die weight: 2500 lb

Reduction between brake shaft and crankshaft: 10:1

Stopping angle at brake shaft $\theta_d = 15^\circ \cdot 10 = 150^\circ$

$$t_d = \frac{\theta d}{3 \cdot n} = \frac{150^\circ}{3 \cdot 300} = 0.17 \text{ sec.}$$

$$M_b = \frac{Wk^2 \cdot n}{25.58 \cdot t_d} = \frac{750 \cdot 300}{25.58 \cdot 0.17}$$

$$= 51,700 \text{ lb-in}$$

Reverse brake torque required =

0.5-stroke-weight/reduction

$$= 0.5 \cdot 10 \cdot 2500 / 10$$

$$= 1250 \text{ lb-in}$$

From required torques, select 215DBB

Lining area = 476 in²

Disc and gear $WK^2 = 10 \text{ lb-ft}^2$

Total $WK^2 = 750 + 10 = 760 \text{ lb-ft}^2$

$$W = \frac{Wk^2 \cdot n^2}{5873} = \frac{760 \cdot 300^2}{5873}$$

$$= 11650 \text{ ft-lb}$$

$$P_c = \frac{W \cdot \text{cpm}}{33000}$$

$$\text{cpm} = \frac{P_c \cdot 33000}{W}$$

$$= \frac{0.012 \cdot 476 \cdot 33000}{11650}$$

$$= 16$$